

HP 70138A MMS VECTOR VOLTMETER

Installation and Verification Manual

SERIAL NUMBERS

This manual applies directly to HP 70138A Vector Voltmeters with serial numbers prefixed 2914U.

NOTE

Use this manual only with instruments that have a "U" in their serial-number prefix.

First Edition

Copyright ©HEWLETT-PACKARD LIMITED
SOUTH QUEENSFERRY, WEST LoTHIAN, SCOTLAND EH30 9TG

HP 70138A Manual Set HP Part Number: 70138-90007

Installation and Verification Manual HP Part Number: 70138-90000

Microfiche Installation and Verification Manual HP Part Number: 70138-90001

Printed in U.K. : April 1989



CERTIFICATION

Hewlett-Packard Company certifies that this product met its published specifications at the time of shipment from the factory. Hewlett-Packard further certifies that its calibration measurements are traceable to the United States National Bureau of Standards, to the extent allowed by the Bureau's calibration facility, and to the calibration facilities of other International Standards Organization members.

WARRANTY

This Hewlett-Packard instrument product is warranted against defects in material and workmanship for a period of one year from date of shipment. During the warranty period, Hewlett-Packard Company will at its option, either repair or replace products which prove to be defective.

For warranty service or repair, this product must be returned to a service facility designated by HP. Buyer shall prepay shipping charges to HP and HP shall pay shipping charges to return the product to the Buyer. However, Buyer shall pay all shipping charges, duties, and taxes for products returned to HP from another country.

HP warrants that its software and firmware designated by HP for use with an instrument will execute its programming instructions when properly installed on that instrument. HP does not warrant that the operation of the instrument, or software, or firmware will be uninterrupted or error free.

LIMITATION OF WARRANTY

The foregoing warranty shall not apply to defects resulting from improper or inadequate maintenance by Buyer, Buyer-supplied software or interfacing, unauthorized modification or misuse, operation outside of the environmental specifications for the product, or improper site preparation or maintenance.

NO OTHER WARRANTY IS EXPRESSED OR IMPLIED. HP SPECIFICALLY DISCLAIMS THE IMPLIED WARRANTIES OF MERCHANTABILITY AND FITNESS FOR A PARTICULAR PURPOSE.

EXCLUSIVE REMEDIES

THE REMEDIES PROVIDED HEREIN ARE BUYER'S SOLE AND EXCLUSIVE REMEDIES. HP SHALL NOT BE LIABLE FOR ANY DIRECT, INDIRECT, SPECIAL, INCIDENTAL, OR CONSEQUENTIAL DAMAGES, WHETHER BASED ON CONTRACT, TORT, OR ANY OTHER LEGAL THEORY.

ASSISTANCE

Product maintenance agreements and other customer assistance agreements are available for Hewlett-Packard products.

For any assistance, contact your nearest Hewlett-Packard Sales and Service Office. Addresses are provided in this manual.

SAFETY CONSIDERATIONS

This product and related documentation must be reviewed for familiarization with safety markings and instructions before operation.

The MMS product is a Safety Class 1 instrument provided with a protective earth terminal.

Before Applying Power

Verify that the MMS product is set to match the available line voltage and the correct fuse is installed.

Safety Earth Ground

An uninterruptable safety earth ground must be provided from the main power source to the product wiring terminals, power cord, or supplied power cord set.

WARNING

Any interruption of the protective (grounding) conductor (inside or outside the MMS product) or disconnecting the protective earth terminal will cause a potential shock hazard that could result in personal injury. (Grounding one conductor of a two conductor outlet is not sufficient protection.) In addition, verify that a common ground exists between the unit under test and this instrument prior to energizing either unit.

Whenever it is likely that protection has been impaired, the MMS product must be made inoperative and secured against any unintended operation.

If the MMS product is to be energized via an autotransformer (for voltage reduction) make sure the common terminal is connected to neutral (that is, the grounded side of the mains supply).

Servicing instructions are for use by service-trained personnel only. To avoid dangerous electrical shock, do not perform any servicing unless qualified to do so.

Adjustments described in this manual are performed with power supplied

to the instrument while protective covers are removed. Energy available at many points may, if contacted, result in personal injury.

Capacitors inside the instrument may still be charged even if the instrument has been disconnected from its source of supply.

For continued protection against fire hazard, replace the line fuse(s) only with 250V fuse(s) of the same current rating and type (for example, normal blow, time delay, etc). Do not use repaired fuses or short circuited fuse holders.

Safety Symbols



Instruction manual symbol: The product will be marked with this symbol when it is necessary for the user to refer to the manual.



Indicates hazardous voltages.



Indicates earth (ground) terminal.

WARNING

The **WARNING** sign denotes a hazard. It calls attention to a procedure, practice, or the like, which, if not correctly performed or adhered to, could result in personal injury. Do not proceed beyond a **WARNING** sign until the indicated conditions are fully understood and met.

CAUTION

The **CAUTION** sign denotes a hazard. It calls attention to an operating procedure, practice, or the like, which, if not correctly performed or adhered to, could result in damage to or destruction of part or all of the product. Do not proceed beyond a **CAUTION** sign until the indicated conditions are fully understood and met.

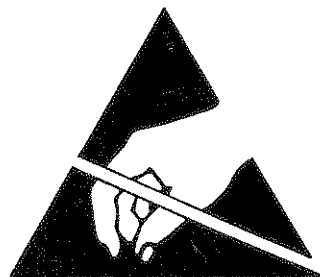

**ATTENTION
Static Sensitive
Devices**

This instrument was constructed in an ESD (electro-static discharge) protected environment. This is because most of the semi-conductor devices used in this instrument are susceptible to damage by static discharge.

Depending on the magnitude of the charge, device substrates can be punctured or destroyed by contact or mere proximity of a static charge. The results can cause degradation of device performance, early failure, or immediate destruction.

These charges are generated in numerous ways such as simple contact, separation of materials, and normal motions of persons working with static sensitive devices.

When handling or servicing equipment containing static sensitive devices, adequate precautions must be taken to prevent device damage or destruction.

Only those who are thoroughly familiar with industry accepted techniques for handling static sensitive devices should attempt to service circuitry with these devices.

In all instances, measures must be taken to prevent static charge build-up on work surfaces and persons handling the devices.



Herstellerbescheinigung

Hiermit wird bescheinigt, daß das Gerät/System

HP 70138A

in Übereinstimmung mit den Bestimmungen von Postverfügung 1046/84 funkentstört ist.

Der Deutschen Bundespost wurde das Inverkehrbringen dieses Gerätes/Systems angezeigt und die Berechtigung zur Überprüfung der Serie auf Einhaltung der Bestimmungen eingeräumt.

Zusatzinformation für Meß- und Testgeräte

Werden Meß- und Testgeräte mit ungeschirmten Kabeln und/oder in offenen Meßaufbauten verwendet, so ist vom Betreiber sicherzustellen, daß die Funk-Entstörbestimmungen unter Betriebsbedingungen an seiner Grundstücksgrenze eingehalten werden.

Manufacturer's declaration

This is to certify that this product HP 70138A meets the radio frequency interference requirements of directive 1046/84. The German Bundespost has been notified that this equipment was put into circulation and was granted the right to check the product type for compliance with these requirements.

Note: If test and measurement equipment is operated with unshielded cables and/or used for measurement on open set-ups, the user must insure that under these operating conditions, the radio frequency interference limits are met at the border of his premises.

CONTENTS

1.	GENERAL INFORMATION	
	Introduction	1-1
	Manual Organization	1-1
	Safety Considerations	1-1
	Modules Covered by Manual	1-2
	Serial Numbers	1-2
	Manual Updating Supplement	1-2
	Customer Label Protection	1-2
	System Calibration	1-3
	Electrostatic Discharge Information	1-3
	Test Equipment	1-4
	ESD Accessories	1-4
	Sales and Service Offices	1-5
	Initial Inspection	1-5
	Module Description	1-6
	Options	1-6
	Accessories	1-6
	Returning Instruments for Service	1-6
	Packaging	1-6
	Instrument Shipping Preparation Procedure	1-8
2.	INSTALLATION	
	Introduction	2-1
	Initial Inspection	2-2
	Installation Preparation	2-2
	Installation Checklist	2-2
	Addressing the Module	2-2
	Determining the HP-MSIB Address	2-3
	Functional Terms	2-4
	Structural Terms	2-4
	Address Map Protocol	2-4
	Address Matrix	2-5
	Display-Response Area	2-5
	HP-IB Access	2-6
	Master and Slave Elements	2-6
	Sub-Masters	2-7
	Slave Area	2-7
	Slave Area Boundaries	2-8
	Independent Elements	2-8

Addressing Order Requirements	2-8
Address Switches	2-8
Setting the HP-MSIB Address Switches	2-10
Installing the Module in the Mainframe	2-11
Initial Power-on	2-12
3. SPECIFICATIONS	
Introduction	3-1
Specifications	3-1
4. VERIFICATION	
Introduction	4-1
Equipment Required	4-1
Displaying the HP 70138A Readings	4-3
Power-on Self Test	4-3
5. TROUBLESHOOTING	
Introduction	5-1
Troubleshooting Tools	5-1
Status Indicators	5-1
Error Message Reporting	5-3
HP 70138A Vector Voltmeter Self-Test	5-6
Exchanging the HP 70138A	5-7
Removing the Module from the Mainframe	5-7
Removing the Module Front Frame	5-7
Replacing the Module Front Frame	5-8
Reinserting the Module in the Mainframe	5-8
Instrument Serial Number	5-8
Diagnostic Procedures	5-9
Categorizing Failures	5-9
Troubleshooting from the Front Panel	5-10
Troubleshooting the HP 70138A	5-11
Troubleshooting over HP-IB	5-13
Troubleshooting Catastrophic Failures	5-13
Using the HP-MSIB Troubleshooting Utility	5-17
Error Messages	5-23
Module Self-Test	5-23
Status ACT	5-23
Status ERR	5-24
Hardware Warning Errors	5-24

GENERAL INFORMATION

INTRODUCTION

The HP 70138A Installation and Verification Manual contains information needed to install and verify the HP 70138A Vector Voltmeter into an HP 70000 Modular Measurement System. For information on installing and verifying other MMS system components, refer to the appropriate installation and verification manual.

MANUAL ORGANIZATION

This manual contains the following five chapters:

Section 1, General Information, describes the module and its accessories, gives electrostatic discharge and packaging information, and lists Hewlett-Packard Sales and Service Offices.

Section 2, Installation, provides information for configuring and installing the module in an HP 70000 Modular Measurement System.

Section 3, Specifications, lists module specifications and characteristics.

Section 4, Verification, contains tests required to verify module specifications.

Section 5, Troubleshooting, explains the probable cause(s) indicated by front-panel status/error LEDs, and lists the error codes that can be produced or caused by the HP 70138A Vector Voltmeter.

This manual uses the following conventions:

[KEY] A boxed, uppercase key-name in this typeface represents a key physically located on the display.

[SOFTKEY] A boxed word written in this typeface indicates a "softkey," a key whose label is determined by the instrument's firmware.

CRT Text Text printed in this typeface indicates text displayed on the CRT.

SAFETY CONSIDERATIONS

Before operating this module, familiarize yourself with any safety markings on the module and the safety instructions in this manual. This module has been manufactured and tested according to international safety standards. The cautions and warnings in this manual must be followed to ensure the safe operation of the module and protection of the personnel. Refer to the summary of safety considerations at the front of this manual.

MODULES COVERED BY MANUAL

The contents of this manual apply to HP 70138A modules with the serial number prefix(es) listed under "Serial Numbers" on the title page.

SERIAL NUMBERS

Attached to the lower part of the front frame of the module is a serial-number label. The serial number is in the form 0000U00000. The first four digits and the letter are the serial number prefix. The last five digits are the suffix. The prefix is the same for identical instruments; it changes only when a configuration change is made to the instrument. The suffix, however, is assigned sequentially and is different for each instrument. The contents of the manual apply directly to instruments having the serial number prefix(es) listed under SERIAL NUMBERS on the title page.

MANUAL UPDATING SUPPLEMENT

A module manufactured after this manual was printed may have a serial-number prefix other than that listed under "Serial Numbers" on the manual title page. A higher serial-number prefix than stated on the title page indicates that changes have been made to the module since the manual was printed.

Any changes that affect information in this manual are documented in the Manual Updating Supplement for this manual. The Manual Updating Supplement may also contain information for correcting errors in the manual. To keep the manual as current and accurate as possible, periodically request the latest Manual Updating Supplement for this manual from your nearest Hewlett-Packard Sales and Service Office.

CUSTOMER LABEL PROTECTION

The location of calibration and customer asset identification labels is important, since the modules comprising the HP 70000 Modular Measurement System are core-serviceable or replaceable.

Customer labels for calibration and asset identification should be placed on the front panel of a module.

The calibration label indicates that the system has met certain specifications. The HP 70138A must pass all of its Systems Performance Tests before the customer may qualify the system for a calibration label. The customer's own label may be applied, or an HP service office may perform the calibration routine and apply an HP calibration label to the front panel of a module.

Asset labeling is used to identify ownership of a module. Customers should apply their own asset labels to front panels of modules in their systems.

CAUTION

Do not place labels on the inside of the mainframe front-access door. Damage may result to labels due to opening and closing the mainframe front-access door.

SYSTEM CALIBRATION CERTIFICATION

To qualify for calibration certification, **allow the instrument to WARM UP for at least ONE HOUR**, then perform the HP 70138A Systems Performance Tests documented in this manual. If all tests pass, a certification label may be applied to the front panel of the system.

ELECTROSTATIC DISCHARGE INFORMATION

Electrostatic discharge (ESD) can damage or destroy electronic components. All work on electronic assemblies should be performed at a static-safe work station.

Figure 1-1 shows an example of a static-safe work station using two types of ESD protection:

- a) conductive table-mat and wrist-strap combination,
- b) conductive table-mat and heel-strap combination.

The two types must be used together to ensure adequate ESD protection.

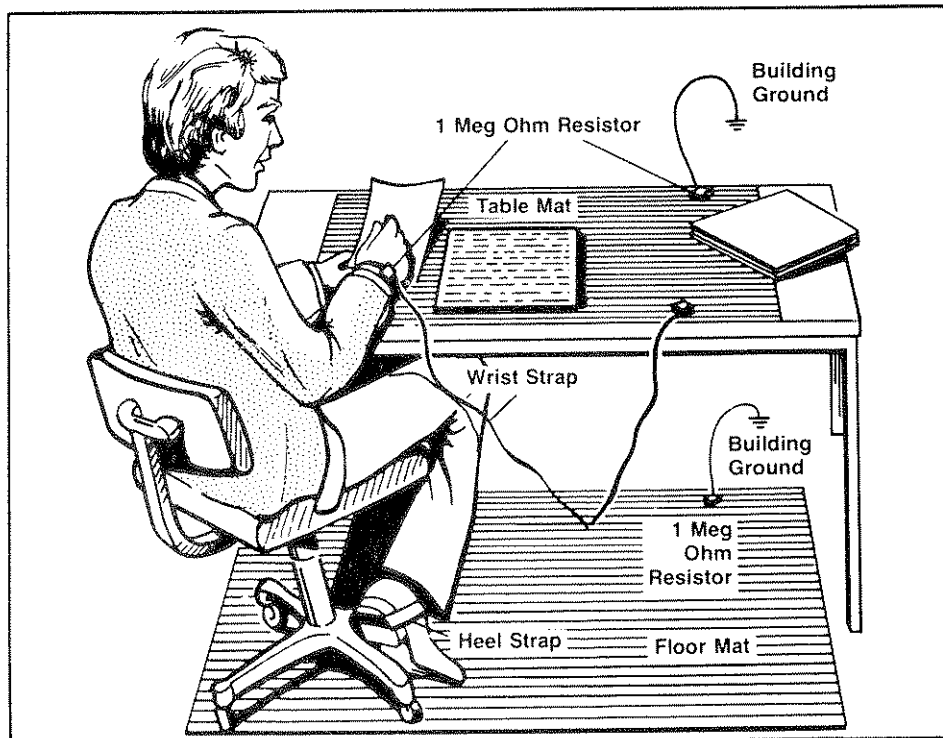

Figure 1-1. Static-Safe Work Station

TEST EQUIPMENT

Before connecting any coaxial cable to an instrument connector for the first time each day, momentarily short the center and outer conductors of the cable together.

Personnel should be grounded with a resistor-isolated wrist-strap before touching the center pin of any connector and before removing any assembly from the instrument.

Be sure that all instruments are properly earth-grounded to prevent build-up of static charge.

ESD Accessories

The following static-safe accessories may be ordered from a Hewlett-Packard sales or service office:

HP Part Number 9300-0797
3M static control mat 0.6m x 1.2m (2ft x 4ft)
4.6cm (15ft.) ground wire
(The wrist-strap and wrist-strap cord are not included. They must be ordered separately.)

HP Part Number 9300-0980
Wrist strap cord 1.5m (5ft)

HP Part Number 9300-0985
Wrist strap (large)

HP Part Number 9300-0986
Wrist strap (small)

HP Part Number 9300-1169
ESD heel strap (reusable 6 to 12 months)

HP Part Number 9300-0793
Shoe ground strap (one time use only)

The ESD accessories listed below may be ordered from:

Hewlett-Packard Company
Computer Supplies Operations
1320 Kifer Road
Sunnyvale, California 94086
Phone: (408) 738-8858

HP Part Number 92175A
Black, hard surface, static control mat, 1.2m x 1.5m (4ft x 5ft)

HP Part Number 92175B
Brown, soft-surface, static control mat, 2.4m x 1.2m (8ft x 4ft)

HP Part Number 92175C
Small, black, hard surface, static control mat, 1.2m x 0.9m (4ft x 3ft)

HP Part Number 92175T
Tabletop static control mat, 58cm x 76cm (23in x 30in)

HP Part Number 92176A
Natural color anti-static carpet, 1.8m x 1.2m (6ft x 4ft)

HP Part Number 92176C
Russet color anti-static carpet, 1.8m x 1.2m (6ft x 4ft)

HP Part Number 92176B
Natural color anti-static carpet, 2.4m x 1.2m (8ft x 4ft)

HP Part Number 92176D
Russet color anti-static carpet, 2.4m x 1.2m (8ft x 4ft)

SALES AND SERVICE OFFICES

Hewlett-Packard has sales and service offices around the world providing complete support for the HP 70138A Vector Voltmeter module. To obtain servicing information or to order replacement parts, contact the nearest Hewlett-Packard Sales and Service Office listed on the inside of the rear cover of this manual. In any correspondence, refer to the module by its model number and any pertinent assembly part numbers.

INITIAL INSPECTION

Inspect the shipping container for damage. If the container or the cushioning material is damaged, check the contents both mechanically and electrically. Run the Operation Verification to check the electrical performance. Instructions for running the Operation Verification software are contained in the Verification section of this manual.

If the instrument appears damaged or is defective, contact the nearest Hewlett-Packard service office. Hewlett-Packard will arrange for repair or replacement of the equipment without waiting for a claim settlement. Retain the shipping materials for the carrier to inspect.

Keep undamaged shipping materials for future shipment or storage of the instrument. The original HP shipping materials, or the equivalent are required for reshipment of instruments. Using substandard packaging can result in instrument damage. Refer to Packaging in this section for detailed packaging information and requirements.

MODULE DESCRIPTION

The HP 70138A Vector Voltmeter is a 2/8-width MMS module, dual-channel, autoranging receiver which measures the voltages of two CW signals of the same frequency and the phase differences between them. The measurements can be of a single channel or the ratio between the two channels, and results can be displayed as voltage or power (in linear or log units), normalized magnitude and phase angle, or real and imaginary components. In addition, the HP 70138A has built-in procedures for simple network analysis. The HP 70138A has two configurations - the first providing two high impedance probe inputs with a frequency range from 100kHz to 1GHz, and the second providing two 50ohm type-N connector inputs with a frequency range of 300kHz to 2GHz. The configuration can be changed by replacing the instrument's input module.

OPTIONS

Option 050 - Replaces the standard HP 85081A 100kHz to 1GHz Input Module with the HP 85082A 300kHz to 2GHz Input Module.

Option 100 - Deletes Input Module. (Requires separate purchase of Input Module for HP 70138A to operate.)

ACCESSORIES

The HP 70138A Vector Voltmeter may be ordered separately or as part of a preconfigured HP 70000 Modular Measurement System. No system cabling or accessories are required for installation into a system. Measurement accessories may be supplied depending upon the Input Module. For details, refer to the appropriate Input Module supplement.

RETURNING INSTRUMENTS FOR SERVICE

If a module is being returned to Hewlett-Packard for servicing, fill in and attach a blue service tag. Service tags are supplied at the end of this manual. Please be as specific as possible about the nature of the problem. Include copies of error messages, data related to module performance, type of system, etc., along with the module being returned.

PACKAGING

The original shipping containers and materials, or the equivalent, should be used for reshipment of the module. If the original materials were not retained, identical packaging materials are available through any Hewlett-Packard office. Figure 1-2 illustrates the factory packaging materials. When ordering packaging material to ship modules, it is necessary to order the proper number of foam inserts/pads.

A 2/8-width module requires two foam pads. Note: this only applies when shipping an HP 70138A minus the input module.

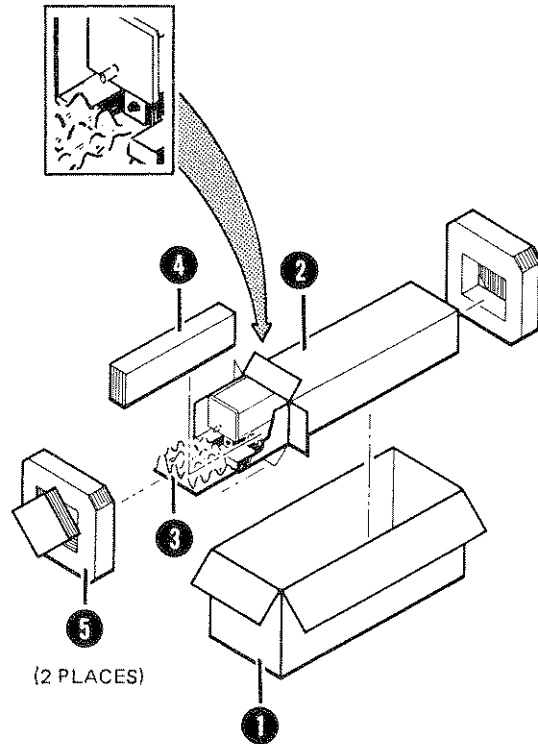

ITEM	QTY	HP PART NO.	DESCRIPTION
1	1	9211-5118	CARTON - OUTER
2	1	9211-5119	CARTON - INNER
3	1	5180-2369	CARTON - SLIDER
4	1	4280-0493	FOAM INSERT
5	2	5180-2370	FOAM PADS

Figure 1-2. Packaging Materials for Modules

CAUTION

Instrument damage can result from using packaging materials other than those specified. Never use styrene pellets as packaging material. They do not adequately cushion the instrument or prevent it from shifting in the carton. They also cause instrument damage by generating static electricity.

Instrument Shipping Preparation Procedure

Fill out a blue repair card (located at the end of this manual) and attach it to the instrument. Include any error messages or specific performance data related to the problem. If a blue repair tag is not available, the following information should be noted and sent with the instrument.

Type of service required.

Description of the problem.

Whether problem is constant or intermittent.

Name and phone number of technical contact person.

Return address.

Model number of returned instrument.

Full serial number of returned instrument.

List of any accessories returned with instrument.

Pack the instrument in the appropriate packaging materials. (See Figure 1-2.) Original shipping materials or the equivalent should be used. If the original or equivalent materials cannot be obtained, instruments can be packaged for shipment using the following instructions.

CAUTION

Inappropriate packaging of instruments may result in damage to the instrument during transit.

Wrap the instrument in anti-static plastic to reduce the possibility of damage caused by ESD.

Use a double-walled, corrugated cardboard carton of 159 kg (350 lb) test strength.

The carton must be large enough to allow three to four inches on all sides of the instrument for packing material and strong enough to accommodate the weight of the instrument.

Surround the equipment with three to four inches of packing material, to protect the instrument and prevent it from moving in the carton.

If packing foam is not available, the best alternative is S.D.-240 Air Cap from Sealed Air Corporation (Commerce, California 90001). Air Cap looks like a plastic sheet filled with air bubbles.

Use the pink (anti-static) Air Cap to reduce static electricity.

Wrapping the instrument several times in this material will protect the instrument and prevent it from moving in the carton.

Seal the carton with strong nylon adhesive tape.

Mark the carton 'FRAGILE, HANDLE WITH CARE'.

Retain copies of all shipping papers.



INSTALLATION

INTRODUCTION

This section contains information needed to install the HP 70138A Vector Voltmeter into an HP 70000 Series mainframe.

For more detailed information about HP 70000 Modular Measurement System configuration, cabling, and HP-MSIB (Hewlett-Packard Modular System Interface Bus) addressing, refer to the installation and verification manual for the mainframe.

Most HP 70000 Modular Measurement Series Systems are shipped as preconfigured systems. These preconfigured systems have already had their addresses set.

If you do not have a preconfigured system, or if you want to check or change the system addressing, refer to the following pages for more information.

NOTE

The address switches on the back of the HP 70206A System Graphics display are for the display instrument only. They do NOT set the address of the system. The system address can be set using the addressing rules explained in the HP-MSIB/HP-IB Addressing section.

NOTE

When the system is first turned on, the User screen softkeys may not be visible on the CRT. This is usually caused by the display windows not being assigned. Assign the display window to an instrument, with a row address of 0, by pressing [DISPLAY], then [SELECT INSTR]. This assigns the display to the instrument with the lowest column address. Press the [^] key to assign the display to the instrument with the next-highest column address.

INITIAL INSPECTION

If you have not already done so, perform the initial inspection procedures in Section 1 of this manual.

INSTALLATION PREPARATION

Installation of the HP 70138A module into an HP 70000 Modular Measurement System requires the following steps:

Setting the module address

Installing the module in a mainframe

When properly installed, the HP 70138A obtains both power and interface-bus control through the module rear-panel mainframe/module interconnect. After the module is installed, refer to Section 4, Verification to ensure that the module is operational.

Installation Checklist

The following instructions briefly describe how to configure the vector voltmeter. For a description of the HP 70138A Vector Voltmeter's configuration, refer to Figure 2-6.

After the HP-IB cable has been installed, reset all instruments connected to the bus by cycling the power. Most plotters and printers can be reset with the front-panel reset keys or by turning the power off and on again.

Check the HP-MSIB address by pressing **[DISPLAY]** (or **[DSP]**) and **[ADDRESS MAP]**. Each address consists of a row number and a column number; for example, the vector voltmeter is typically found at row 0, column 8. Use the rotary knob to view the complete address map.

Addressing the Module

The HP 70138A needs an appropriate HP-MSIB address to allow communications with the system master. The HP 70138A module HP-MSIB address is set using the module's ROW and COLUMN address switches.

Determining the HP-MSIB Address

The HP 70138A normally has a factory-preset HP-MSIB address of row 0, column 8. Figure 2-1 shows an example of an address map (in this case, for an HP 71100A RF Spectrum Analyzer). The addresses in this figure are factory-preset for modules in this system. Refer to the installation and verification manual for the system display for instructions on how to display the instrument address map.

7				
6				
5				
4		70905A RF SECT		
3		70907A EMIM		
2		70903A IF SECT		
1				
0		70900A LO/CTLR HP-IB18		
	17	18	19	20
	COLUMN			

Figure 2-1. HP 71100A RF Spectrum Analyzer Address Map

The HP 70001A mainframe does not have an HP-MSIB address. The usual address for the HP 70205A or HP 70206A display is row 0, column 4.

NOTE

The factory-preset addressing of a HP 70138A need not be changed if it is used with other factory-preset modules (except if two or more HP 70138A's are in the same system). If other modules in a system have been changed from factory preset addresses, the HP 70138A may require to be changed.

FUNCTIONAL TERMS

Modular system devices may be combined to allow them to communicate and operate as an instrument. The following terms identify the interrelationships among devices within a modular instrument.

Element: Any device that communicates over the HP-MSIB (for example, HP 70138A Vector Voltmeter). In contrast, the HP 70001A Mainframe coordinates all HP-MSIB communications, but does not communicate over the HP-MSIB and therefore is not an element.

Master: An element that controls other elements.

Sub-master: An element that simultaneously controls other elements and is controlled by other elements.

Slave: An element that is controlled by another element.

Independent element: An element that is neither a master or a slave (for example, HP 70138A Vector Voltmeter).

Instrument: An element, or group of elements, that performs an independent function (for example, HP 71300A Millimeter Spectrum Analyzer).

STRUCTURAL TERMS

Modular systems consist of hardware structures dedicated to specific functions. The structural terms used in reference to these functions is described below:

Mainframe: A mainframe is the device into which modules may be installed to create an instrument such as a modular measurement system.

Module: Modules are devices that plug into a mainframe. They cannot function without a mainframe. The HP 70138A MMS module configuration can be changed with the use of different plug-in Input Modules.

Stand-alone Instrument: An HP-MSIB element capable of performing its functions without a mainframe (for example, HP 70206A System Graphics Display).

ADDRESS MAP PROTOCOL

Protocol for master, sub-master, slave, and independent element addressing is explained in this section. The factors governing proper system communication and system function are based on adherence to the addressing protocol of Modular Measurement Systems.

By definition, a master is an element addressed to control another element, or is the controlling element of a system. Slave elements are addressed within the area a master controls, called the slave area. Independent elements are addressed such that they are neither masters nor slaves, though they may have functions that appear to control other elements. For example, the graphics display front-panel keys are used to select the vector voltmeter functions, but the vector voltmeter is not a slave to the display.

HP-IB ACCESS

The HP-IB access area is at row 0 of the address matrix. Address row 0, column 31, however, is an illegal address location for any element. Modules that have been designed for HP-IB access are able to use the HP-IB only if their addresses are in the HP-IB access area (row 0, columns 0 through 30).

NOTE

Address row 0, column 31 is an illegal address for any element.

MASTER AND SLAVE ELEMENTS

A master is typically placed at any legal row 0 address. This row address location allows error reporting and access to HP-IB. If neither error reporting nor HP-IB access are required, a master may be placed at any legal address.

Modules controlled by another module are controlled slaves. To be controlled by a master, slave modules must be within the slave area defined by that master. Refer to Figure 2-3 for examples of modules in a slave area. For proper system function and communications, slaves must be addressed within the boundaries set by the defining elements.

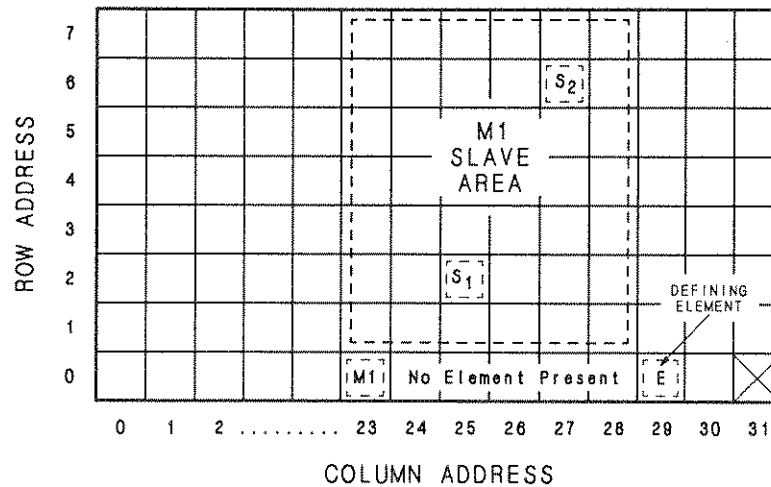

Figure 2-3. Master/Slave Address Matrix

Sub-Masters

A sub-master is an element that has the capability of functioning as both master and slave at the same time. Sub-masters are located at a row address other than 0, are controlled by another master, and control a slave area of their own. For example, Figure 2-4 illustrates sub-master M2 at address 3,24. M2 is a slave to M1. M2 also has a slave area that lies within the slave area of M1. M1 does not communicate directly with M2 slaves; it can only communicate with them through M2.

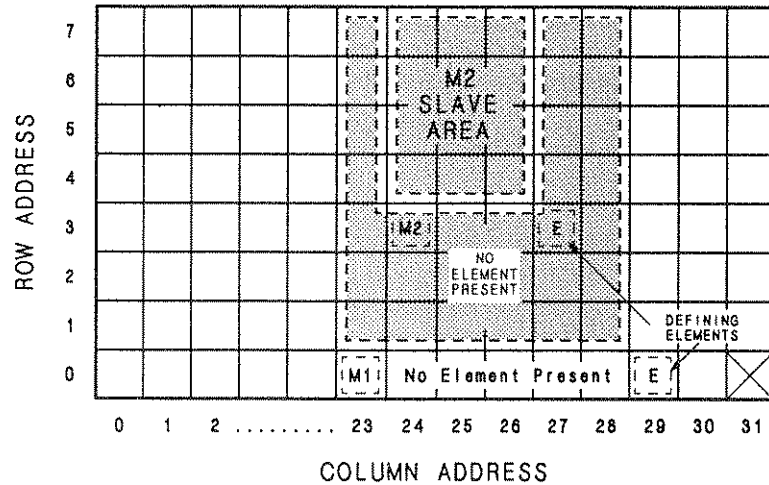

Figure 2-4. Sub-Master Address Matrix

Slave Area

For an instrument to function properly, the master must determine the slave area it controls on the address matrix. Master modules establish their slave area by determining the location of the defining element on the address matrix. The defining element establishes the boundaries of the slave area. Any module located within this area is slave to the master module.

The HP-MSIB address requirements of a defining element are as follows:

The column address of a defining element must be greater than the column address of the master. In Figure 2-3, for the master addressed in column 23, the defining element must be addressed in column 24, or above. In Figure 2-4, for M2 addressed in column 24, the defining element must be addressed in column 25 or above.

The row address of a defining element must be equal to or less than the row address of a master. In Figure 2-3, the address of the master at row 0 has a defining element addressed at row 0. Figure 2-4 shows two masters, M1 and M2. The defining element for M1 is located at row 0 and the defining element for M2 is located at row 3.

Slave Area Boundaries

After a master locates the defining element of its slave area, the slave area boundaries are set by using the following criteria:

The column address of the master is the left-hand boundary of the slave area. In Figure 2-3, the left-hand boundary is column 23.

The right-hand boundary of the slave area is equal to one less than the column address of the defining element. For the master at column 23 in Figure 2-4, the right-hand boundary is at column 28. If there is no defining element, the right-hand boundary of the slave area extends through to column 31.

The lower boundary of the slave area is one row greater than the row address of the master. For the master in row 0 in Figure 2-3, the lower boundary is at row 1.

The upper boundary of the slave area is the top row of the matrix (row 7).

If a new module is added to the area labelled "No Element Present" in Figure 2-3, this module becomes the new defining element and the right-hand boundary moves toward the master.

INDEPENDENT ELEMENTS

An independent element, such as a display, is neither a master nor a slave. Displays are considered independent elements and separate instruments. Because they do not have row address switches, displays automatically default to a row address of 0. The typical address for a display is row 0, column 4.

ADDRESSING ORDER REQUIREMENTS

HP-MSIB addresses are set by switches located on each module. The address consists of two parts: a row number and a column number. A module's address can be determined by viewing the address map or selecting the configuration screen.

ADDRESS SWITCHES

The row and column address switches set the HP-MSIB address of a module; the column address switch may also set the HP-IB address for masters and independent elements. The HP-IB address can be changed independently of the column address via the address map, using the [SET HP-IB] key.

To establish proper system function and HP-MSIB communication, each module has an address switch that is set to a binary, eight-bit HP-MSIB address. Each element in a system must be assigned a unique address. The row address of the HP-MSIB address is determined by the three lower address bits, and the column address is determined by the five upper address bits. The decimal equivalents of the binary row and column addresses are referred to throughout this manual. For example:

	Row	Column
Binary	010	11000
Decimal	2	24

Each system has 8 row and 32 column addresses. Address row 0, column 31 is an illegal address; therefore, 255 HP-MSIB addresses are available.

An eight-bit address switch is used to set the row and column HP-MSIB address for each master or slave element. There are also other address switch functions for a master and a display instrument. The address switches may be found on the top, side, or rear of the modules, and at the rear of the HP 70206A System Graphics Display. The HP 70138A address switches are on the rear panel.

HP 70138A ADDRESS SWITCHES

Figure 2-5 is an illustration of the address switches found on the HP 70138A Vector Voltmeter.

HP-IB ON/OFF With this switch set to OFF, the HP 70138A HP-IB is switched off. The HP 70138A will not respond to any HP-IB communication and will present virtually no load on the HP-IB.

Rows 1-3 These switches set the HP-MSIB row address.

Columns 1-5 These switches set the HP-MSIB column address.

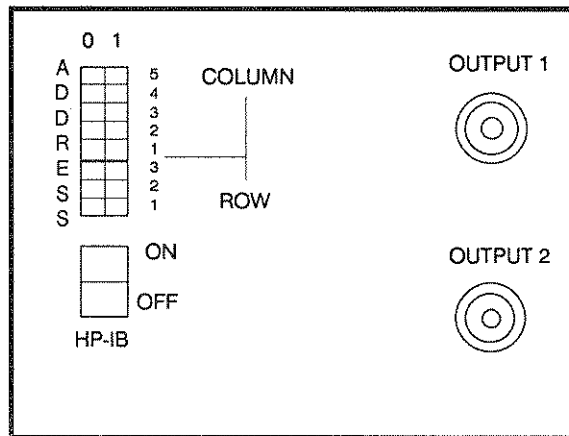

Figure 2-5. HP 70138A Address Switches

Setting the HP-MSIB Address Switches

A module-address change requires the following steps:

Locate the address switches on the rear panel of the module. See Figure 2-6 for an example of the switches.

Set the three address switches labeled “ROW” to the binary value of the module’s HP-MSIB row number. For example, if the row value is 6, set the switches to binary 110.

Set the five address switches labeled “COLUMN” to the binary value of the module’s HP-MSIB column number. For example, if the column value is 18, set the switches to binary 10010.

NOTE

Changing HP-MSIB addresses requires an understanding of HP-MSIB addressing rules. If a custom addressing configuration is used, refer to the installation and verification manuals for the other modules in the system for information on determining and assigning HP-MSIB addresses.

NOTE

Changing the HP-MSIB address will cause the HP-IB address to reset to the new value of the column address. This can be changed to a different value using the [SET HP-IB] key in the address map. If the column address is changed to 31, the HP-IB address will default to 8 since 31 is an illegal HP-IB address.

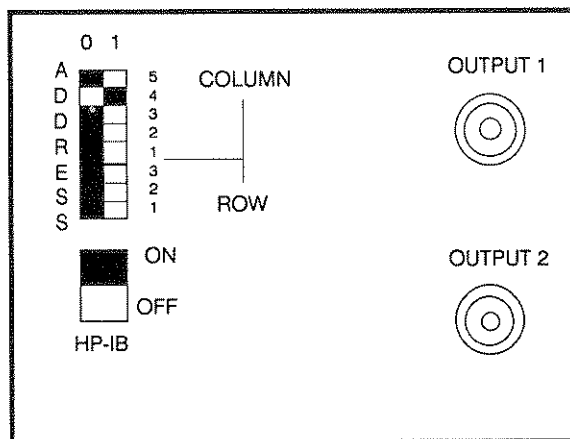

Figure 2-6. Module Address Switches

The address switches are a group of two position toggle switches. Each can be set to either 1 or a 0. In Figure 2-6, black indicates the on position for each switch to set an HP-MSIB address of row 0, column 8.

INSTALLING THE MODULE IN THE MAINFRAME

The HP 70138A must be installed in an HP 70000 Series mainframe. This is accomplished using the following procedure.

CAUTION

To avoid blowing the mainframe line fuse or internal module fuses, the mainframe power must be turned off before connecting or disconnecting modules.

1. Ensure that the LINE switch is OFF.
2. Open the front access door. Note that the door may not be opened unless the LINE switch is OFF.
3. Check the module HP-MSIB address switches for correct addressing.
4. Slide the module into the mainframe.
5. Tighten the module latch, using an 8mm hex-ball driver (HP part number 8710-1651) while pressing against the module front.
6. Close the mainframe access door.
7. Install the required Input Module (HP 85081A or HP 85082A) into the HP 70138A Vector Voltmeter.
8. Turn the mainframe LINE switch on.

INITIAL POWER-ON

The following procedures may be used for the initial system power-on:

1. Check the power cable (shipped with the system) for damage to the socket ends or the cable cord and check the voltage setting.
2. Ensure that the voltage selector is set to the correct line voltage.
3. If the cable is not damaged, set the mainframe and/or stand-alone display LINE switch to OFF. Connect the power cable(s) to the system and then to the power source.
4. Set the mainframe and/or stand-alone display LINE switch to ON. The power light should come on and the ventilation fan(s) should start.

NOTE

If the mainframe power light is on, but the ventilation fan does not start, set the mainframe LINE switch to OFF. Visually check the fan intakes at the bottom of the mainframe for blockage. If the fan intakes appear clear and there are no other obvious causes for failure, contact a Hewlett-Packard office for instructions. If the power light on the mainframe or stand-alone display is not on, check the instrument fuse.

5. When the system is started, the indicator lights on the front panel of each module will turn on and off as the modules go through their self-test routine. If there is evidence of a problem with the HP 70138A after the self-test routine (for example, the ERR light is on), refer to Chapter 5, Troubleshooting for more information.

SPECIFICATIONS

INTRODUCTION

The measurement specifications vary depending on which Input Module (HP 85081A or HP 85082A) is used with the HP 70138A.

SPECIFICATIONS

All specifications apply after the instrument's temperature has been stabilized and self-calibration routines have been run.

The instrument specifications are given in Table 1-2 of the Input Module supplement. These specifications are the performance standards or limits against which the instrument is tested. The Input Module document contains the specifications relevant when the appropriate Input Module is inserted into the HP 70138A Vector Voltmeter MMS Module.

VERIFICATION

INTRODUCTION

As the HP 70138A Vector Voltmeter cannot be performance tested without either an HP 85081A or HP 85082A Input Module installed, the full performance test information is contained in the appropriate Input Module insert.

EQUIPMENT REQUIRED

The equipment and accessories required for the performance test are listed in Table 4-1. Other equipment may be substituted if it meets or exceeds the critical specifications listed.

Table 4-1. Recommended Test Equipment

Instrument	Critical Specification	Recommended Model	Use*
Synthesized Signal Generator	Frequency Range 100kHz to 1000MHz Output Level -60dBm to +13dBm	HP 8642B	P, A, O
Power Divider	dc to 18GHz, 50ohm, Insertion Loss 6dB, Tracking <0.4dB	HP 11636A	P, A, O
DVM	Sensitivity 1mV	HP 3456A Range to 1.0V	A
AC Calibrator	Frequency Output of 20kHz Output Level 100mV \pm 20uV	Datron 4707A	A
50 ohm Termination	50 ohm, Type-N (m), SWR <1.01	HP 909A Opt 012	P, A, O
Dual Channel Synthesizer	Frequency Range 0 to 13MHz Output Level -10dBm to +19dBm Phase Offset \pm 175 deg Independent adjustment on both channels for both magnitude and phase.	HP 3326A	P
Attenuator	0 - 110dB in 10dB steps Calibration Certificate required.	HP 8496A/G Opt 890	P
Attenuator Driver	Required for HP 8496G	HP 11713A	P
RF Power Meter	100kHz to 4.2GHz (with Power Sensor) 1mW Reference Output NBS Traceable	HP 436A or HP 438A	A, P
Power Sensor	50 ohm, 100kHz to 4.2GHz SWR 1.2, 1uW to 100mW	HP 8482A	A
Oscilloscope	Bandwidth 50MHz Sensitivity 1mV/div Sweep Speed 0.2us/div	HP 54100D	A
Accessory Kit		HP 11570A	P, A, O

* P = Performance, A = Adjustment, T = Troubleshooting, O = Operation

NOTE: The HP 8496A/G attenuator should be calibrated within 0.03dB for the 10dB through 60dB steps.

DISPLAYING THE HP 70138A READINGS

1. Press the [DISPLAY] (or [DSP]) key on the Graphics Display.
2. Press the [SELECT INSTR] key.
3. Press [^] until the following message appears at the bottom of the display:
"Row X, column Y: HP 70138A, Vector VM" (where X factory preset is 0, and Y factory preset is 8).
4. Press the [USER] (or [USR]) key on the Graphics Display to display the HP 70138A Vector Voltmeter menu.

Power-On Self-Test

A module self-test is performed on all modules in an HP 70000 Modular Measurement System each time the instrument is turned on. This test verifies the ability of the module to communicate with the system controller on the system bus (HP-MSIB). During this self-test, the ACT (active) and ERR (error) status-indicator LEDs will blink on, then off, as the analyzer checks the operation of each module. If the LEDs stay on or continue to blink, refer to Section 5, Troubleshooting. The results of this test can be determined by examining the front-panel indicator LEDs and performing the following steps. The self-test routine can also be performed by selecting the [Misc] [CAL] function on the HP 70138A.



TROUBLESHOOTING

INTRODUCTION

This section provides information on the front-panel status LEDs, indicator LEDs, and the error messages produced by the HP 70138A Vector Voltmeter.

If problems are encountered, review Section 2 of this manual to ensure that the module addressing switches are properly set and the module is securely seated in the mainframe. If problems persist, refer to the installation and verification manual for the system master.

TROUBLESHOOTING TOOLS

This section contains definitions of some HP 70000 Modular Measurement System terms, and explanations of the troubleshooting tools used for isolating problems in an HP 70138A Vector Voltmeter.

Status Indicators

Error message reporting

HP 70138A Vector Voltmeter self-test

Display Tests

HP-MSIB Troubleshooting Utility

The information in this section should be read before using the procedures given in the Diagnostics Procedures section of this chapter.

STATUS INDICATORS

All elements and the mainframe have status indicators. Status indicators that inform the operator of a problem are called error indicators. Status indicators that tell the operator which elements are being controlled or accessed are called active indicators.

All elements, except the displays, have **ERR** (error) and **ACT** (active) indicator lights located on the front panel. Displays have the indicator letters **E** (error) and **A** (active). The display indicator letters are in the lower right corner of the display in the display status block. Some elements have additional status indicators:

The HP 70206A System Graphics Display has an **I/O** error indicator light on the front panel. The **I/O** light should be off when both HP-MSIB cables are either connected to, or disconnected from, the HP 70206A System Graphics Display. It should be lit only when one HP-MSIB cable is disconnected from the HP 70206A System Graphics Display. (The **I/O** light will also come on if the HP 70001A Mainframe is off.) Refer to Troubleshooting Catastrophic Failures for more information about the **I/O** error indicator.

The HP 70138A Vector Voltmeter has several HP-IB related indicators: **RMT** (remote), **LSN** (listen), **TLK** (talk), and **SRQ** (service request). **RMT**, **LSN** and **TLK** are status indicators and do not indicate an error condition when they are lit. **SRQ** can be set by the user to light in response to different conditions (for example, an error condition, or completion of an operation). Refer to the HP 70138A Vector Voltmeter programming section for information about setting **SRQ**.

The HP 70001A Mainframe does not have an active indicator, but it does have three front-panel error indicators: **VOLT/TEMP**, **CURRENT**, and **I/O CHECK**.

The **VOLT/TEMP** light indicates that the line voltage or power supply temperature needs checked.

The **CURRENT** light indicates that the loading conditions on the mainframe power supply may be incorrect.

The **I/O CHECK** light indicates that there is a communication problem.

Error Indicators

The **ERR** (error) light indicates that the element has an error condition. The error light goes out when the error condition no longer exists and the error condition has been reported.

Error conditions are reported either by an automatic error reporting routine, or when the operator presses the [REPORT ERRORS] softkey of the Display Menu.

An error indicator flashing at about a 1Hz rate indicates that the element cannot communicate on the HP-MSIB.

Active Indicators

The **ACT** (active) light of an element comes on when the element is being used through the display keyboard. Most elements also turn their **ACT** light on and off during their self-test.

The display **A** (active) letter comes on when [DISPLAY] (or [DSP]) is pressed, and may come on when Display screen softkeys are selected.

Each element turns its active indicator on when the cursor of the Address Map (Display screen) is at that particular element's HP-MSIB address. The HP-MSIB address of each element can be identified by scrolling the cursor keys through the Address Map and observing the active indicators.

ERROR MESSAGE REPORTING

Any element on the HP-MSIB that has a display link has its errors reported to the display through the automatic error-reporting routine.

If an element has a row 0 address, the errors are also available through the use of the [REPORT ERRORS] softkey in the Display screen.

Error Message Block

Error messages reported by the automatic error-reporting routine are shown in the HP 70138A Vector Voltmeter display window. See Figure 5-1.

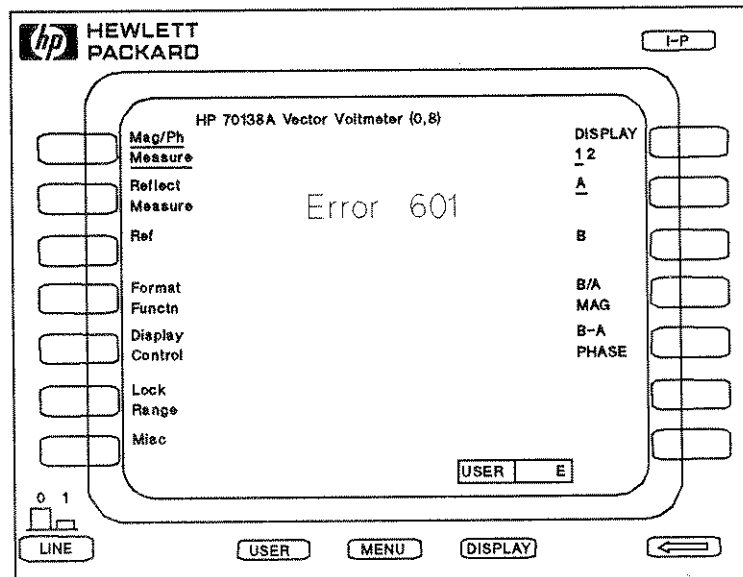

Figure 5-1. HP 70138A Vector Voltmeter Error Reporting

Error Report Screen

Errors reported by any element at row address 0 can also be seen using the [REPORT ERRORS] softkey in the Display Menu to view the Error Report screen. See Figure 5-2. The Error Report screen allows the errors to be seen whether the element has a display window or not. When [REPORT ERRORS] is pressed, the display queries all elements that are row address 0. The display E (error) letter indicates an error condition in any element on the HP-MSIB which is on row 0. All elements at row 0 report their status to the display.

The top of the Error Report screen shows the model number, description, and HP-MSIB address of the element that is reporting errors. See Figures 5-2 and 5-3.

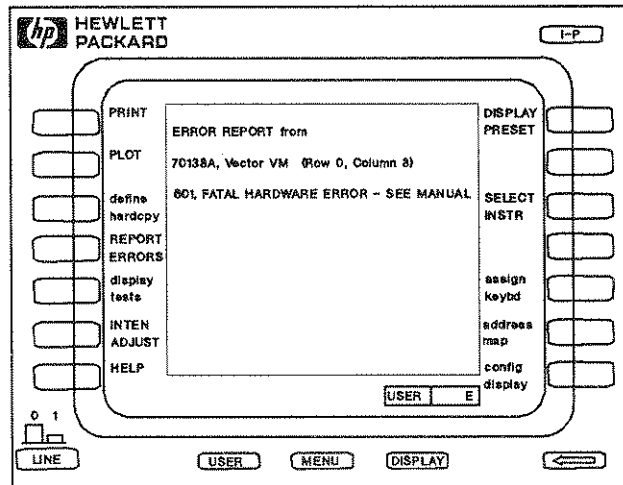

Figure 5-2. Error Report Screen

If any two elements in row 0 (including the display) are reporting errors, the Error Report screen displays the errors of the element with the lowest column address and a [MORE ERRORS] softkey. Pressing [MORE ERRORS] displays the errors of the element with the next-highest column address. See Figure 5-3.

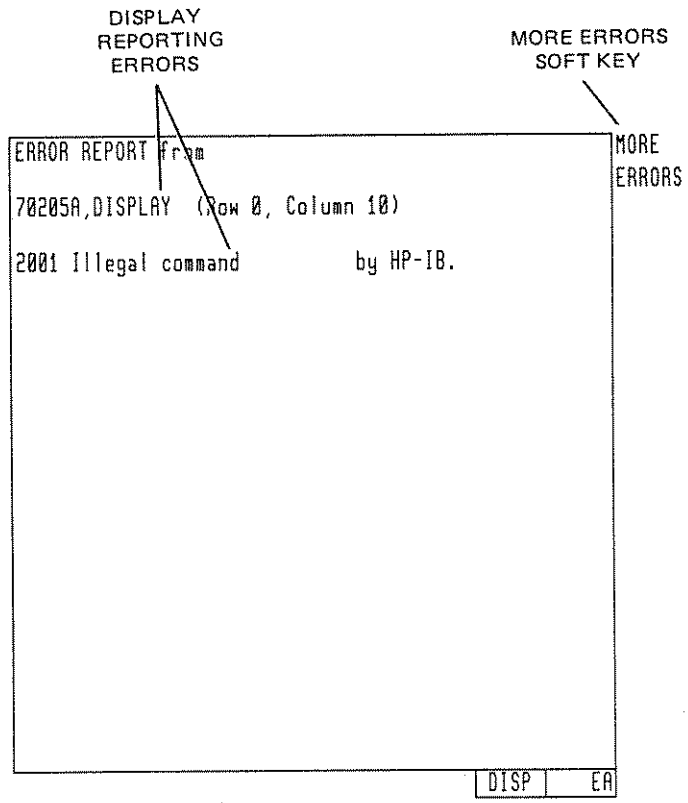

Figure 5-3. [MORE ERRORS] Softkey

To exit the Error Report screen, press the either the **[USER]** (or **[USR]**) or **[MENU]** (or **[MNU]**) key.

HP 70138A VECTOR VOLTMETER SELF-TEST

To help in determining whether the HP 70138A is faulty or not, a series of self test routines are run at instrument power up or when the [Misc] [CAL] routine is initiated. During the test routines, the display will indicate 'TEST XXX' (where 'XXX' is a three-digit code that indicates which of the internal assemblies are being tested). Normally, these displays may not be seen (due to either the speed of the test, or the warm-up time of the display). However, if a faulty assembly is detected, the display may indicate 'ERR XXX'. Also, if the display indicates the same test display for longer than 10 seconds, an error condition exists.

Table 5-1 indicates the Error Code numbers and the assembly in the HP 70138A to which they refer.

Table 5-1. Error Codes

Error Code	Assembly	Designation
200	Power Supply	A6
300	IF Assemblies	A2, A3
400	Search and Lock	A4
500	Processor	A5
600	Input Module	(refer to Input Module manual)

Should the self-test routines produce an error indication, they should be re-run to verify that the problem persists. However, before replacing the HP 70138A, check the power supply levels, cables and connections, and adjustments relating to the assembly indicated by the error code.

The replacement HP 70138A (HP part number 70138-69100) is fully calibrated and tested.

NOTE:

It is possible that a four-digit error code will be displayed. Should this type of error code appear, the instrument power should be cycled. If the error reappears, contact your local HP Service Office.

EXCHANGING THE HP 70138A

CAUTION

Module exchange should only be performed at a static-safe work station. Refer to the anti-static information in the General Information section of this manual.

When you receive the exchange unit it will be complete except for labeling information. Therefore, you will need to replace the front frame of the exchange module with the front frame of the faulty module.

Removing the Module from the Mainframe

1. Set the LINE switch to OFF.
2. Disconnect any cables from the module rear panel connectors.
3. Open the mainframe front access door. Note that the door may not be opened unless the LINE switch is OFF.
4. Remove the Input Module (HP 85081A or HP 85082A) from the HP 70138A Vector Voltmeter.
5. Loosen the module latch using an 8mm Hex-ball driver (HP part number 8710-1651).
6. Slide the module forward out of the mainframe.

Removing the Module Front Frame

1. Remove the four screws from the cover top, and the four screws from each of the cover sides. Lift off the cover.
2. Remove the four front panel mounting screws from the rear of the front frame. The front panel will now be loose and restrained only by a ribbon cable.
3. Remove the three front frame mounting screws at the bottom of the front frame.
4. The front frame can now be carefully removed from the front panel.

In situations where it is necessary to replace the entire front panel, continue with the following procedure.

1. Disconnect the PROBE POWER connector from the front panel circuit board.
2. Unsolder and disconnect the TEST connector resistor from the front panel circuit board.
3. Remove the four screws holding the front panel circuit board to the front panel.
4. The front panel can now be removed.

Replacing the Module Front Frame

Replacement of the front frame and front panel is the reverse of the removal procedure. After assembling the front frame, you will need to align the front panel. Alignment of the front panel is best achieved by laying the HP 70138A on its left side on a flat surface. The Front Panel should then be adjusted until it is aligned with the left and top sides of the Front Frame. The fixing screws should then be tightened.

Reinserting the Module in the Mainframe

1. Ensure that the LINE switch is OFF.
2. Open the front access door. Note that the door may not be opened unless the LINE switch is OFF.
3. Check the module HP-MSIB address switches for correct addressing.
4. Slide the module into the mainframe.
5. Tighten the module latch, using an 8mm hex-ball driver (HP part number 8710-1651) while pressing against the module front.
6. Close the mainframe access door.
7. Install the required Input Module (HP 85081A or HP 85082A) in the HP 70138A Vector Voltmeter.
8. Turn the mainframe LINE switch on.

Instrument Serial Number

In addition to the Serial Number plate located on the front frame of the HP 70138A, the instrument serial number is also resident in the EEPROM. When the HP 70138A is re-installed in the MMS mainframe, the EEPROM must also be updated. Use the following procedure to update the EEPROM.

1. Ensure that the MMS mainframe power is switched off.
2. Remove the four screws from the cover top, and the four screws from each of the cover sides. Lift off the cover.
3. Connect the HP 70138A to the MMS mainframe using the MMS Module Extender (HP part number 70001-60013).
4. Set the Test Switch (located at the top edge of the A5 Processor Assembly) to position 'D'.
5. Switch on the MMS mainframe power.
6. Press **[DISPLAY]** (or **[DSP]**), then **[SELECT INSTR]**. Press **[^]** until the HP 70138A ACT LED lights.
7. Select **[USER]** (or **[USR]**) **[I/P]**.
Press **[Misc] [7] [0] [1] [3] [8]**
Press **[Misc] [selfst menu]**.

A serial number will now be displayed on the screen.

8. Select [SERIAL NUMBER] and enter the required serial number using the numeric keypad.

Nine digits have to be entered. The firmware will automatically skip over the country of origin character. Corrections can be made using the backspace ([<]) key.

9. When the correct number has been entered, press [ENTER]. This will store the serial number in the instrument firmware.

NOTE: Pressing [CLEAR] or [HOLD] will cancel the serial number entry.

10. Once the serial number has been entered and stored, set the Test Switch on the processor board to '0'. Replace the top cover. The HP 70138A is now ready to use in normal operation.

DIAGNOSTIC PROCEDURES

As the HP 70138A is repaired by replacing the entire unit with an exchange unit, the only diagnostic procedures available are the HP 70138A self tests.

CATEGORIZING FAILURES

Most system problems can be isolated using either the Troubleshooting from the Front Panel, or the Troubleshooting over HP-IB. However, because this troubleshooting information is dependent upon running troubleshooting routines, it is not useful when there is a catastrophic failure.

Catastrophic failures prevent the system from running troubleshooting routines. These failures usually result in a blank or distorted CRT screen, flashing error lights, or no [USER] or [MENU] screen softkeys.

The following procedure allows categorization of system failures, and directs you to the troubleshooting information that will be the most helpful. Before beginning this procedure, make a note of any error messages that are present.

1. Power off and then power on the system and wait about 10 seconds.
2. If the display instrument (for example, HP 70205A) is faulty, refer to the appropriate Service Manual for further troubleshooting and repair information.
3. If the ERR LED on a module is flashing at a 1Hz rate, the module cannot communicate over the HP-MSIB.
4. If the [USER] screen softkeys are shown on the CRT, the problem is not caused by a catastrophic failure. If a problem still exists, use the Troubleshooting from the Front Panel, or Troubleshooting over HP-IB sections on the following pages.
5. If the CRT does not show the [USER] screen softkeys, use the following steps to assign the display window.
 - a. Press [DISPLAY] (or [DSP]).
 - b. Press [SELECT INSTR].

NOTE

If there is more than one system on the HP-MSIB, the [SELECT INSTR] softkey assigns the display window to the element with the lowest HP-MSIB column address. If you do not want to test this element, press the [^] key to select the element with the next-highest HP-MSIB column address. In this manner, you can assign the display window to any element.

5. Press the [USER] (or [USR]) key.

- a. If the [USER] screen softkeys for the element are shown on the CRT, the problem is not caused by a catastrophic failure in that element. If a problem still exists, use the Troubleshooting from the Front Panel or Troubleshooting over HP-IB sections on the following pages.
 - b. If the [USER] screen softkeys fail to appear, try another element. If they still fail to appear, the system has a catastrophic failure. Refer to Troubleshooting Catastrophic Failures for further information.
-

NOTE

If the display window assignment is lost when the instrument is turned off, the display battery needs replacing. A dead battery will result in the error message 6008 Confidence Test Failed being displayed at power-on. When the [REPORT ERRORS] softkey on the Display screen is pressed, the error message 6002 A6 RAM Check Sum will be displayed.

To gain access to the battery, remove the screws from the BATTERY cover at the rear of the stand-alone display or the display module.

TROUBLESHOOTING FROM THE FRONT PANEL

The following procedure uses most of the troubleshooting tools of the system. Before attempting to diagnose an instrument failure, use this procedure to collect all possible clues.

The display instrument will be tested first. Use the procedure below to run Confidence Test (the self-test of the display instrument).

- a. Press [DISPLAY] (or [DSP]).
- b. Press [DISPLAY TESTS].
- c. Press [CONFID TEST].
- d. The display indicates on the CRT title line whether the Confidence Test passed or failed. If the Confidence Test **failed**, press [REPORT ERRORS]. Record the errors and refer to the Service Manual of the appropriate display to repair the faulty display instrument. If the Confidence Test **passed**, continue with this procedure.

TROUBLESHOOTING THE HP 70138A

The HP 70138A MMS Vector Voltmeter is a dual-channel IF processor that receives two 20kHz signals from the Input Module. The HP 70138A measures these signals to determine the amplitude and phase characteristics. The results of this measurement are presented on the MMS Display Module and are also available at the HP-IB programming interface. In addition, dc representations and real-time outputs of the amplitude and phase values are available on the instrument rear panel. Instrument operation is under control of a digital processor which also has built in routines to provide the data in a number of different formats.

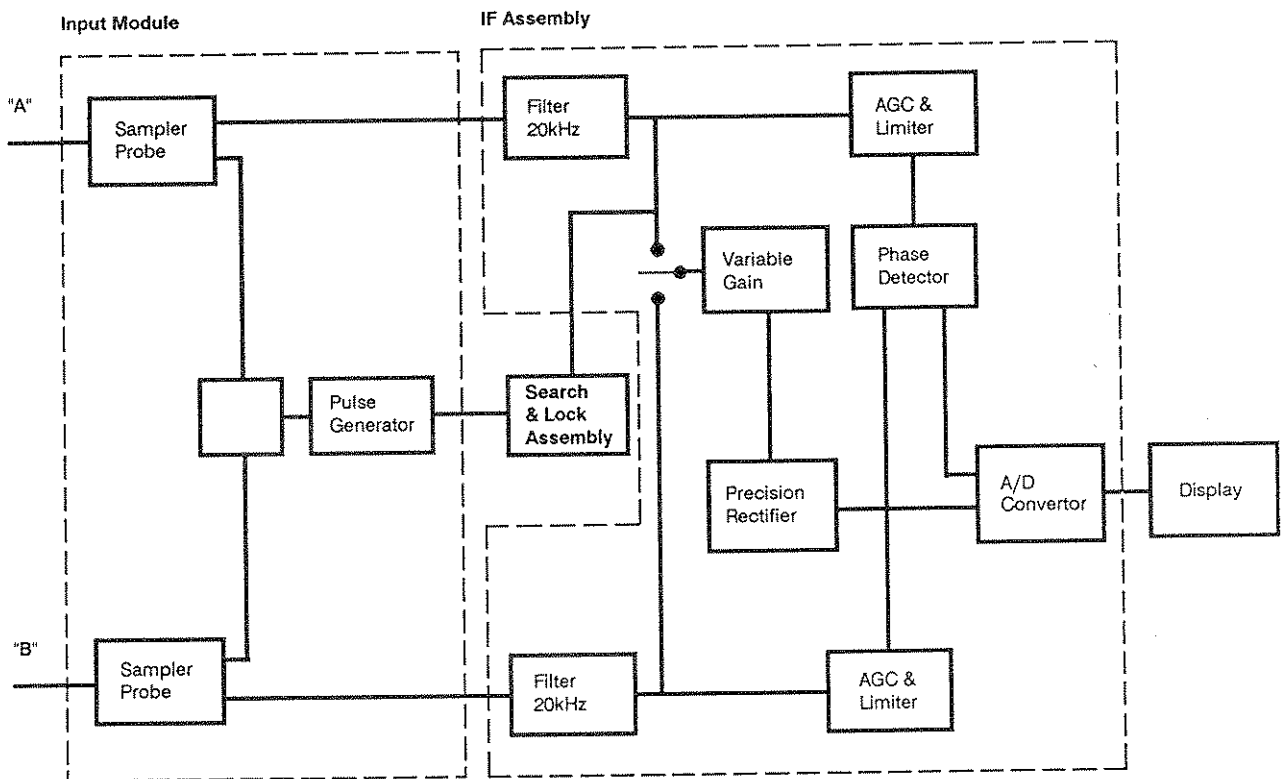

Figure 5-4. Simplified Block Diagram of the HP 70138A MMS Vector Voltmeter

The HP 70138A is not repairable to assembly or component level. If the unit should develop a fault, an exchange unit (HP part number 70138-96100) should be installed.

To help in determining if the HP 70138A is faulty, a series of self test routines are run whenever the instrument power is switched on or when the [Misc] [CAL] routine is initiated. During the self test routines, the display will indicate 'TEST XXX' (where 'XXX' is a three-digit code that indicates which of the internal assemblies is being tested). Normally, these displays may not be seen (due to either the speed of the test, or the warm-up time of the display). However, if a faulty assembly is detected, the test code will be retained on the display.

Table 5-2 indicates the Error Code numbers and the assembly in the HP 70138A to which they refer.

Table 5-2. Error Codes

Error Code	Assembly	Designation
200	Power Supply	A6
300	IF Assemblies	A2, A3
400	Search and Lock	A4
500	Processor	A5
600	Input Module	(refer to Input Module manual)

Should the self-test routines produce an error indication, they should be re-run to verify that the problem persists. However, before replacing the HP 70138A, check the power supply levels, cables and connections, and adjustments relating to the assembly indicated by the error code.

The replacement HP 70138A (HP part number 70138-69100) is fully calibrated and tested.

NOTE:

It is possible that a four-digit error code will be displayed. Should this type of error code appear, the instrument power should be cycled. If the error reappears, contact your local HP Service Office.

TROUBLESHOOTING OVER HP-IB

Troubleshooting over HP-IB is recommended only if you do **not** have access to a display instrument (for example, HP 70205A).

The following remote commands can be used from an external HP-IB computer:

*TST? begins the Self-Test routine of the HP 70138A Vector Voltmeter. The response will be either "0" for a pass or "1" for a fail.

The **SYSTEM: ERR? STR** query returns a text description of one error. If there is more than one error, repeat the query until the response is "0, NO ERROR".

TROUBLESHOOTING CATASTROPHIC FAILURES

Catastrophic failures prevent the system from running most troubleshooting routines. These failures usually result in an abnormal CRT screen, no [USER] (or [USR]) or [MENU] (or [MNU]) screen softkeys, or flashing error lights. Where additional controllable elements exist, try selecting another one to verify the source of failure.

NOTE

Before troubleshooting a catastrophic failure, verify that the correct line power is applied to the mainframe (and stand-alone display, if used). The mainframe power-on indicator should light when the LINE switch is turned on. If the power-on indicator does not light, refer to the HP 70001A Mainframe Service Manual for troubleshooting information.

Abnormal CRT Screen

This section contains troubleshooting information for the following symptoms: blank or distorted CRT display, message written in large block letters on the CRT display, and the CRT showing the Display ID screen.

Blank or distorted CRT display

If a display module (for example, HP 70205A) has a blank or distorted CRT display after power to the system is cycled, the display module is faulty. Refer to the appropriate Service Manual for further troubleshooting and repair information.

If a stand-alone display (for example, HP 70206A) has a blank or distorted CRT display, disconnect the HP-MSIB cables and cycle power on the stand-alone display. If the CRT is still blank or distorted, the stand-alone display is faulty. Refer to the appropriate Service Manual for repair information.

Blank CRT (except for message written in large block letters)

The message is a display-disruptive message. It indicates a faulty display instrument. Refer to the appropriate Service Manual for repair information.

CRT shows Display ID screen

The Display ID screen shows the following information about the display instrument: model number, firmware version, HP-MSIB address, and Dot Generator release date. If this information is shown on the CRT, either the display window is not assigned to an element, or the display cannot talk to an element.

Assign the display window to an element by pressing **[DISPLAY]**, then **[SELECT INSTR]**. This assigns the display to the element with the lowest column address. Press the **[^]** key to assign the display to the element with the next-highest address.

If the display window cannot be assigned to an element, then a module with a faulty HP-MSIB interface is hanging-up the system, or the HP-MSIB, or the element is faulty. First check the HP-MSIB cabling then refer to Using the HP-MSIB Troubleshooting Utility to further troubleshoot the problem.

NOTE

If the display window assignment is lost when the instrument is turned off, the display battery needs replacing. A dead battery will result in a 6008 Confidence Test Failed error message at power-on and a 6002 A6 RAM Check Sum error message when you press the **[REPORT ERRORS]** softkey (Display screen).

To gain access to the battery, remove the screws from the BATTERY cover at the rear of the stand-alone display or the display module.

Missing User or Menu Screen Softkeys

If the **[USER]** (or **[USR]**) or **[MENU]** (or **[MNU]**) screen softkeys are missing, press **[DISPLAY]**, then **[SELECT INSTR]** to assign the display window to the element with the lowest column address. Press the **[^]** key to assign the display to the element with the next-highest address.

Press **[USER]** (or **[USR]**) or **[MENU]** (or **[MNU]**). If the User or Menu screen softkeys are still missing, refer to Using the HP-MSIB Troubleshooting Utility to further troubleshoot the problem.

Error Lights

This section contains troubleshooting information for the following symptoms: flashing E (error) letter or flashing ERR (error) light, lit I/O indicator on the HP 70206A System Graphics Display, and lit VOLT/TEMP, CURRENT, or I/O CHECK on the HP 70001A Mainframe.

Flashing E (error) letter or ERR (error) light

If the E letter or the ERR light of an element flashes at a 1Hz rate, the element cannot talk on the HP-MSIB and is probably faulty. If more than one module flashes its error indicator at a 1Hz rate; either the mainframe HP-MSIB is faulty, a faulty module is disrupting the whole HP-MSIB, or the HP-MSIB cables are faulty. (It is possible, but not probable, for a module to disrupt the whole HP-MSIB without flashing its own error indicator.) Refer to Using the HP-MSIB Troubleshooting Utility (later in this section) to further isolate the problem.

The I/O indicator on the HP 70206A System Graphics Display is lit

The HP 70206A System Graphics Display I/O indicator light should be off when both HP-MSIB cables are either connected to or disconnected from the HP 70206A. It should be lit when only one HP-MSIB cable is connected to the HP 70206A. Follow the troubleshooting procedure to isolate other causes of the I/O indicator being lit:

1. Verify that all mainframes and stand-alone displays on the HP-MSIB have their power turned on.
2. Check for proper HP-MSIB cable connections, making sure all cable connections are secure.
3. Disconnect the HP-MSIB cables from the HP 70206A.
 - a. If the I/O indicator is still lit, the HP 70206A System Graphics Display is faulty. Refer to the HP 70206A System Graphics Display Service Manual for further troubleshooting and repair information.
 - b. If the I/O indicator is not lit, the problem is either in the cables or in the instrument that was connected by the cables to the HP 70206A System Graphics Display. Reconnect the HP-MSIB cables and use the HP-MSIB Troubleshooting Utility (later in this section) to further isolate the problem.

NOTE

If any of the elements respond to the HP-MSIB Troubleshooting Utility with COMMUNICATION COMPLETE, the cables are not faulty.

HP 70001A Mainframe I/O CHECK indicator is lit

The I/O CHECK light should be off when both HP-MSIB cables are either connected to, or disconnected from, the HP 70001A Mainframe. The I/O CHECK light should be lit when only one HP-MSIB cable is connected to the mainframe.

To isolate other causes of the I/O CHECK light being lit, use the following procedure.

1. Verify that all mainframes and stand-alone displays on the HP -MSIB have their power turned on.
2. Check for proper HP-MSIB cable connections, making sure that all cable connections are secure.
3. Disconnect the HP-MSIB cables from the mainframe.
 - a. If the I/O CHECK light is still lit, the HP 70001A Mainframe is faulty. Refer to the HP 70001A Mainframe Service Manual for further troubleshooting information.
 - b. If the I/O CHECK light is no longer lit, the problem is either in the cables or in the instrument that was connected by the cables to the mainframe. Reconnect the HP-MSIB cables, and refer to Using the HP-MSIB Troubleshooting Utility to further isolate the problem.

NOTE

If an element outside of the mainframe responds to the HP-MSIB Troubleshooting Utility with COMMUNICATION COMPLETE, the cables are not faulty.

HP 70001A Mainframe VOLT/TEMP indicator is lit

The VOLT/TEMP indicator usually lights if either the input voltage is too low, or the internal temperature on the mainframe power-supply board assembly exceeds the normal operating temperature.

1. Check the LINE VOLTAGE SELECTOR on the bottom of the mainframe to make sure the selector setting matches the line voltage.
2. Allow the instrument to cool. If the temperature decreases to normal operating range, the mainframe will attempt to restart itself. After the instrument has restarted, verify that the cooling fans are operating by visually checking the airflow into both fan-intake openings in the rear panel of the mainframe.

If neither of the above steps result in correction of the problem, the HP 70001A Mainframe is faulty. Refer to the HP 70001A Mainframe Service Manual for further troubleshooting and repair information.

HP 70001A Mainframe CURRENT indicator is lit

The CURRENT indicator lights when a module in the mainframe is drawing too much current.

1. Remove one module from the mainframe.
2. Cycle the power.
 - a. If the CURRENT indicator is no longer lit, the module is faulty. Verify this by replacing the module in the mainframe and seeing if the CURRENT indicator lights again. Refer to the appropriate Service Manual for repair information.
 - b. If the CURRENT indicator is still lit, that particular module is not faulty. Repeat steps 1 and 2 until the faulty module is identified.
3. If the CURRENT indicator is still lit, when all of the modules have been removed from the Mainframe, the mainframe is faulty.

USING THE HP-MSIB TROUBLESHOOTING UTILITY

The HP-MSIB Troubleshooting Utility is a firmware routine of the display instrument. It allows you to verify that an element can communicate on the HP-MSIB. By determining which elements can communicate, you can isolate the HP-MSIB problem. However, if the problem is in the mainframe or the display, the utility cannot determine which is faulty.

Preparing to Use the Utility

To use the utility, you must know the HP-MSIB addresses of the elements. It is recommended that you keep a written list of all the HP-MSIB addresses.

NOTE

The address map may not function if there is an HP-MSIB problem. After an HP-MSIB problem occurs, the Address Map cannot be relied upon to determine the address of the elements.

If you do not know the HP-MSIB addresses, they can be identified by checking the switch settings on each module. The HP-MSIB addresses can also be deduced from the response of the troubleshooting utility, and the addressing rules given in the HP-MSIB/HP-IB Addressing section of Section 2.

NOTE

The HP-MSIB Troubleshooting Utility inhibits normal operation of the system. Using the utility may put the system in a state from which you can only recover by cycling power.

Purging Window Assignments

When the HP-MSIB is not working, the troubleshooting utility cannot be used unless the display is prevented from automatically communicating with other HP-MSIB elements. This is done by purging all window assignments of the display.

The [SHOW CONFIG] softkey of the Display screen shows which windows are assigned. Use the following procedure to purge window assignments.

1. Press the [DISPLAY] (or [DSP]) key.
2. Press [config display].
3. Press [purge window].
4. Select the window to be purged by pressing the [^] or [v] key. (The window number selected is shown at the lower left-hand corner of the screen.)
5. Press [EXECUTE] to purge the window.
6. Repeat steps 2 through 5 until all windows are purged.
7. Cycle power.

When all window assignments are purged, the User screen will blank, except for the status block.

Using the Utility

Use the following procedure to access the HP-MSIB Troubleshooting Utility.

1. Press [DISPLAY] (or [DSP]).
2. Press [display tests], then [KNOB TEST]. The CRT display should be similar to the one shown in Figure 5-5. Note that the Knob Test value is 00.
3. With the Knob Test value at 00, press the lower left-hand softkey (unlabeled).

The HP-MSIB Troubleshooting Utility is now displayed as illustrated in Figure 5-6. This utility is entered through an unlabeled softkey to prevent users from accidentally disrupting normal system operation.

test
pattern

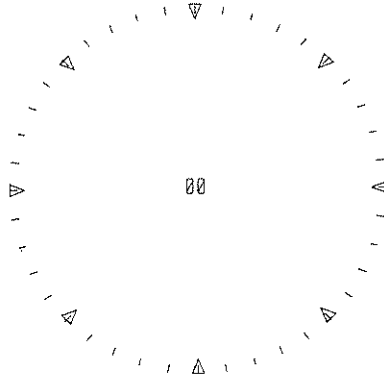

DISPLAY
ID

KNOB
TEST

KEY
TEST

CONFID
TEST

TUMBLE
FIGURES

DSPL | T | A

Figure 5-5. Knob Test Display

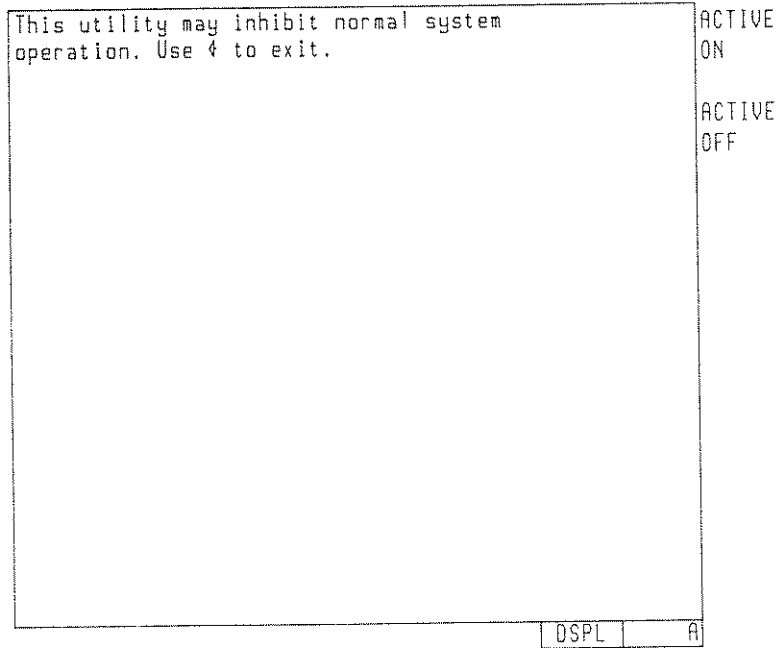

Figure 5-6. HP-MSIB Troubleshooting Utility

The utility has two main softkeys: [ACTIVE ON] and [ACTIVE OFF]. (See Figure 5-7.) These softkeys send the HP-MSIB command to turn the active indicator of an element on and off.

Once the command is sent, the display examines the HP-MSIB to see if the element received the instruction. Use the following procedures to send the Active On command.

1. Press [ACTIVE ON].
2. Using the numeric key pad, enter the row address of the module that is to be tested for an HP-MSIB failure.
3. Press [ENTER].
4. Enter the column address of the module as a hexadecimal number. Refer to Table 5-3 for decimal-to-hexadecimal conversion information. Use the alphabetical softkeys (Figure 5-7) and the key pad to enter the hexadecimal numbers.
5. Press [ENTER].

Table 5-3. Decimal/Hexadecimal Conversion

Decimal	Hexadecimal	Decimal	Hexadecimal
0	0	16	10
1	1	17	11
2	2	18	12
3	3	19	13
4	4	20	14
5	5	21	15
6	6	22	16
7	7	23	17
8	8	24	18
9	9	25	19
10	A	26	1A
11	B	27	1B
12	C	28	1C
13	D	29	1D
14	E	30	1E
15	F	31	1F

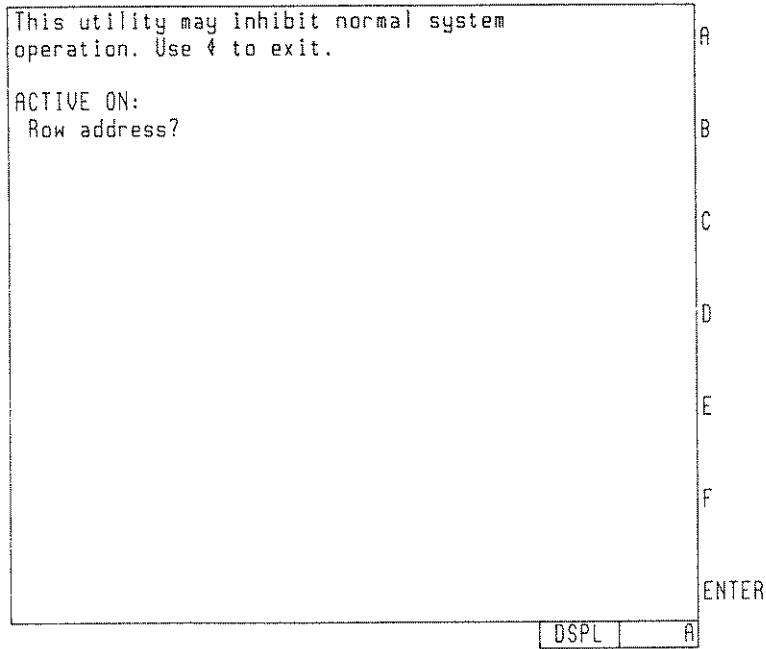

Figure 5-7. Alphabetical Softkeys

The utility has a two-second time-out. Allow two seconds for the utility to respond to the [ENTER] softkey. The utility responds by displaying one of the following messages. (Example messages are shown in Figure 5-8.)

Module not accepting data. This message indicates that there is an element at the specified address, but it cannot communicate on the HP-MSIB.

Communication complete. This message indicates that the HP-MSIB of the element works correctly. Note that the active light on the module should be ON.

Module not present. This message indicates that there is no element at the specified address.

```

This utility may inhibit normal system
operation. Use ^ to exit.
ACTIVE ON:
Row address? 4
Column address? 5
Module not present
ACTIVE ON:
Row address? 1
Column address? 1C
Communication complete
ACTIVE OFF:
Row address? 1
Column address? 1C
Communication complete

```

A
R
C
D
E
F
ENTER

DSPL | A

Figure 5-8. Completed HP-MSIB Communication

Interpreting the Utility Results

If only one module cannot communicate on the HP-MSIB, that module is faulty. Refer to the appropriate Service Manual for troubleshooting and repair information.

If none of the elements on the HP-MSIB can communicate, either a module is disrupting the entire HP-MSIB, the mainframe HP-MSIB circuits are faulty, or the display instrument has a faulty HP-MSIB interface and the utility is giving erroneous results. Use the following steps to further isolate the problem.

1. If an abnormal CRT screen is a symptom, refer to both the HP 70001A Mainframe Service Manual and the appropriate display Service Manual for further troubleshooting and repair information.
2. If flashing error lights are a symptom, the faulty element or mainframe can be isolated by using the following steps.

NOTE

Turn the mainframe OFF before removing the module from the mainframe.

- a. Remove the element from the HP-MSIB by removing the module from the mainframe, or by disconnecting the HP-MSIB cables from a stand-alone element.
- b. Cycle the power.

c. If the problem is gone, the element is faulty. Refer to the appropriate Service Manual for further troubleshooting and repair information.

d. If the problem remains, repeat steps a through c until the faulty element has been isolated. If none of the elements are faulty, the HP 70001A Mainframe is faulty. Refer to the HP 70001A Mainframe Service Manual for further troubleshooting and repair information.

ERROR MESSAGES

The HP 70138A will generate error messages only if an incorrect instrument hardware state is detected during a [CAL] operation or a power-on self test. An incorrect firmware state will result in a four-digit error display. Both will inhibit further operation of the instrument.

When an error message is generated, the "ERR" annunciator on the front panel of the Vector Voltmeter illuminates. The resulting error message can be viewed in one of two ways:

1. If the Vector Voltmeter's readings are on the display, the error message will be displayed on the screen.
2. Regardless of which Vector Voltmeter's readings are on the display, the Modular Measurement System will place a small 'e' in the lower right corner of the display. The error message can be viewed by using the following procedure:
 - a. Press the [DISPLAY] (or [DSP]) key.
 - b. Press the [REPORT ERRORS] key.

Module Self-Test

During module self-test, which occurs each time the instrument is turned on, the LEDs will blink on momentarily as the instrument activates and checks the module. If the LEDs continue to blink, or remain lit, this is an indication of a problem.

STATUS ACT

The ACT LED turns on when:

1. The module is performing a function directed by manual control of the display keyboard.
2. The instrument is in self-test mode.

STATUS ERR

The module error indicator, the **ERR LED**, indicates when the module is in an error condition.

The **ERR LED** flashes at a 1Hz rate when communication over HP-MSIB is not satisfactorily completed.

NOTE

It is possible that a module may disrupt all HP-MSIB communication without its own error indicator flashing.

Status-indicator problems can be isolated by substituting master, mainframe, or modules. Since there are no operator adjustments or repairs, problems should be referred to qualified technical personnel.

Hardware Warning Errors

These error codes report the status of the HP 70138A hardware. An error indicates that some of the hardware is not functioning properly. Measurement accuracy may be impaired.

Hardware errors are listed for information only. The HP 70138A Vector Voltmeter has no operator repairs or adjustment. Repairs should only be attempted by qualified technical personnel.

