



modular measurement system

MMS

Modular Measurement System

HP 70000 Family



Catalog Highlights

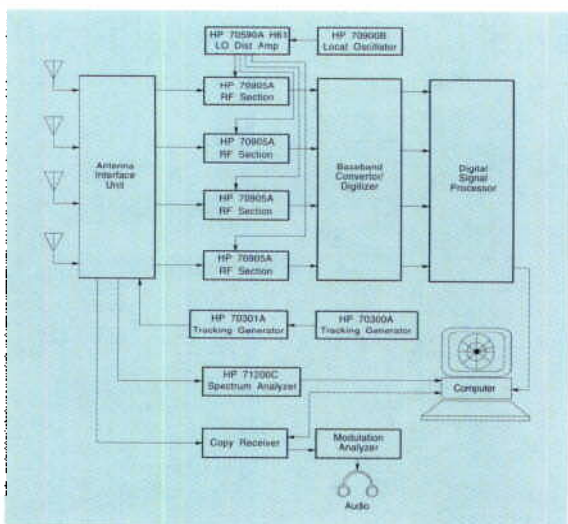

Configuration Examples

See how MMS can work for your application. (direction-finding receiver, above)



Instruments

Single-module instruments can be integrated to meet your needs. (power meter, above)

Table of Contents

3 MMS Overview

The HP 70000 modular measurement system (MMS) is an integrated family of test equipment especially suited for high performance RF, microwave, and lightwave applications. This measurement platform offers the lowest life cycle cost when you integrate, support, or upgrade your test system.

9 Configuration Examples

You can integrate multiple MMS instruments into a complete measurement solution. The MMS platform contributes uniquely to the success of many programs, both commercial and military.

13 Instruments

Choose from instruments that are single modules or multiple modules configured into systems. More than 40 different modular components are available, including mainframes, displays, modules, and systems.

114 System Integration

Quickly integrate your test system using the resources and tools available. Save development time using HP's custom switch matrixes. Or design your own modules using development products and engineering resources available from HP and other vendors.

134 System Building Blocks

Configure an instrument or system for unique applications using off-the-shelf modules. Schematics show inputs, outputs, and the major functional blocks contained in each module.

167 Customer Support

HP provides product support and services, including calibration, performance test software, hotline support, documentation, and equipment requirement information.

173 Alphabetical and Numerical Indices

Locate products by product model number or product type.



modular measurement system

Catalog Highlights

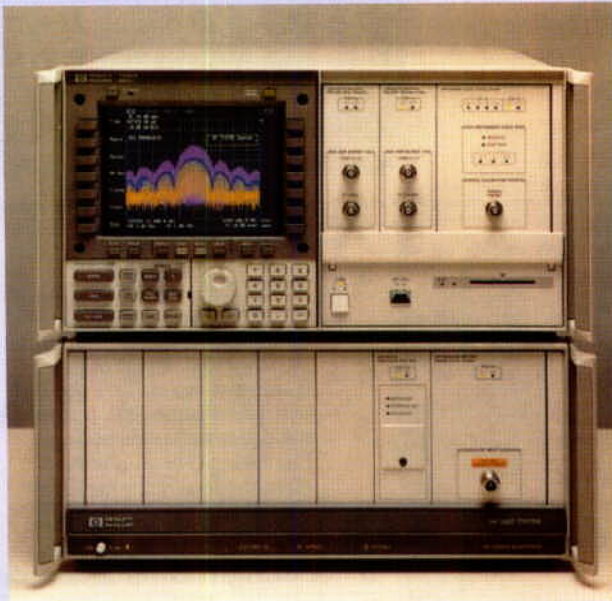

Modular Instrument Systems

Use multi-module instruments to build an array of applications. (spectrum analyzer workstation, above)

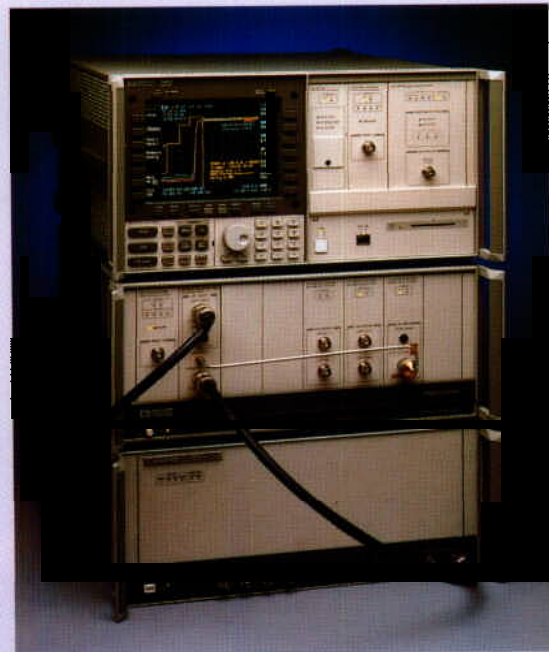

System Integration

Integrate your test system with MMS tools.

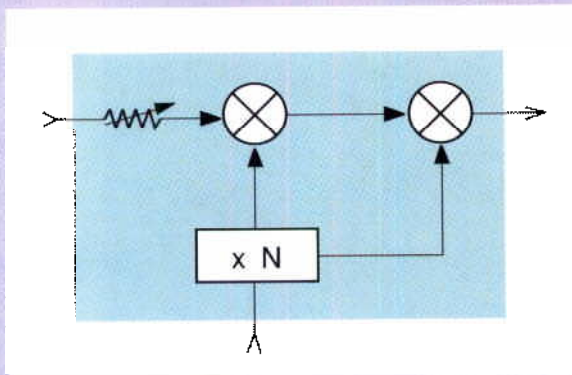

System Building Blocks

Configure instruments and systems for unique applications.

Introduction

MMS Overview

The microwave standard

The modular measurement system (MMS) is the high performance instrument system that provides the lowest life-cycle cost for high frequency test systems, from RF and microwave to lightwave. The MMS helps you reduce cost, save time, and minimize risk when integrating, using, supporting, or upgrading measurement systems. Test systems can be optimized by combining MMS with other systems.

MMS architecture

MMS is a modular architecture with a well-defined environment optimized for RF and microwave instrumentation. It addresses the industry need for downsized, modular instrumentation that can share common system components. Numerous off-the-shelf system components—including mainframes, modules, and software—are available from HP and other manufacturers. Because the system is open, manufacturers and system integrators can leverage existing hardware and software by building additional components of their own.

Quick system configuration

System integrators can quickly configure modular test systems. Modularity allows systems of all sizes to be tailored easily to suit your requirements. Many special hardware and software products and services to customize systems are available from HP and other vendors, helping reduce the need to do custom work. Several design tools and resources are also available for designing and building custom modules. Customization can proceed quickly because the system architecture is already defined and many components are available.

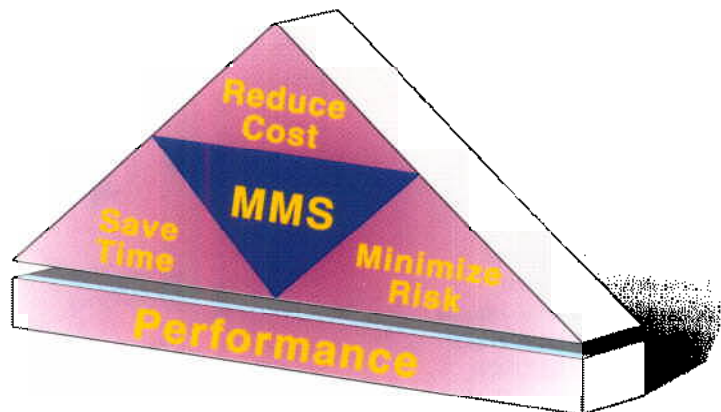

MMS benefits

Expanding functionality

Many MMS products are available today. Choose from more than 40 modules, displays, mainframes, and standard instrument systems. MMS functionality continues to expand with many new products from HP and other companies introduced every year.

Smaller than rack-and-stack

Since MMS instruments are smaller and weigh less than traditional HP-IB instruments, rack volume is used more efficiently. A central, shared display/user interface eliminates display and front-panel redundancy. When the display is not needed, it can be removed from the system, saving even more space and reducing cost.

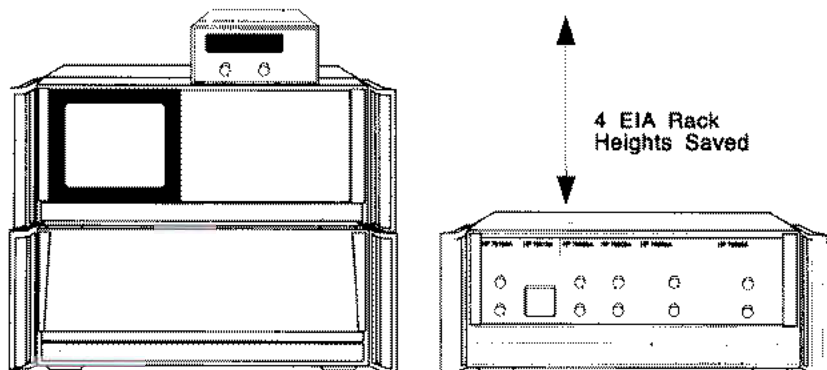

With no display, the HP 71210C Option 200 and an HP 70100A power meter use half the rack space of an HP 8566B spectrum analyzer and power meter.

MMS Overview

Designed for performance

EMC at microwave frequencies

Good electromagnetic compatibility (EMC) is critical to achieve high performance in instrumentation. It is particularly important at microwave frequencies, where systems include both high power sources and sensitive spectrum analyzers measuring low level signals. The system MMS mainframe meets VDE B (0871); FTZ 526, 527/1979; FCC Part 15 Subpart J, Class B; and MIL-STD 461B CS01, 02, 06 and RE02 conducted and radiated limits. In addition, the close proximity of modules also requires that close-field EMC levels be characterized to ensure system integrity. HP modules pass a total of 18 standard tests.

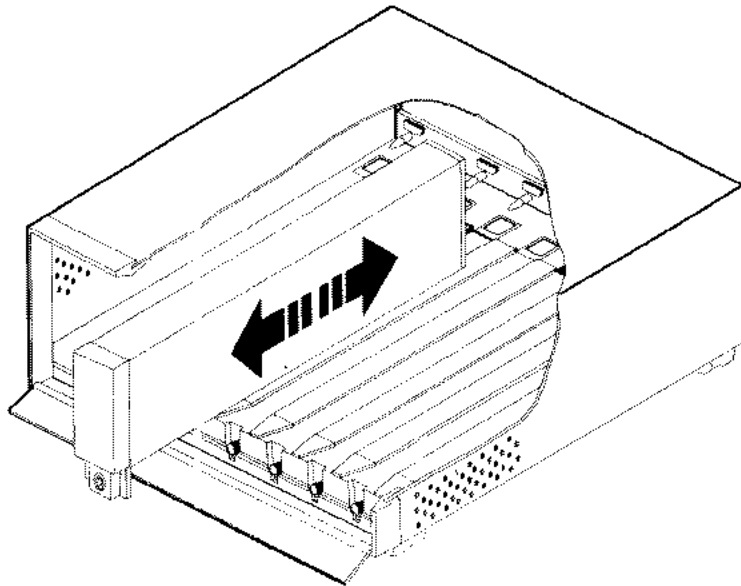

MMS features ensure good EMC characteristics at high frequencies.

The mainframe provides the environment that allows modules to comply with MIL-STD 461 radiated and conducted limits. MMS modules are housed in shielded enclosures. When a module is inserted into the mainframe, the rear connector is completely enclosed by metal to reduce radiated emissions and susceptibility.

The module is grounded to the mainframe with special grounding points to reduce emissions. The 40 kHz switched power supply reduces module-to-module interference.

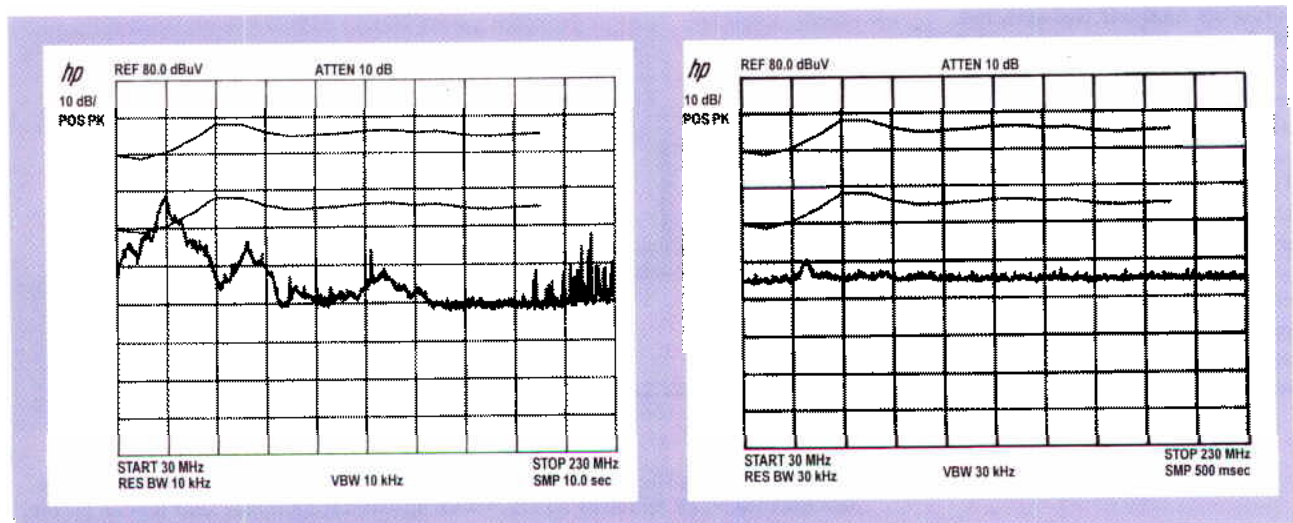

HP System II

MMS

MMS Overview

Rugged performance

Many systems require rugged performance, but not all operating environments are as benign as the typical office space. The MMS platform is prepared for this. Its mechanical design allows compliance with vibration and shock requirements of MIL-T-28800E Type III Class 3 for most MMS systems. (A few exceptions meet Class 5 only.)

Modularity provides many challenges for ruggedness. But the MMS module is held firmly in place with a V-groove at the front and a guide pin on the rear. The blackplane design completely protects all connector pins from damage without requiring special care during module installation. (When the module is not installed, connector pins are completely protected against static discharge.) A two-position latching system firmly holds the module in place. Although significant torque is not required to install a module, the latching system will handle over 4.5 newton-meters (40 inch-pounds). The complete module system is designed for over 500 insertion cycles.

Compatibility with VXIbus

Combining MMS with other instruments based on open standards lets you configure systems with optimal price and performance. For example, you can choose MMS for RF and microwave test requirements and HP VXI for low-frequency analog and digital needs.

HP MMS and VXIbus were designed for compatibility in systems. They share a common I/O interface (IEEE-488), yet each has a high speed internal bus. Both systems can be tied to a common 10 MHz clock reference and both use common trigger signal levels.

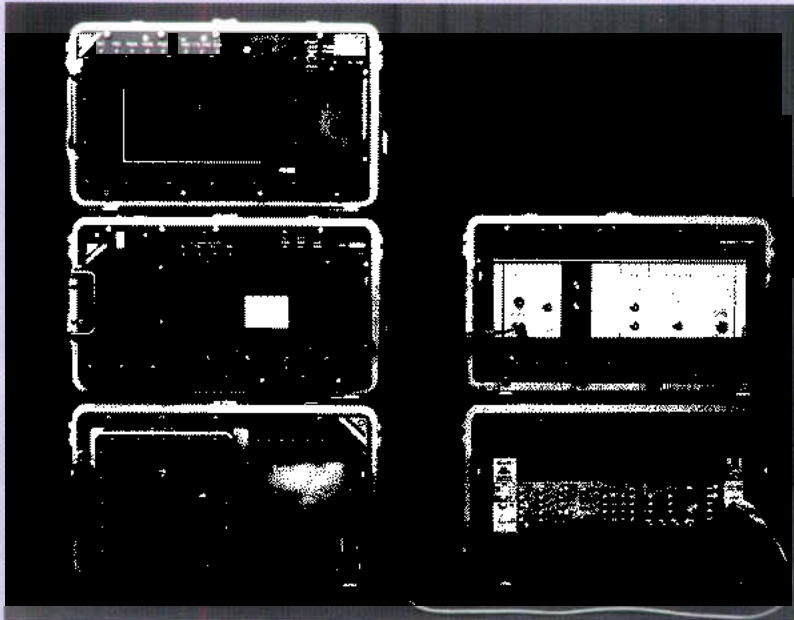

Electronics & Space Corp. builds the RFMETS (Radio Frequency Mobile Electronics Test Set) for the U.S. Air Force. The RFMETS is a rugged, readily deployable tester that implements a dynamic, real-time, functional test architecture. MMS was chosen because of its ruggedness, size, and modularity.

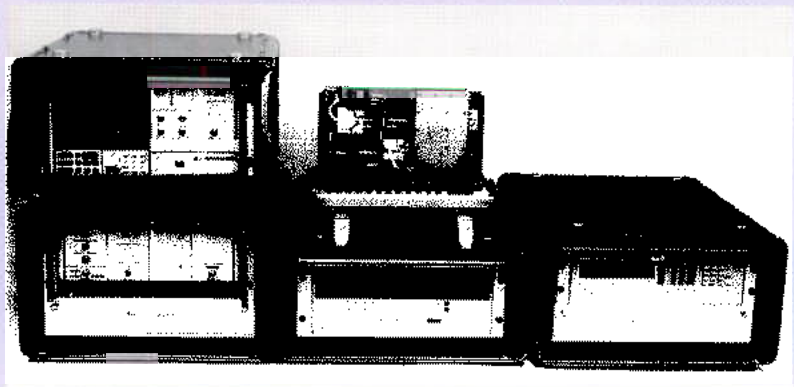

This Westinghouse Down-sized Automatic Test Equipment takes advantage of both standards, using VXI digital and analog instruments and MMS RF instruments.

MMS Overview

Versatile display

The display is an important component of an automated system. It saves time when you are developing measurement algorithms or debugging software because it gives instant feedback about what the instrument is doing. The display is used in manufacturing or depot tests that require real-time measurements, such as those used to manually adjust a filter.

With just a couple of keystrokes, the display can be assigned to any instrument in the system. It then takes on the personality of that instrument. You operate the instrument with 14 easy-to-use softkeys, and you can view measurement data just as you would on a standalone instrument. In fact, you can view measurement data from up to four different instruments while controlling one, all simultaneously! This is helpful for verifying system performance when the system is being set up, upgraded, modified, or tested.

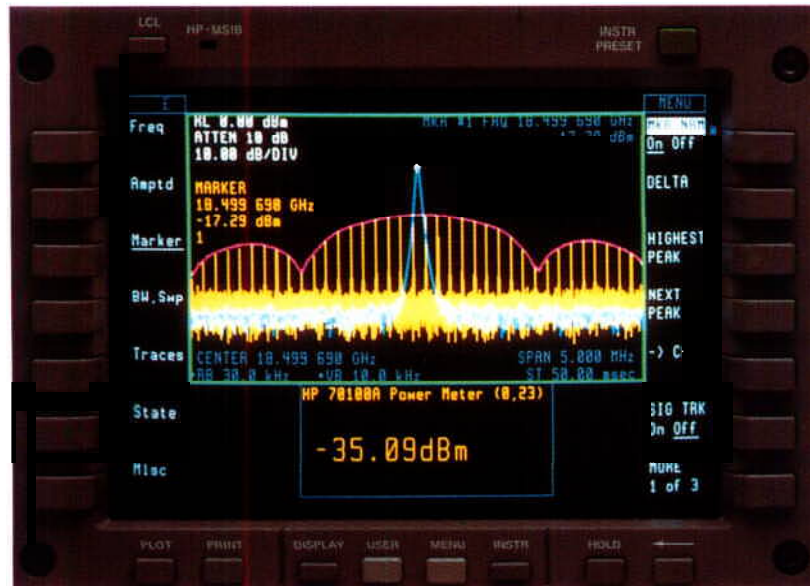

The convenient central display has 14 easy-to-use softkeys.

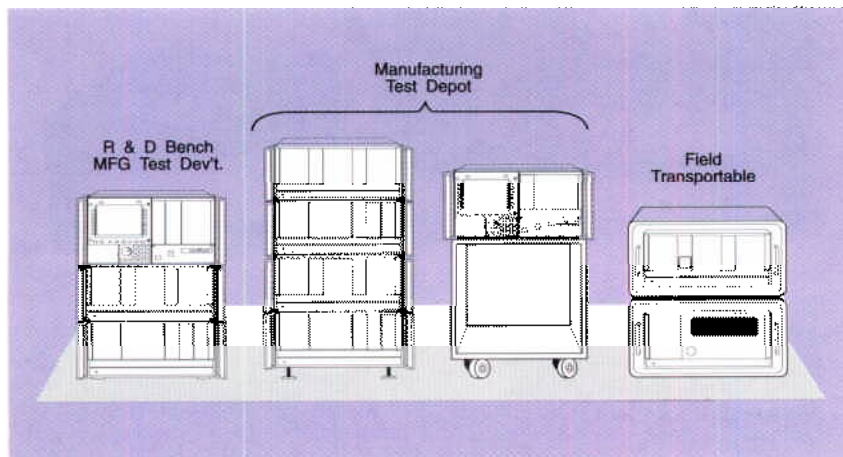

Include the MMS display in your system only when you need it.

Optional display

You can choose to exclude the display from the final test system; it is still available if you need it later for system upgrades or for troubleshooting a device under test. Simply connect the display into the system with the MSIB cable and you have full access to all the display capability. Disconnect the display from the system when you're finished and move it to another system.

MMS Overview

Operation from a distance

MMS allows instruments to be separated by large distances and operated from one or more locations. Operation from a distance is especially important when instruments must be located in environments that are not suited for an operator, such as atop a radio tower or in a test chamber with high electromagnetic fields.

The illustration shows an MMS system monitoring several satellite earth ground stations with a distance of up to 1.0 km between each station. A central display allows an operator to monitor any one of the satellite stations from a convenient location. Up to four stations can be simultaneously monitored with this one display. It takes just a couple of keystrokes to quickly switch and monitor four other stations. In each station a local display also can be used to monitor the local station or any other station.

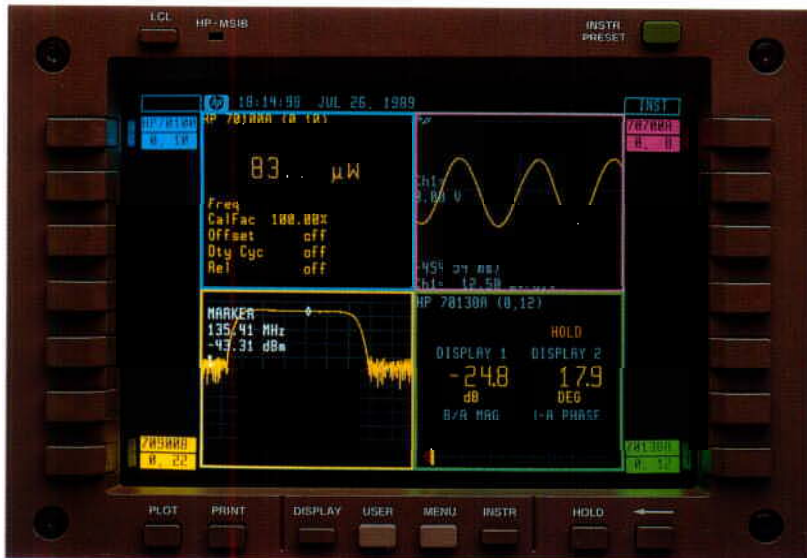

Using the MMS display, you can measure four instruments simultaneously.

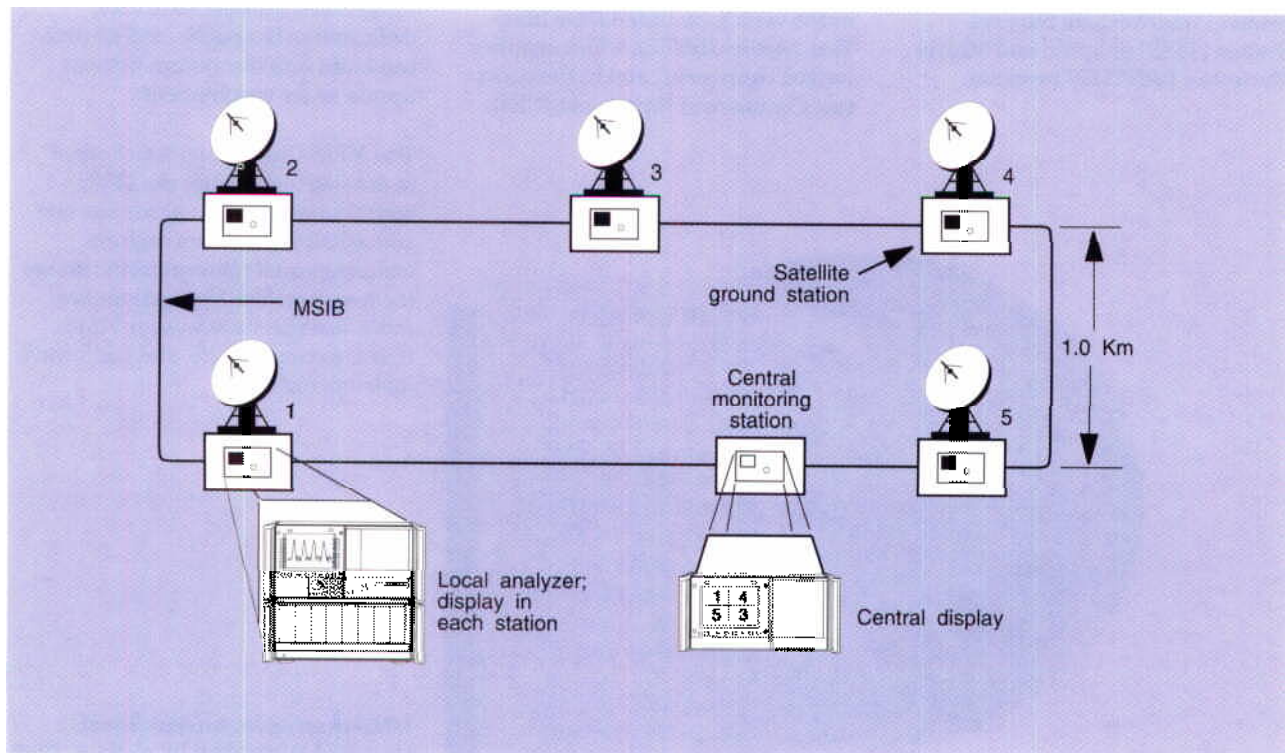

Operate several instruments over long distances using a central, local display.

MMS Overview

Widespread acceptance

MMS is accepted worldwide in both commercial and defense industries. More than 7,000 MMS mainframes have been sold—about half of them outside the U.S.—and over 75% of them to commercial customers. In the last five years MMS also has been chosen for nearly every major U.S. Defense ATE program containing RF and microwave instrumentation.

MMS in defense ATE

Size, performance, ruggedness, and breadth of product offering make MMS ideal for defense ATE applications. It is used in a number of U.S. DoD programs. MMS is the central architecture for the RF suite portions of the U.S. Navy Consolidated Automated Support System (CASS) program, and it is included in the core CASS system. A MATE module for USAF programs is available for spectrum analyzer systems. It is used in the USAF TEWS (Tactical Electronic Warfare System) Intermediate Support System (TISS) program and Martin Marietta's LANTIRN program.

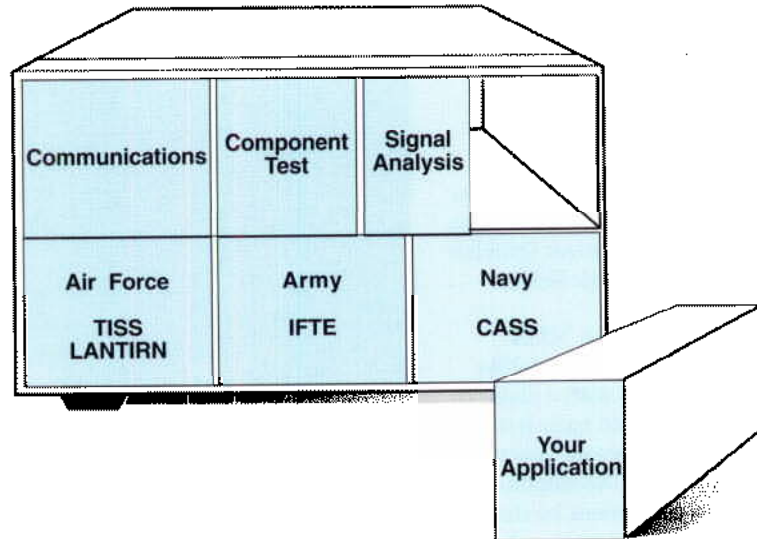

MMS: RF-to-lightwave instrumentation for commercial and defense applications

MMS is also deployed in both the military and commercial versions of the U.S. Army Integrated Family of Test Equipment (IFTE) program: in the vehicle-mounted Base Shop Test Facility (BSTF), which requires rugged equipment, and in the depot test Commercial Equivalent (CEE).

An open standard

MMS is an open standard worldwide, controlled by a consortium of test equipment manufacturers and system integrators. Patents have been dedicated to the public, and anyone can build into the system without license or fee requirements.

The MMS Consortium was formed to develop and control the MMS specification. Each member has one vote on all Consortium matters, ensuring equal representation across the industry. The Consortium has published specifications for MMS that is optimal for RF and microwave instrumentation.



Member companies

Comstron Division of
Aeroflex Laboratories, Inc.
GEC-Marconi Avionics Ltd.
Hewlett-Packard Company
Lockheed Martin Information
Systems Company
Martin Communications Pty. Ltd.
Microsource, Inc.
Northrop Grumman Corp.
Tern Technology, Inc.

Associates

Advanced Manufacturing
& Development
Hamilton Software, Inc.
Packard-Hughes Interconnect

MMS is an open, international standard controlled by a consortium of industry members.

Configuration Example: Aerospace/Defense ATE Systems

The modular measurement system is an industry standard used successfully in many large aerospace/defense programs.



Official US Navy photo

IFTE

Northrop Grumman Corporation has provided MMS products to the U.S. Army as a part of the Integrated Family of Test Equipment (IFTE) program. MMS is a part of IFTE's intermediate, depot, and commercial equivalent development systems. Instrument performance and ease of support were key factors in the decision to incorporate MMS.

TISS

McDonnell-Douglas and Honeywell, Inc., have provided MMS to the U.S. Air Force for the TEWS (Tactical Electronic Warfare System) Intermediate Support System (TISS). The open architecture of MMS allowed a third party, Tern Technology, to design and produce a key component of the system, a radar receiver module, that was not commercially available.

CASS

The Automated Systems Department of Lockheed Martin, prime contractor for the U.S. Navy's Consolidated Automated Support System (CASS), selected MMS for the CASS RF suite of instrumentation. CASS meets the Navy's requirement for a test system capable of supporting and maintaining any existing or future measurement scenario. Modularity gives the system greater test compatibility, lower price, more logistic flexibility, and the capability to insert new technology to accommodate future needs.

LANTIRN

Modular measurement system equipment is used in the MATE-compatible support system for the Low Altitude Navigation and Targeting Infrared Ranging System for Night (LANTIRN) that Lockheed Martin Information Systems Company developed and supplied to the U.S. Air Force.

Configuration Example: Satellite Test System

Satellite communications payload test system

A family of satellite payload test systems meet the testing requirements for communication satellite payloads in a manufacturing environment. The systems are designed to maximize the use of standard test equipment, offering the maximum test capability at a minimum cost.

Each system is custom-designed for the specific testing requirements of a given satellite type and manufacturer's process. The system includes a custom interface panel with supporting signal routing and conditioning hardware that simplifies connection to the payload and provides for system calibration while maintaining measurement integrity. The HP 70611A switch driver is used to control the interface. This small, one-slot switch/attenuator driver provides control of even the most complex switches. Its MMS user interface allows easy labeling of each signal routing pattern, which simplifies manual operation.

The system shown here is for testing analog transparent payloads. Many measurements have been enhanced by using the wide bandwidth capability of the HP 71910A receiver with its analog I/Q demodulated outputs connected to the HP 89410A vector signal analyzer (VSA). The VSA processes the receiver IF using phase information to measure group delay, AM to PM conversion, and so forth.

Throughput requirements called for a dual-channel test system (except for two-tone tests), which increased the amount of equipment required for the system. However, the manufacturing process required a mobile tester that could be moved along with the satellite payload as it progressed through various test stages. Thus a single-rack solution was most desirable, and the need to combine dual channels in



a single rack posed a significant challenge. In designing this system, HP met the challenge by taking advantage of the comparatively smaller size of MMS.

High performance instruments can lose their competitive edge through degradation from the systemization process. Degradation can arise from interference between instruments, from cable losses, or from the interactions of long cabling. At microwave frequencies, the degradation can increase. In this satellite payload test system, the excellent EMI performance of MMS ensured the integrity of the system design against interference problems. The modularity of MMS allowed concentration of microwave modules near the interface panel, minimizing the effects of RF cabling.

System configuration

An HP sales representative can help you configure the best solution for your specific application. HP's broad base of MMS offerings includes off-the-shelf modules, application-specific custom switch matrixes, application software, distributed processing, and network techniques.

Dual-channel test station for a transparent communication satellite payload

In the photograph of the test station, the custom interface matrix is located at the top of the taller rack. Immediately below are two HP 70340A microwave sources, two HP 70620B preamplifiers, and the microwave-related modules for two HP 71910A receivers. (The two local oscillators are located in the display mainframe. The other modules are arranged as one channel per mainframe.) The receiver IF sections are located at the bottom of the rack above the four HP 70100A power meter modules. Located above and connected to the IF sections are the two HP 89410A vector signal analyzers for receiver IF signal processing.

The shorter rack is a calibration cart used to provide remote calibration through the long cables that connect to the unit under test (UUT).

Configuration Example: Direction-Finding Receiver

Hardware block diagram of a direction-finding receiver developed by ARGOSystems

This MMS-based RF and microwave scanning direction-finding receiver system combines standard MMS products, HP custom engineered modules, and the system designer's hardware and software to offer a commercially available system that met the goals of competitive cost, lower development time, high performance, ease of support, and flexibility of configuration. The system was envisioned by ARGOSystems, Inc., of Sunnyvale, CA, as a development platform for custom receivers and evaluation of new designs.

Competitive cost

The availability of standard, off-the-shelf modular components provided the performance needed at a minimal cost, and allowed ARGOSystems to leverage the efforts of its engineering staff. Engineers did not expend effort on the analog or control sections of the system. They were able to focus primarily on the digital signal processing capability that is the core of their contribution.

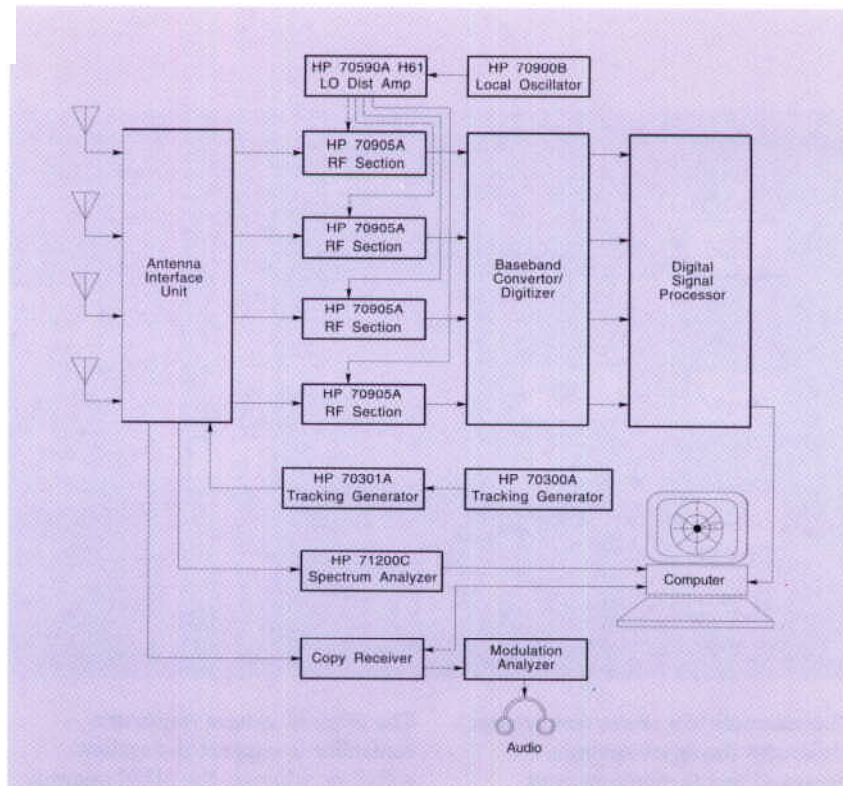

Superior time to market

Available standard modules as well as module development products assisted both HP and ARGOSystems in the custom part of the design, and thus allowed the system to be integrated in less time than a full custom receiver.

High performance off the shelf

The superior amplitude and phase stability of the MMS RF and IF modules allow state-of-the-art angle of arrival (AoA) performance with standard, readily available modules.

Flexible through modularity

Spatial resolution of an interferometer-based direction-finding system is partially a function of the number of elements (channels). A key feature of this system is the ability to readily add channels, thereby increasing spatial resolution performance.

Support worldwide

All HP manufactured modules are designed and built to our high quality standards, documented fully, and supported by HP service centers worldwide.

System configuration

An HP sales representative can help MMS hardware for your specific receiver application.

Configuration Example: Mixer Test System

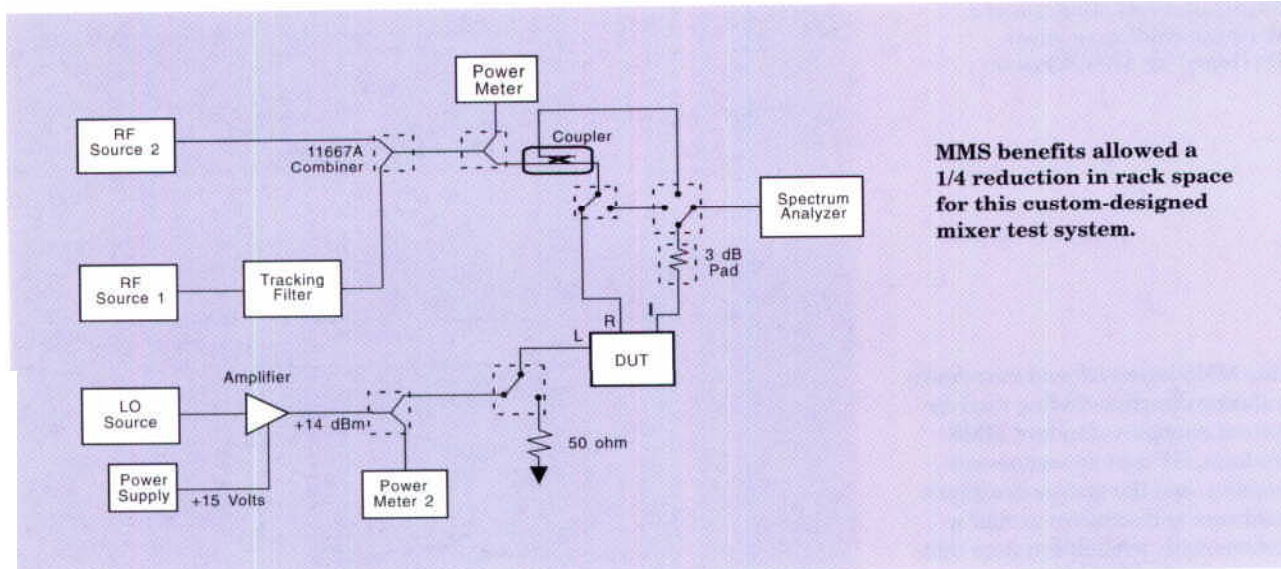

MMS benefits allowed a 1/4 reduction in rack space for this custom-designed mixer test system.

This example of a mixer test system illustrates the space savings, improved test throughput, and reduced cost you can achieve by exploiting the MMS. The example shows an upgraded mixer test station currently used on one of two full, five-foot rack cabinets. It used HP 8340B synthesizers to provide mixer stimulus and an HP 8566B spectrum analyzer to measure mixer response.

Higher performance in a downsized package

Generally, the MMS requires less rack space to implement functionality. In this case, the entire MMS system takes one fourth the rack space of the rack-and-stack version. For example, the HP 8340Bs are full rack width instruments. The MMS system uses an HP 70300A RF tracking generator combined with an HP 70900B local oscillator to provide an offset signal stimulus in one half the rack space.

The original system required a controller to support the system software, whereas the MMS upgrade uses the LO microprocessor to run a downloaded version of the same code without requiring a computer.

Enhanced throughput

System test throughput has been increased by using a tracking generator/spectrum analyzer combination rather than the synthesizer/spectrum analyzer combination used before. The concept required the synthesizer and spectrum analyzer to tune to each frequency point, lock, and then measure. If the test program required many frequency points across the band of interest to fully characterize the mixer, testing was slow. The tracking generator/spectrum analyzer combination has decreased the test time.

Lower hardware cost

Because the MMS eliminates redundant electronics, significant cost savings have been realized. The total price of the MMS version is approximately 80% of the earlier rack-and-stack system.

System configuration

An HP sales representative can help you configure the best solution for your specific application. HP's broad base of MMS offerings include

- off-the-shelf modules
- application-specific custom switch matrixes
- application software, distributed processing, data storage and retrieval, and networking techniques.

Instruments in the MMS Family

Instruments

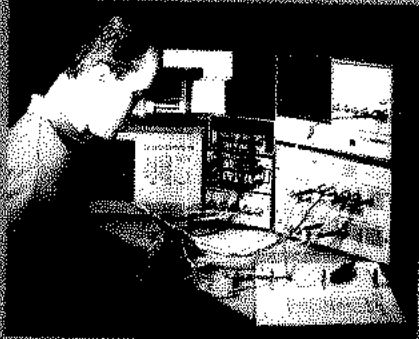

HP 71000 series
gigabit error ratio tester

HP 71501C
jitter analyzer

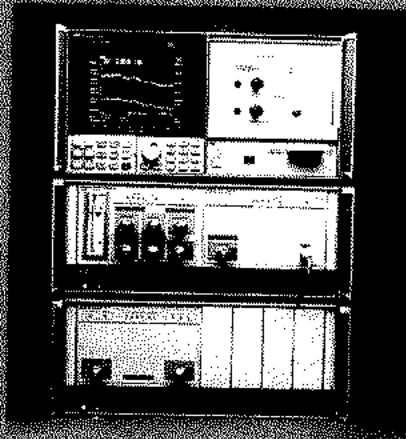

Attenuator/switch driver
and interface modules
HP 70611A, 70612A/C, and
70613A/C

SECTION CONTENTS

15 Sources

- 15 Microwave Synthesizer
- 18 Microwave Source

20 Signal Analyzers

- 20 Power Meter
- 23 Digital Multimeter
- 25 Universal Counter
- 26 Digitizer
- 29 Digitizing Oscilloscope
- 31 Microwave Transition Analyzer
- 35 Microwave Downconverter
- 37 Wide Bandwidth Receiver

44 Spectrum Analyzers

- 44 HP 70000 Series Overview
- 47 RF Spectrum Analyzer
- 51 Microwave Spectrum Analyzers
- 65 Fundamentally Mixed Microwave Spectrum Analyzer
- 69 Upgrade Kits
- 75 Preamplifiers
- 80 Noise-Figure Measurement Personality
- 82 Tracking Generator Systems
- 87 Millimeter Spectrum Analysis

90 Lightwave and Communications

- 90 Custom Engineering
- 92 Digital Radio Analyzer
- 93 Lightwave Signal Analyzers and Accessories
- 97 Lightwave Section
- 99 Fiber-Optic Interferometer
- 100 Optical Spectrum Analyzers
- 108 Jitter Analyzer
- 112 Gigabit Error Performance Analyzers

Instruments

This section describes the wide variety of MMS instruments. Each fully specified, individual instrument provides high performance capability in either single-module or multiple-module packages.

Single-module instruments require a mainframe (HP 70001A or 70004A) for power, cooling, EMC protection, and communication bus. For manual operation, a display (HP 70004A, 70205A, or 70207B) is required. Any module can be located in any slot.

For R&D or manufacturing, you can use these instruments alone, or configure them into multiple-instrument workstations. For automated manufacturing or integrated solutions, you can control the workstations via computer over the HP-IB. For large or complex tasks, you can combine MMS instruments with VXIbus or other instrument platforms.

Single-Module Instruments

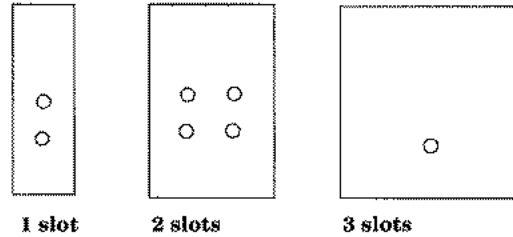

Multiple-Module Instrument Systems

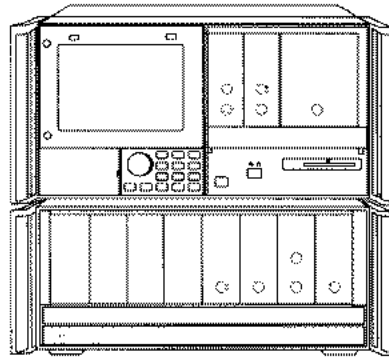

Standard systems may have several slots available. You can easily add other modules.

Multiple-Instrument Workstations

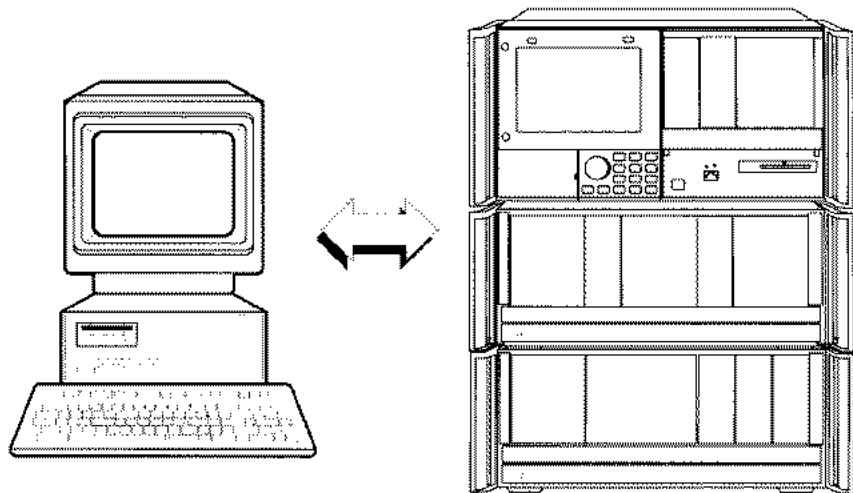

Combine systems and modules by plugging modules into empty slots. Add mainframes and displays as needed.

Sources

Microwave Synthesizer

HP 70340A/70341A

HP 70340A SIGNAL GENERATOR
1-20GHz

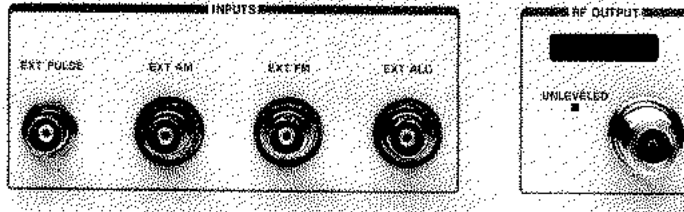
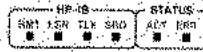

1 to 20 GHz

Synthesized signal generator

Add-on module provides 10 MHz to 1 GHz extension

+13 to -90 dBm amplitude range

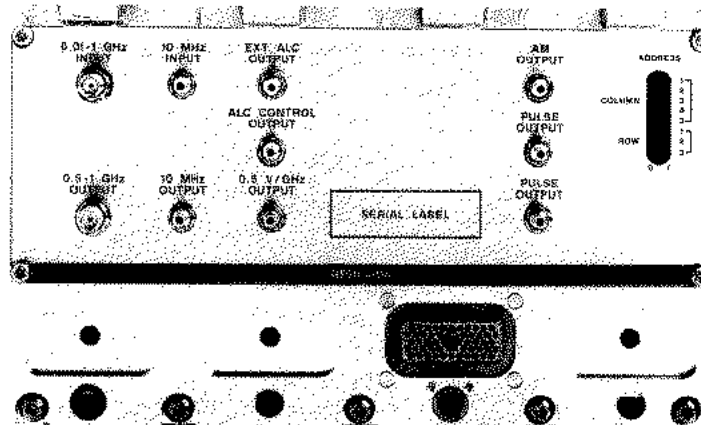

The HP 70340A modular signal generator satisfies the demands of tomorrow's ATE for a smaller, lighter, high performance signal source. Combining superior reliability, excellent modulation, a reduced footprint, and modular flexibility, the HP 70340A has all the performance of traditional rack-and-stack signal sources in half the rack space---without any loss of capability.

You can test receivers and subsystems from 1 to 20 GHz with confidence, knowing that even at full power (typically > +14 dBm), the HP 70340A delivers superior signal purity. Harmonics are suppressed above 55 dBc while other spurious signals are reduced below -60 dBc. Sub-harmonic signals are completely eliminated. Excellent output power accuracy (± 2 dB) and flatness (± 0.5 dB)

are maintained across the entire > 100 dB dynamic range and the full frequency range of the HP 70340A, even at temperature extremes.

Flexible for many uses

The HP 70340A combines superior internal level accuracy and flatness with the flexibility of User Level Correction. This feature allows you to calibrate and program the signal generator output for automatic leveled power at distant test ports. Four level correction tables can be stored in memory for quick access as the system is reconfigured for different DUTs or test scenarios.

You can generate complex, real-world signals using the pulse, FM, and logarithmic AM modulations. Simulate modern radars and other EW signals with the fast (< 10 ns rise

and fall), high fidelity pulse modulation. Option 1E2 provides an internal multimode pulse modulation source with variable pulse rates, widths, and delays. A new pulse modulator provides excellent pulse flatness and level accuracy while minimizing overshoot, ringing, and video feedthrough.

The high index FM provides extra capability for testing telemetry and other wide deviation systems. Simultaneous use of log AM and pulse modulation allows simulation of scanning emitters in EW simulations. Log AM can also be used to sweep output power accurately and linearly for use in amplitude compression tests. All modulations are completely independent, enabling simultaneous use without degradation of any performance parameter.

Sources

Microwave Synthesizer

HP 70340A/70341A

Frequency extension module

The HP 70341A frequency extension module brings microwave performance to RF and IF testing. The HP 70340A's powerful modulation, low harmonics, and zero subharmonics are made available at frequencies from 10 MHz to 1 GHz with higher output power and lower phase noise. Digital frequency dividers lower phase noise by 6 dB per octave as the frequency is reduced, making the HP 70340A/70341A combination a powerful in-channel receiver test stimulus. Elimination of down-conversion mixers reduces broadband noise, and switched low pass filters generate fast, accurate pulse modulation. Logarithmic AM provides capability not found in conventional RF signal sources. You get full 10 MHz to 20 GHz coverage from a single RF output connector without sacrificing level accuracy or flatness. The HP 70341A is slaved to the HP 70340A so that all system software runs on the combination without change.

The HP 70340A/70341A are ideal for modern ATE systems. Their small size, light weight, excellent reliability, and high performance make them especially attractive for downsized and portable ATE. Their high MTBF (> 20,000 hours), extended calibration cycle (2 years), and low calibration time (< 6 hours for full cal) reduce system downtime in high throughput commercial ATE. A wide selection of options adds extra capability to your system when you need it and saves money. SCPI programming assures that system software designed around the HP 70340A/70341A will remain compatible and upgradeable for years to come.

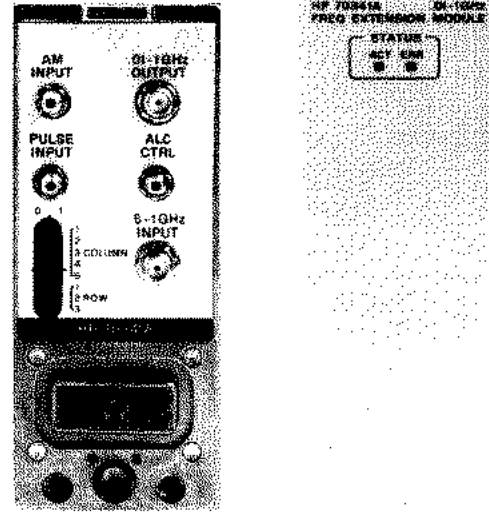

Specifications

For complete specifications refer to the HP 70340A/70341A data sheet (part number 5091-4649E).

Frequency

Frequency range 1 to 20 GHz; 10 MHz to 20 GHz with HP 70341A

Frequency resolution 1 kHz; 1 Hz with Option 1E8

Leveled output power (with Option 1E1 installed)

- 10 MHz to 1 GHz +13 to -90 dBm
- 1 GHz to 18 GHz +10 to -90 dBm
- 18 GHz to 20 GHz +8 to -90 dBm

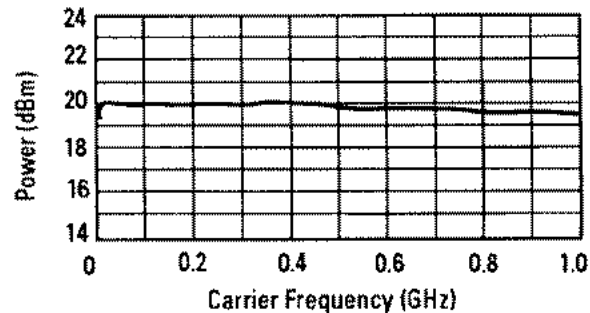
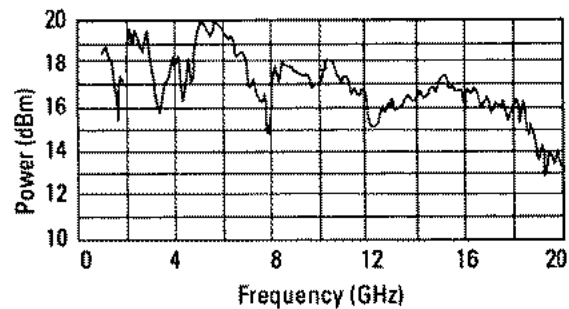

Sources

Microwave Synthesizer

HP 70340A/70341A

(Frequency continued)

Resolution	0.01 dB	
Accuracy	±2 dB (all frequencies, power levels and temperatures)	
Flatness	±0.5 dB	
Harmonics	< -55 dBc	
Sub-harmonics	None	
Non-harmonic spurious	-60 dBc	
SSB phase noise (10 kHz offset)	500 MHz	-103 dBc/Hz
	2 GHz	-91 dBc/Hz
	18 GHz	-73 dBc/Hz

External pulse modulation

On/off ratio	> 80 dB
Minimum pulse width	< 25 ns, 500 MHz to 20 GHz < 100 ns, 64 to 500 MHz < 1 ms, 10 to 64 MHz
Maximum rise/fall time	< 10 ns, 1 to 20 GHz < 15 ns, 500 to 1000 MHz < 35 ns, 128 to 500 MHz

External frequency modulation

Rates	1 kHz to > 1 MHz
Maximum deviation	10 MHz
Maximum modulation index	> 300

External amplitude modulation

Type	Logarithmic AM
Depth	0 to 60 dBc
Sensitivity	10 dB/V
Step response	< 5 μs for 50 dB step

Weight	< 9 kg (20 lb) HP 70340A < 4 kg (10 lb) HP 70341A
Size	4 slot MMS module HP 70340A 1 slot wide MMS module HP 70341A

Ordering Information

HP 70340A modular signal generator

- Option 1E1** add output step attenuator
- Option 1E2** add internal pulse modulation source
- Option 1E8** add 1 Hz frequency resolution
- Option 1E9** 3.5 mm RF output connector
- Option 0B2** extra operating manual
- Option 0B3** service manuals

HP 70341A frequency extension module

- Option 0B2** extra operating manual
- Option 0B3** service manuals
- Option W30** two additional years of return-to-HP warranty (3 years total)

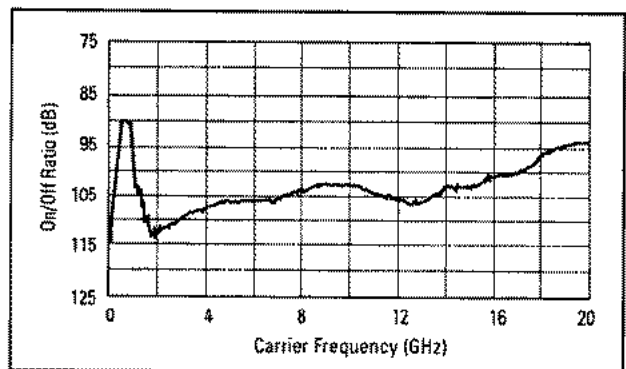
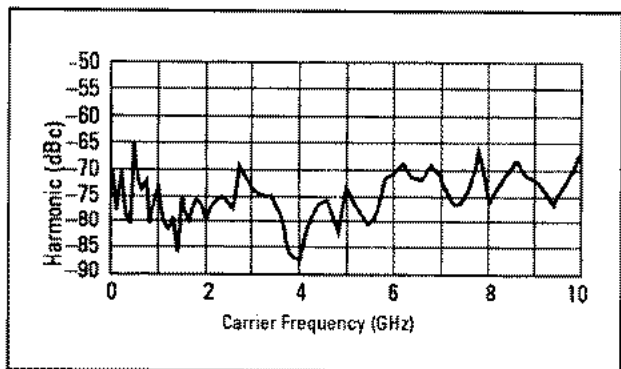
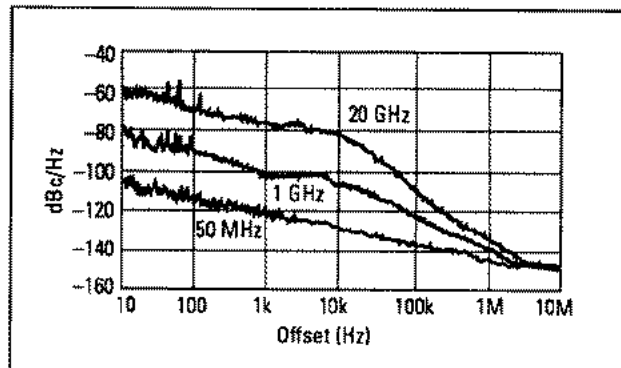
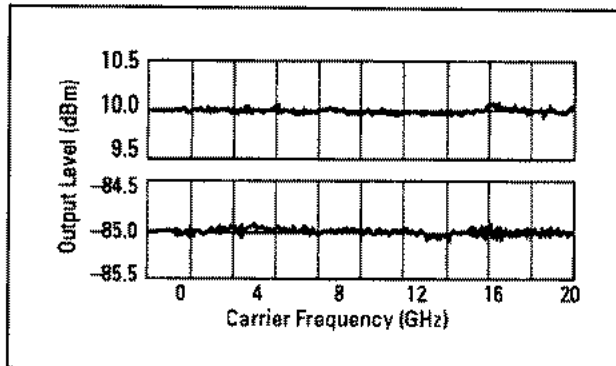

Sources

Microwave Source

HP 71708A/70428A

Microwave source with excellent phase noise

Output frequency range 2.4 to 25.8 GHz

Frequency resolution of 600 MHz

Optional frequency resolution of 0.1 Hz

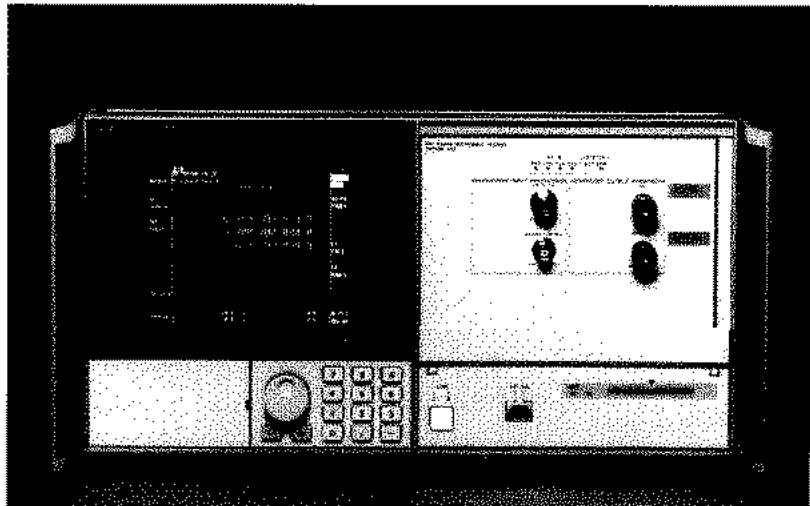

HP 71708A microwave source
The HP 71708A microwave source makes an excellent substitute LO for your radar system, phase noise measurement system, or test source for microwave receiver testing. It provides the lowest AM phase noise of any commercially available microwave source and provides up to +16 dBm of output power. The standard HP 71708A has a frequency resolution of 600 MHz. If finer frequency resolution is required, Option 002 and an HP 8662A synthesized signal generator can be added to provide resolution of 0.1 Hz.

If four slots are available in your MMS system, microwave source capability can be added with the HP 70428A module.

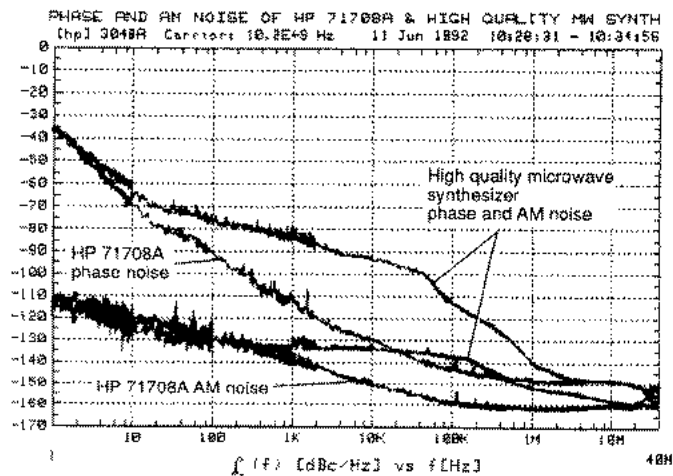

Phase noise comparison of HP 71708A vs. microwave synthesizer

Sources

Microwave Source

HP 71708A/70428A

Specifications

RF output

Frequency range	2.4 to 25.8 GHz, std. 2.4 to 26.5 GHz, Option 002
Frequency resolution	600 MHz, std. 0.1 Hz, Option 002

Output power

2.4 to 6.6 GHz	0 to +16 dBm
7.2 to 25.8 GHz	0 to +10 dBm

Spectral purity

Phase noise performance varies with tuning sensitivity. The table below shows the phase noise performance for a tuning sensitivity of 0.05 ppm/volt.

Supplemental characteristics

Tuning sensitivity	0.05 ppm/volt, 1 ppm/volt, 20 ppm/volt
Tuning port voltage range	± 5 volts
Tuning port input impedance	2 k Ω

General

Environmental temperature	Operational, 0° to +55° C; storage, -40° to +75° C
Humidity	Operational, 0 to 95% relative humidity at 45° C
Calibration interval	One year recommended
Power	HP 71708A: 260 watts maximum HP 70428A: 80 watts maximum with Option 002
Weight	HP 71708A: Std 26.8 kg (58.9 lb); with Option 002 29.3 kg (64.5 lb) HP 70428A: Std 7.4 kg (16.1 lb); with Option 002 9.9 kg (21.7 lb)
Size	HP 71708A: 222 mm H x 425.4 mm W x 526 mm D (8.74" x 16.75" x 20.7") HP 70428A: 4-slot width

Ordering Information

HP 71708A microwave source
Includes HP 70428A microwave
downconverter module and
HP 70004A color display/
mainframe

Option 002 0.1 Hz frequency
resolution (requires HP 8662A
synthesized signal generator)

HP 70428A microwave source module

Additional Information

Technical datasheet

HP 71708A/70428A
part no. 5091-4500EUS

Product Overview

HP E5500 Series
Phase Noise Measurement Solutions
part no. 5965-7590E

		1	10	100	1k	10k	100k	> 1M
2.4 to 3.0 GHz	Typ.	-50	-80	-100	-128	-138	-148	-152
	Spec.	-45	-75	-95	-123	-133	-143	-147
3.0 to 4.2 GHz	Typ.	-47	-77	-97	-125	-136	-146	-150
	Spec.	-42	-72	-92	-120	-131	-141	-145
4.2 to 6.0 GHz	Typ.	-44	-74	-94	-122	-134	-144	-148
	Spec.	-39	-69	-89	-117	-129	-139	-143
6.0 to 7.8 GHz	Typ.	-42	-72	-92	-120	-132	-143	-147
	Spec.	-37	-67	-87	-115	-127	-138	-142
7.8 to 10.2 GHz	Typ.	-40	-70	-90	-118	-130	-141	-145
	Spec.	-35	-65	-85	-113	-125	-136	-140
10.2 to 12.6 GHz	Typ.	-38	-68	-88	-116	-128	-140	-143
	Spec.	-33	-63	-83	-111	-123	-135	-138
12.6 to 18.0 GHz	Typ.	-35	-65	-85	-113	-125	-137	-140
	Spec.	-30	-60	-80	-106	-120	-132	-135
18.0 to 25.8 GHz	Typ.	-32	-62	-82	-110	-122	-134	-136
	Spec.	-27	-57	-77	-105	-117	-129	-131

¹ All levels above -30 are 30 dB below S(f) expressed in dB with respect to 1 rad²/Hz

Phase noise performance for a tuning sensitivity of 0.05 ppm/volt

Signal Analyzers

Power Meter

HP 70100A

± 0.02 dB or $\pm 0.5\%$ accuracy

100 kHz to 50 GHz

-70 to +44 dBm

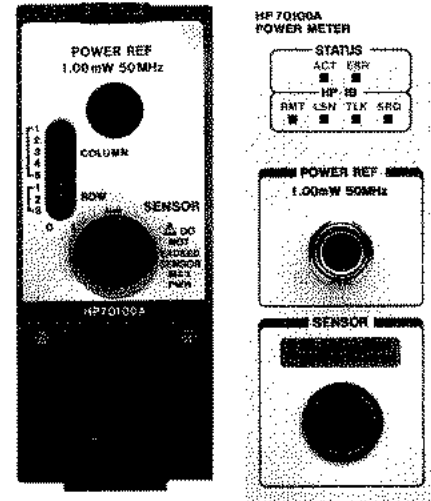

The HP 70100A is a single-channel, one-slot power meter module with features and capability similar to an HP 437B power meter.

Exceptional meter linearity and low sensor SWR combine to give you outstanding accuracy for demanding measurements. With instrument accuracy specified as $\pm 0.5\%$ in linear mode and ± 0.02 dB in logarithmic mode, instrument uncertainty becomes a negligible part of total measurement error.

Features include automatic calibration and zeroing, frequency and calibration factor entry, selectable resolution, duty cycle, manual range setting, and save and recall of meter settings.

The HP 70100A is compatible with the HP 8480 series of power sensors. It is also compatible via the HP-IB with programs written for the HP 438A power meter¹.

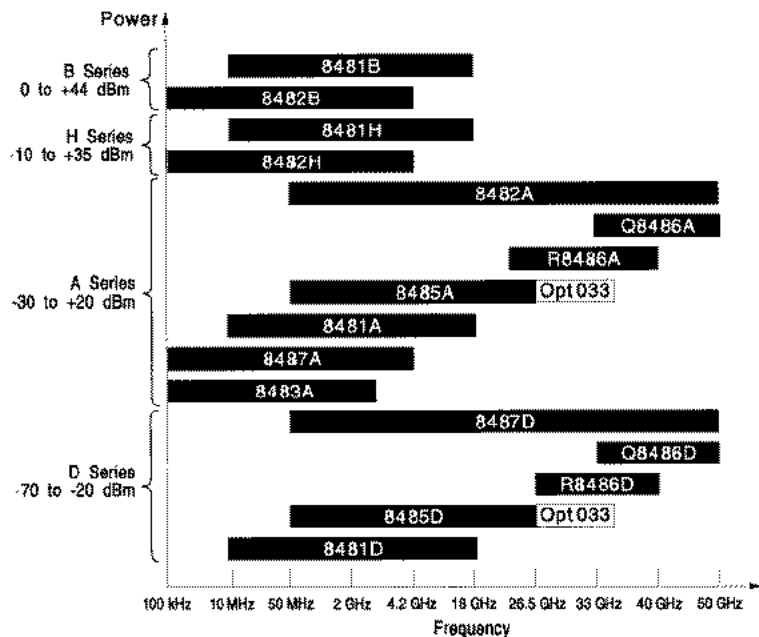

¹ The HP 70100A does not respond to software commands involving two or more channels (such as the A/B command "AR"). Also, one HP 70100A cannot control another HP 70100A for dual-channel capability. You can, however, get dual-channel capability from a computer or by controlling two HP 70100As with a DLP (downloadable program) from your modular spectrum analyzer.

Signal Analyzers

Power Meter

HP 70100A

Specifications

Specifications describe the instrument's warranted performance over the 0° to +55° C temperature range. Supplemental characteristics are intended to provide information useful in applying the instrument by giving typical, but non-warranted, performance standard.

Power meter specifications

Frequency	100 kHz to 50 GHz, sensor dependent
Power range	-70 to +44 dBm (100 pW to 25 W), sensor dependent
Power sensors	Compatible with all HP 8480 series sensors
Dynamic range	50 dB in 10 dB steps
Display units	W, dBm (absolute); %, dB (relative)
Accuracy instrumentation	±0.02 dB or ±0.5%
In relative mode	±0.02 dB or ±0.5% within calibration range; ±0.04 dB or ±1% outside
Zero set²	±0.5% of full scale on most sensitive range. Divide percentage by a factor 10 for each higher range, ±1 display count.
EMI	Radiated interference is within the requirements of MIL-STD-461B, Class A1c, RE02

Power meter characteristics

Meter noise (% of full scale, constant temperature, range 1, measured over one minute interval, two standard deviations)
Decrease noise by a factor of 10 for each higher range for all sensors and all filters

HP 8481/2/3/5A/6A/7A sensors

Averages	1	4	8	16	32	64	128	256	512	1024
Noise (%)	12	2.4	1.8	0.9	0.7	0.5	0.4	0.3	0.2	0.15

HP 8481/5/7D Sensors multiply noise levels by 4

HP R/Q8486D Sensors multiply noise levels by 6

Zero Drift of Sensors (% of full scale, 1 hour, at constant temperature after 24-hour warm up)

Divide percentage by 10 for each higher range,

HP 8481/2/3/5A/6A/7A: < 0.3% of full scale (range 1)

HP 8481D/5D/6D/7D: < 2.0% of full scale (range 1)

Settling time (0 to 99% settled readings over the bus)
Range HOLD, 10 dB decreasing power over step

Filter no.	0	1	2	3	4	5	6	7	8	9
Averages	1	4	8	16	32	64	128	256	512	1024
Settling time	0.03	0.13	0.25	1.0	1.4	2.2	3.7	6.9	14	27

Settling time vs. range and resolution (for auto filter mode)

	Res 1 (0.1 dB, 1% F.S.)	Res 2 (0.01 dB, 0.1% F.S.)	Res 3 (0.001 dB, 0.01% F.S.)
Highest 5	0.1	0.1	1.0
Power 4	0.1	0.1	1.4
3	0.1	0.15	2.2
Lowest 2	0.1	1.0	14.0
power 1	1.0	6.9	6.9

Default resolution (characteristic) of 0.01 dB, range HOLD, 10 dB decreasing power step

< 7.0 s, range 1

< 1.0 s, range 2

Measurement speed over HP-IB, free-running trigger: 40 readings per second, (characteristic)

Power reference specifications

Power output	1.00 mW. Factory set to ±0.7%, traceable to U.S. National Institute of Standards and Technology (NIST)
Accuracy	±1.2% worst case (±0.9% RSS) for one

Power meter functions

- Frequency:** Allows entry of test signal frequency for calibration factor selection
- Offset:** Allows power measurement to be offset by -99.99 to +99.99 dB
- Resolution:** Selectable resolution of 0.1, 0.01, and 0.001 dB in logarithmic mode; 1%, 0.1%, and 0.01% of full scale in linear mode
- Auto filter mode:** The meter automatically selects the required number of averages for the chosen range and resolution
- Averaging:** Selectable from 1 to 1024 readings (in powers of 2)
- Duty cycle:** Displays peak power representation of measured RMS power for rectangular pulses
- Limits:** Automatically displays "Over Limit" or "Under Limit" when the power measured is outside the limit boundaries
- Entry range:** -299.999 and +299.999 dBm
- Sensor tables:** Allows entry and editing of up to 10 frequency-vs.-cal factor sensor tables
- Save/recall states:** Saves and recalls 10 complete HP 70100A operating states

General

Module size	1 slot
Weight	1.9 kg (4.2 lb)
Literature	Application Note 64-1, Fundamentals of RF and Microwave Power Measurements, part number 5952-8178
Standard warranty	1 year
Recommended calibration cycle	1 year
HP 70004A display features used	Direct plot, direct print

Accessory provided

HP 11730A One 1.5-meter (5 ft) sensor cable

Ordering Information

- HP 70100A** power meter module
- Option 003** move reference oscillator from front to rear panel
- Option 004** delete sensor cable
- Option 005** delete reference oscillator
- Option 910** extra operating manual
- Option 915** service manual
- Option W30** two additional years of return-to-HP warranty (3 years total)

² If using the HP 8481D/5D/6D/7D Power Sensors: ±2% of full scale

Signal Analyzers

Power Meter

HP 70100A

HP 8480 Series Sensor Specifications

HP model	Frequency range	Maximum SWR	Power linearity ¹	Maximum power	Connector type	Weight
25 W sensors, 1 mW to 25W (0 to +44 dBm)						
8481B	10 MHz-18 GHz	10 MHz-2 GHz: 1.10 2-12.4 GHz: 1.18 12.4-18 GHz: 1.28	+35 to +44 dBm ±4%	0-35° C: 30 W avg 35-55° C: 25 W avg 0.01-5.8 GHz: 500 W pk 5.8-18 GHz: 125 W pk 500 W • μs per pulse	N(m)	Net 0.8 kg (1.75 lb) Shipping 1.5 kg (3.25 lb)
8482B	100 kHz-4.2 GHz	100 kHz-2 GHz: 1.10 2-4.2 GHz: 1.18	+35 to +44 dBm ±4%	0-35° C: 30 W avg 35-55° C: 25 W avg 0.01-5.8 GHz: 500 W pk 5.8-18 GHz: 125 W pk 500 W • μs per pulse	N(m)	Net 0.8 kg (1.75 lb) Shipping 1.5 kg (3.25 lb)
3 W sensors, 100 mW to 3W (-10 to +35 dBm)						
8481H	10 MHz-18 GHz	10 MHz-8 GHz: 1.2 08-12.4 GHz: 1.25 12.4-18 GHz: 1.30	+25 to +35 dBm ±5%	3.5 W avg, 100 W pk 100 W • μs per pulse	N(m)	Net 0.2 kg (0.38 lb) Shipping 0.5 kg (1 lb)
8482H	100 kHz-4.2 GHz	100 kHz-4.2 GHz: 1.20 ±5%	+25 to +35 dBm	3.5 W avg, 100 W pk 100 W • μs per pulse	N(m)	Net 0.2 kg (0.38 lb) Shipping 0.5 kg (1 lb)
100 mW sensors, 1 mW to 100 mW (-30 to +20 dBm)						
8485A	50 MHz-26.5 GHz	50-100 MHz: 1.15 100 MHz-2 GHz: 1.10 2-12.4 GHz: 1.15 12.4-18 GHz: 1.20 18-26.5 GHz: 1.25	+10 to +20 dBm +2, -4%	300 mW avg, 15 W pk 30 W • μs per pulse	APC-3.5 mm (m)	Net 0.2 kg (0.38 lb) Shipping 0.5 kg (1 lb)
Opt. 033	50 MHz-33 GHz	26.5-33 GHz: 1.40				
8481A	10 MHz-18 GHz	10-30 MHz: 1.40 30-50 MHz: 1.18 50 MHz-2 GHz: 1.10 2-12.4 GHz: 1.18 12.4-18 GHz: 1.28	+10 to +20 dBm +2, -4%	300 mW avg, 15 W pk 30 W • μs per pulse	N(m)	
8482A	100 kHz-4.2 GHz	100-300 kHz: 1.6 00.3-1 MHz: 1.20 1 MHz-2 GHz: 1.10 2-4.2 GHz: 1.30	+10 to +20 dBm +2, -4%	300 mW avg, 15 W pk 30 W • μs per pulse	N(m)	Net 0.2 kg (0.38 lb) Shipping 0.5 kg (1 lb)
8483A	100 kHz-2 GHz (75 Ohms)	100-600 kHz: 1.60 600 kHz-2 GHz: 1.18	+10 to +20 dBm +2, -4%	300 mW avg, 10 W pk	N(m)	Net 0.2 kg (0.38 lb) Shipping 0.5 kg (1 lb)
R8486A	26.5-40 GHz	1.4	+10 to +20 dBm +2, -4%	300 mW avg, 15 W pk 30 W • μs per pulse	Waveguide Flange UG-599/U	Net 0.26 kg (0.53 lb) Shipping 0.66 kg (1.3 lb)
Q8486A	33-50 GHz	1.5	10 to +20 dBm +2, -4%	300 mW avg, 15 W pk 30 W • μs per pulse	Waveguide Flange UG-383/U	Net 0.26 kg (0.53 lb) Shipping 0.66 kg (1.3 lb)
8487A	50 MHz-50 GHz	50-100 MHz: 1.15 100 MHz-2 GHz: 1.10 2-12.4 GHz: 1.15 12.4-18 GHz: 1.20 18-26.5 GHz: 1.25 26.5-40 GHz: 1.30 40-50 GHz: 1.50	+10 to +20 dBm +2, -4%	300 mW avg, 15 W pk 30 W • μs per pulse	2.4 mm (m)	Net 0.14 kg (0.28 lb) Shipping 0.5 kg (1 lb)
High sensitivity sensors, 100 pW to 10 mW (-70 to -20 dBm)						
8481D^{3,4}	10 MHz-18 GHz	10-30 MHz: 1.40 30 MHz-4 GHz: 1.15 4-10 GHz: 1.20 10-15 GHz: 1.30 15-18 GHz: 1.35	-30 to -20 dBm ±1%	100 mW avg 100 mW pk	N(m)	Net 0.18 kg (0.41 lb) Shipping 0.9 kg (2 lb)
8485D³	50 MHz-26.5 GHz	0.05-0.1 GHz: 1.19 0.1-4 GHz: 1.15 4-12 GHz: 1.19 12-18 GHz: 1.25 18-26.5 GHz: 1.29	-30 to -20 dBm ±2%	100 mW avg 100 mW pk	APC-3.5mm (m)	Net 0.2 kg (0.38 lb) Shipping 0.5 kg (1 lb)
Opt. 033	50 MHz-33 GHz	26.5-33 GHz: 1.35				
8487D³	50 MHz-50 GHz	0.05-0.1 GHz: 1.19 0.1-2 GHz: 1.15 2-12.4 GHz: 1.20 12.4-18 GHz: 1.29 18-34 GHz: 1.37 34-40 GHz: 1.61 40-50 GHz: 1.86	-30 to -20 dBm ±2%	100 mW avg 100 mW pk	2.4 mm (m)	Net 0.2 kg (0.38 lb) Shipping 0.5 kg (1 lb)
R8486D³	26.5-40 GHz	1.4	-30 dB to -25 dBm ±3%	100 mW avg or pk 40 Vdc max	Waveguide UG-599/U	Net 0.26 kg (0.53 lb) Shipping 0.66 kg (1.3 lb)
Q8486D³	33-50 GHz	1.4	-25 dB to -20 dBm ±5%		Waveguide UG-383/U	

¹ Negligible deviation except for those power ranges noted.

² For pulses greater than 30W the maximum average power (P_{avg}) is limited by the energy per pulse (E) in W μs according to $P_{avg} = 30 \cdot 0.02E$.

³ Includes HP 11708A 30 dBm atten for calibrating against a 0 dBm, 50 MHz power ref. HP 11708A is factory set to 30 dB +0.05 dB at 50 MHz, traceable to NIST. SWR <1.05 at 50 MHz.

⁴ This sensor directly replaces the popular HP 8484A Power Sensor.

Signal Analyzers

Digital Multimeter

HP 70110A

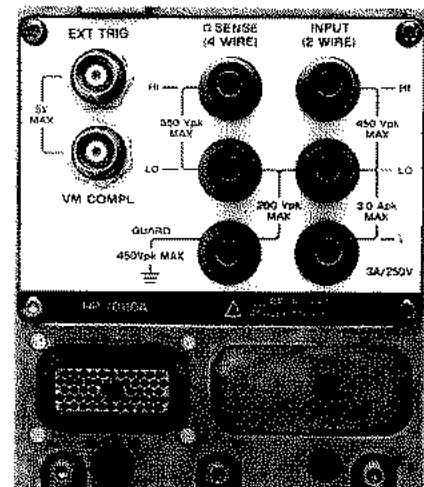
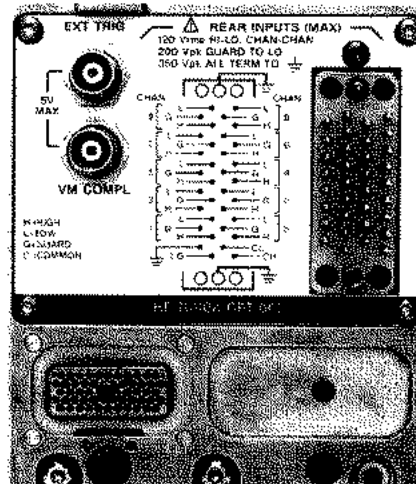
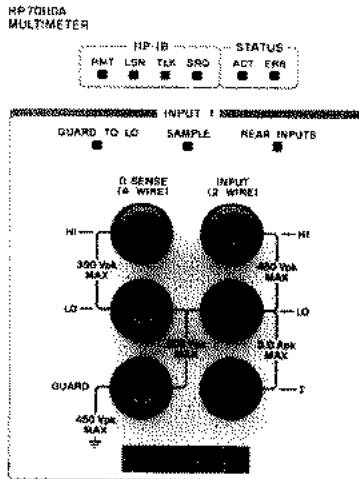

The HP 70110A digital multimeter (DMM) is designed specifically for ATE environments. It collects data rapidly at 1450 readings per second. A complete set of math functions allows you to manipulate data using the DDM instead of your controller. All functions, including switching the guard to low and switching between front and rear inputs, are accessible using SCPI-compatible remote commands.

Specialized signals (voltmeter complete and external trigger) used in ATE systems to synchronize fast measurements with external multiplexers are available on the rear panel.

The DMM requires two slots in the MMS mainframe, and it provides 3 1/2 to 6 1/2 digits of resolution. The basic dc accuracy is 5 ppm, and common mode rejection is greater than 90 dB (up to 180 dB guarded and 166 dB guard-to-low).

Functions include dc volts, ac volts (true RMS), 2-wire Ω , 4-wire Ω , dc current, ac current (true RMS), frequency, and period.

Memory

The HP 70110A multimeter includes 128K of RAM to store 16,384 readings (all aperture times). Memory also provides storage for 10 states.

Electronic calibration

Once the instrument leaves the factory, it will typically never again require manual adjustment. An electronic Auto Cal, taking less than 30 seconds without an external source, is used to meet 24 hour specifications.

When calibration to external standards is required, a security code allows you to enable the calibration routines. This electronic key, plus a system which tracks the number of calibrations performed, protects against calibration tampering.

Diagnostic self test

An extensive self test is built in to verify more than 90% of the measurement-instrument circuitry. If a failure does occur, this remotely activated operation will help isolate the problem.

Rugged and reliable

As part of the MMS family, the multimeter has no problem meeting the rugged requirements for fielded test systems. It meets the following:

- MIL-T-28800, Type III, Class 3, vibration and shock
- Operation at 40° C and 95% relative humidity
- MIL-STD 461, RE 02, Part 5

Signal Analyzers

Digital Multimeter

HP 70110A

Inputs and outputs

The standard instrument comes with banana jacks on both the front and rear panels. All standard measurements can be made to the same specifications with either set of inputs.

Two optional configurations replace the rear panel inputs with multiplexed inputs. These options allow for scanning multiple inputs or ATE system functions independent of DMM measurements. The multiplexers used for scanning are a calibrated part of the DMM.

The Option 001 armature relay multiplexer provides eight 2-wire or four 4-wire armature relay channels with guard and with two current/actuator channels, also with guard. This option allows 250 V maximum high to low, and switches at 33 channels per second.

The Option 002 reed relay multiplexer provides ten 2-wire or five 4-wire reed relay channels with guard. It accepts 120 Vrms maximum terminal to terminal, and switches at 300 channels per second.

Specifications

Electrical measurement performance closely parallels that of the HP 3457A multimeter. Selected specifications are listed below. (For complete specifications, contact your HP sales representative.)

DCV accuracy	300 mV range: 5 ppm 3 V range: 3.5 ppm
DC resistance	Accuracy: 52 ppm Resolution: 10 $\mu\Omega$
DC current	Accuracy: 300 mA, 2 A: 0.03% Accuracy other ranges: 20 ppm
Resolution	DCV: 10 nV ACV: 10 nV
Maximum input range	HI to LO: 450 Vdc, 450 Vac peak I.O to guard: 200 Vdc, 200 Vac

Ordering Information

HP 70110A digital multimeter

- Option 001 armature relay multiplexer
- Option 002 reed relay multiplexer
- Option 910 extra user manual
- Option 915 service material
- Option W30 two additional years of return-to-HP warranty (3 years total)

Signal Analyzers

Universal Counter

HP 70120A

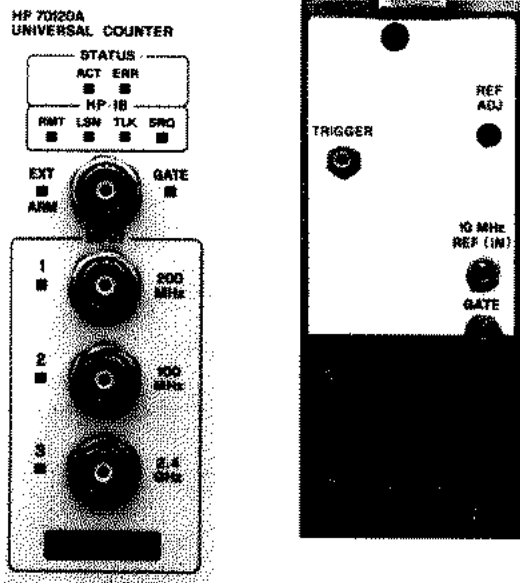

The HP 70120A universal counter was designed with ATE environments in mind. It offers the high speed setup and measurements (60 measurements per second) required in today's manufacturing and test environment. High production throughput is crucial in keeping you ahead of the competition. High throughput, system reference monitoring, and all the features you expect from a universal counter are available with SCPI-compatible remote commands.

The single-slot HP 70120A provides three channels: 100 MHz (± 2), and 2.4 GHz (± 64). The 100 MHz and 200 MHz inputs may be switched between 1 M Ω or 50 Ω , and have a sensitivity of 35 mV rms (100 mV pk-pk). The 2.4 GHz input is 50 Ω (ac coupled), with a sensitivity of -30 dBm at 100 MHz and -10 dBm at 2.4 GHz. The 100 MHz and 200 MHz inputs have an internal x10 attenuator available, allowing inputs up to ± 100 V peak. The maximum level for the 2.4 GHz input is 5 Vrms (± 30 V dc).

Built-in functions include frequency, period, time interval, rise and fall times, ratios, totalize, pulse width,

and voltage minimum and maximum for ac or dc.

Built-in TCXO

Standard on the HP 70120A, this 10 MHz reference gives you the option of locking to a house standard or remotely switching in the internal TCXO. The internal TCXO can be ported externally for use as a system reference. A monitoring scheme continuously samples the reference in use, internal or external, even when the HP 70120A is inactive.

If a problem occurs, this monitoring scheme can immediately provide an interrupt.

Inputs and outputs

In addition to the three main inputs, an external-arm input is provided. Rear inputs include trigger in, 10 MHz reference in or out, and a gate input.

Ordering Information

HP 70120A universal counter

Option 910 extra user manual

Option 915 service material

Option W30 two additional years of return-to-HP warranty (3 years total)

2.4 GHz

Error message for failed external reference

MIL-rugged

Specifications

Frequency	
Range	0.001 Hz to 2.4 GHz
Resolution	9 digits in 1 s
Period	
Range	5 ns to 15,000 s
Resolution	9 digits in 1 s
Time interval	
Range	1 ns to 15,000 s
Resolution	100 ps (averaging) 2 ns (single shot)
Rise/fall time	
Range	15 ns to 15,000 s
Resolution	100 ps (averaging) 2 ns (single shot)
Ratio (channel 1/channel 2)	
Range	0.001 Hz to 100 MHz
Totalize	
Range	0 to $10^{12}-1$ events
Pulse width	
Range	5 ns to 1 ms
Resolution	100 ps (averaging) 2 ns (single shot)

Signal Analyzers

Digitizer

HP 70700A

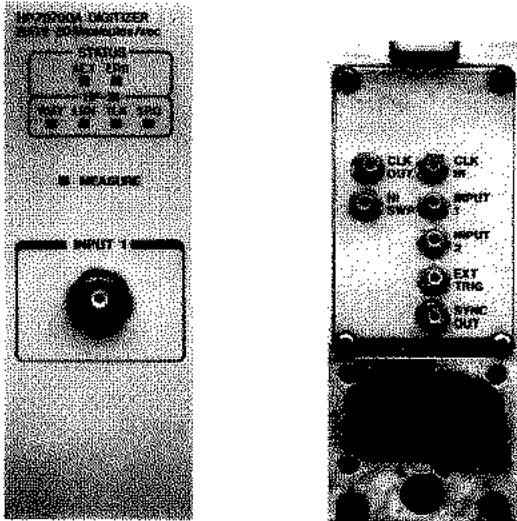

20 M samples/s, 10 bits

256K memory

Waveform recorder and oscilloscope features

Up to eight channels

Faster spectrum analyzer sweeps

The HP 70700A digitizer adds precision digitizing capability to the modular measurement system. This one-slot module has all the features you expect to find in a 20-Msample/s, 10-bit programmable waveform recorder and more, including a full set of oscilloscope features, powerful analysis functions, and memory size of 256K samples. Integrated into an HP 70000 modular spectrum

analyzer, the digitizer module improves the system's ability to analyze signals in the time domain. The high sampling rate allows recovery of fast pulses—limited only by the bandwidth of the spectrum analyzer's signal path.

The digitizer module also functions as a self-contained instrument with comprehensive data-acquisition and

waveform analysis capabilities. This flexible module can be used as a precision digitizing oscilloscope, a transient analyzer, or a programmable waveform recorder. In multi-channel applications, up to eight HP 70700A modules can be operated synchronously without loss in performance.

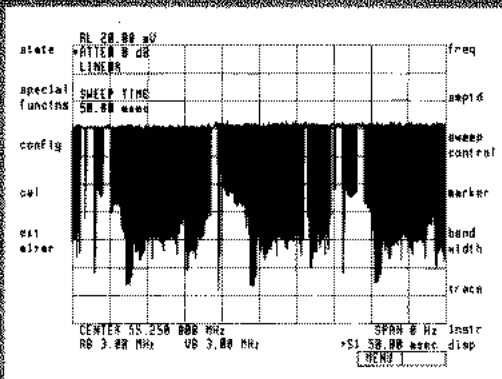

(A) Spectrum analyzer performance in zero span without the digitizer.

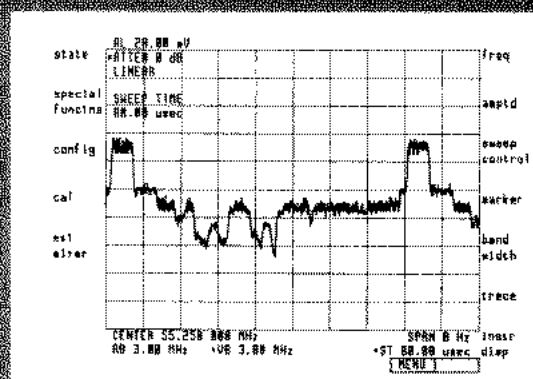

(B) Adding the digitizer improves the spectrum analyzer's ability to recover modulation.

Signal Analyzers

Digitizer

HP 70700A

Capture transient events

The HP 70700A provides a powerful transient analysis feature called Random Event Capture. With this feature, randomly occurring events are stored sequentially in segmented memory as they happen, complete with pre-trigger data and timing information (see the diagram on the right). Random Event Capture makes efficient use of memory by eliminating dead time from the stored trace. This allows analysis of infrequent transient waveforms. Random Event Capture requires no re-arm time, so multiple transients are always captured with no loss of data.

Built-in oscilloscope features include

- Menu-driven user interface
- Auto-scale
- Pre-trigger data
- FFT
- Time and voltage markers
- Split timebase mode
- 256K sample memory
- Trace averaging
- Automatic pulse parameter measurements
- Waveform math functions (add, subtract, and multiply waveforms)
- Multi-channel capability (control up to four channels/modules from the menu)
- Equivalent time sampling (measure rise times as short as 10 nanoseconds of a restricted class of waveforms: the waveforms must be strictly periodic with a fundamental frequency that is both less than 10 MHz and not an integer sub-multiple of the 20 MHz clock frequency)
- Detection sampling modes (obtain a sub-sampled waveform by dividing the time axis into uniform intervals and retaining from each the maximum or minimum value of the original sampled waveform)

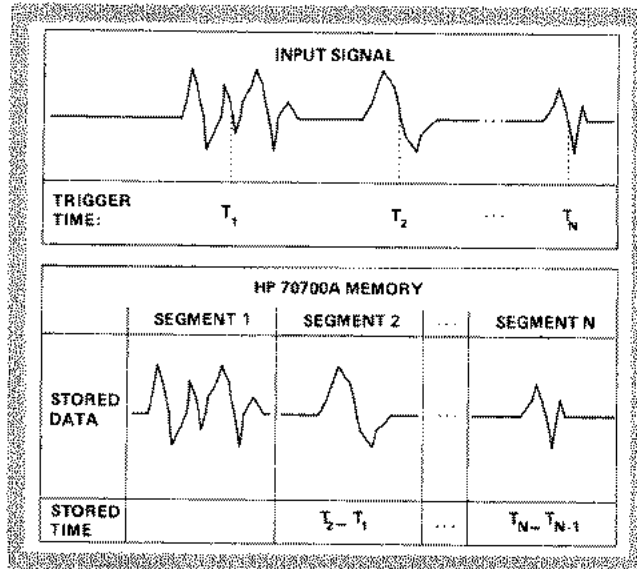

Random Event Capture efficiently uses the internal memory to store transient events.

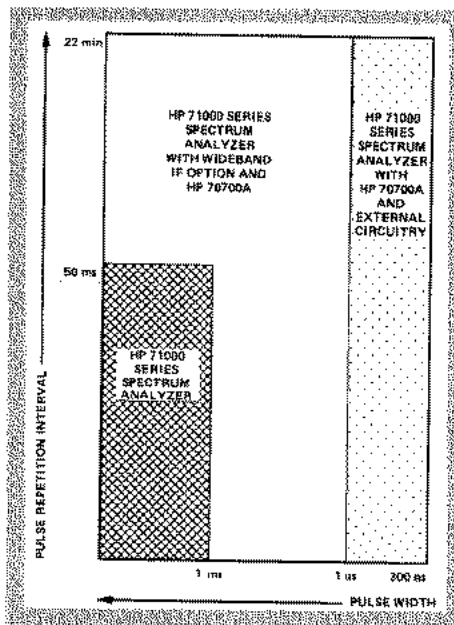

Pulse performance with an HP 70000 spectrum analyzer

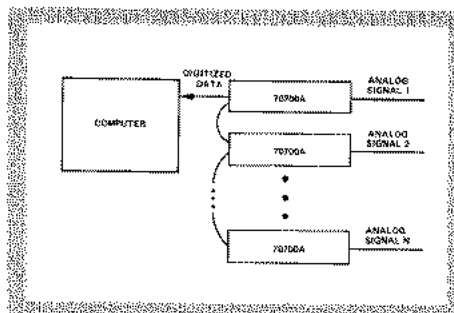

Multi-channel digitizers used for parallel, synchronous data acquisition

Signal Analyzers

Digitizer

HP 70700A

Specifications

Digitizing performance

Maximum sampling rate	20 M Sa/s
Available sampling rates using internal clock	$(2.0 \times 10^7)/n$ Sa/s where $n = 1, 2, 3, \dots, 2^{23}, \pm 1\%$
Amplitude resolution	10 bits
Effective number of bits ¹	7.5 @ 1 MHz; 7.0 @ 10 MHz
Harmonic and spurious distortion	50 dBc at 1 MHz; 45 dBc at 10 MHz
Gain accuracy	$\pm 1\%$
Offset accuracy	$\pm 1\%$

Bandwidth

Single-shot bandwidth	10 MHz
Analog (3 dB) bandwidth	> 35 MHz

Analog input

Input coupling	Switchable, ac 1 M- Ω , dc 1 M- Ω , DC 50- Ω (nominal); all with 60 pF capacitance (nominal)
Input voltage ranges (full scale)	± 0.3 V, ± 1 V, ± 3 V, ± 10 V (nominal)

Data Acquisition

Waveform memory	262,144 (256K) 10-bit words
Data transfer rate	60 KB/s (nominal; depends on speed of receiving instrument)
Special features	<input type="checkbox"/> Random Event Capture <input type="checkbox"/> Built-in oscilloscope functions <input type="checkbox"/> Built-in analysis functions <input type="checkbox"/> Interpolation of sparsely sampled waveforms <input type="checkbox"/> Variable pre- and post-trigger data <input type="checkbox"/> Adjustable fast Fourier transform (FFT)
Programmability:	Fully programmable via HP-IB interface

Specification Changes to the HP 70000 Spectrum Analyzer Systems with the HP 70700A Module

Sweep time

Swept frequency span ²	15 ms to 335 s with trace lengths of 800 pts ²
Fixed frequency (zero span)	80 ms to 335 s with trace lengths of 800 pts
A sweep time accuracy of 2% is ensured if either of the following conditions is met	<input type="checkbox"/> Sweep time = (trace length x 5.0 ms) <input type="checkbox"/> Sweep time = (n x trace length x 100 ns), where n is an integer

Frequency

Frequency span accuracy

<input type="checkbox"/> span ≤ 10 MHz x N	$\pm [1\% \text{ of span} + (\text{span} \times \text{freq ref acc})]$
<input type="checkbox"/> span > 10 MHz x N	$\pm 5\% \text{ of span}$

Frequency readout accuracy

<input type="checkbox"/> span ≤ 10 MHz x N	$\pm [(\text{freq readout} \times \text{freq ref acc}) + 1\% \text{ of span} + K]$
<input type="checkbox"/> span > 10 MHz x N	$\pm [(\text{freq readout} \times \text{freq ref acc}) + 2\% \text{ of span} + K]$
<input type="checkbox"/> span > 200 MHz x N	$\pm [(\text{freq readout} \times \text{freq ref acc}) + 5\% \text{ of span} + K]$

[K = 10 Hz with spectrum analyzers without HP 70907A/B. When used with the HP 70907A/B, K = 300 Hz or 35% of Res BW (whichever is greater). N is the harmonic mixing band number or the harmonic multiplier, and is unity for the HP 71100C/P.]

Amplitude accuracy

Displayed digitizing resolution:	0.12 dB
General dimensions:	1 slot
Weight:	2.2 kg (4.9 lb)

¹ A measure of dynamic performance. Consult HP Product Note 5180A-2, "Dynamic Performance Testing of A to D Converters."

² Faster sweeps are possible with shorter traces.

Ordering Information

HP 70700A digitizer module

Option 098 controller board upgrade kit (required only if digitizer is being added to an existing system with HP 70900A/B local oscillator module firmware version 860203 or earlier)

Option 099 firmware upgrade kit (not required if ordering Option 098; required only if digitizer is being added to an existing system with HP 70900A local oscillator)

Option 910 extra user manuals

Option 915 extra technical reference manual

Option 1BN certificate of calibration

Option 1BP certificate of calibration and data

Accessory probes

HP 10001A 10:1 (10 M)

HP 10002A 50:1 (9 M)

HP 10007B 1:1 (1 M)

HP 10026A 1:1 (50)

Signal Analyzers

Digitizing Oscilloscope

HP 70703A

500 MHz repetitive bandwidth

Four-input, two-channel operation

20 M Sa/s sampling rate

The four-channel HP 70703A oscilloscope was designed for use in ATE systems. In repetitive measurements, it provides 500 MHz of bandwidth. A 20 mega-sample-per-second sampling rate allows single-shot measurements to 2 MHz.

Dual-time-base windowing allows for closer inspection of pulse edges. Automatic measurements, autoscale, and waveform math make for very fast test development and execution.

A wide range of vertical sensitivity (1 mV/div to 5 V/div), a full function attenuator, and 8-bit vertical resolution provide ample amplitude freedom. All inputs can be switched between 1 M Ω and 50 Ω , and ac or dc coupling. Any two channels can sample simultaneously.

The HP 70703A requires two slots in the MMS mainframe.

HP 70703A DIGITIZING OSCILLOSCOPE
RANGE DC-500MHz

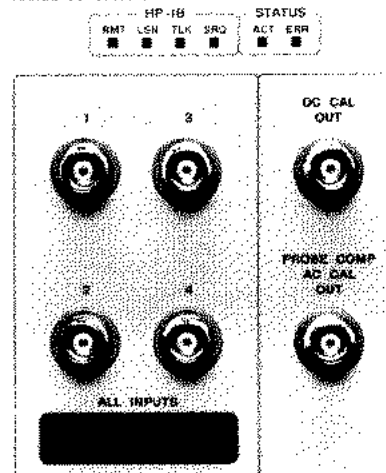

Waveform manipulation

Four non-volatile waveform memories can store digitized channel data or data downloaded from a controller. Two independent functions can operate on digitized channels or stored waveforms. The operators available for these functions are *plus*, *minus*, *times*, *versus*, *invert*, and *only*.

Electronic calibration

The HP 70703A was designed to never again require manual adjustment after it leaves the factory. Routine calibration is performed electronically and only requires connecting the calibration signal provided on the front panel to each input in turn. No external test equipment is required. Calibration data is stored in non-volatile memory.

Self test diagnostic

An extensive diagnostic self test is built into the HP 70703A. This self test can be initiated, and the test results queried, remotely. Error reporting occurs for both the functional block level and the assembly level to expedite repair, if necessary.

Signal Analyzers

Digitizing Oscilloscope

HP 70703A

Specifications

Vertical specifications

Calculated rise time	700 ps
DC gain accuracy	$\pm 1.25\%$
Resolution	$\pm 0.4\%$ (8-bit ADC) $\pm 0.1\%$ (averaging)
Voltage measurement accuracy	<input type="checkbox"/> Dual cursor: $\pm(1.25\%$ full scale + 0.032 divisions) <input type="checkbox"/> Single cursor: $\pm(1.25\%$ full scale + offset accuracy + 0.016 division)
Input capacitance	7 pF
Maximum input voltage	1 M Ω ± 250 V (dc + peak ac < 10 kHz) 50 Ω 5 Vrms
Dynamic range (dc + peak ac)	± 1.5 x full scale from center of screen
Channel isolation (channels at equal sensitivity)	<input type="checkbox"/> DC to 100 MHz: 40 dB <input type="checkbox"/> 100 to 500 MHz: 30 dB

Horizontal specifications

Time base range	200 ps/div to 5 s/div
Time base reference accuracy	0.005%
Time base resolution	20 ps
Delta time accuracy	$\pm 2\%$ of s/div $\pm 0.005\%$ of $\Delta t \pm 100$ p
Trigger level range	± 1.5 x full scale from center of screen
Minimum trigger pulse width	1.5 ns
Waveform record length	Display 501 points Remote (HP-IB) 1024 points

Ordering Information

HP 70703A digitizing oscilloscope

Option 910 extra user manual

Option 915 service material

Option W30 3 year customer return repair

Signal Analyzers

Microwave Transition Analyzer

HP 71500A

DC-40 GHz with two channels

Time domain measurements with FFTs

Up to 1 ps delta time accuracy

Magnitude and phase measurements on pulsed-RF signals to 100 ps pulse widths and 25 ps edges

Analysis of AM, FM, and PM on RF carriers

Stepped frequency and power sweeps, magnitude, and phase

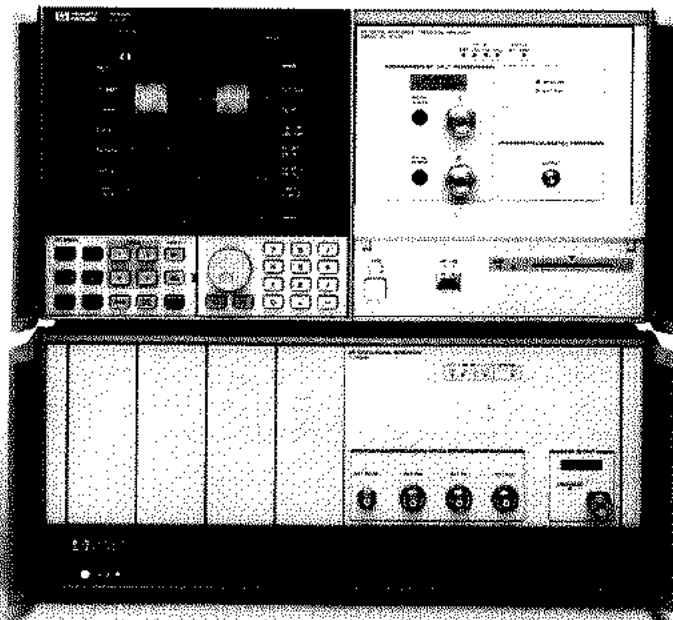

The HP 71500A microwave transition analyzer is a two-channel, sampler-based time-domain instrument for measurements from dc to 40 GHz. It consists of the HP 70820A microwave transition analyzer module and an HP 70004A color display/mainframe.

The instrument makes continuous-wave and pulsed RF measurements, specializing in measuring fast magnitude and phase transitions. Performance specifications include 1 ps delta time accuracy, 10 ps rise and fall time (25 ps for pulsed RF), and internal triggering to 40 GHz. You can measure magnitude and phase settling times, rise and fall times, time delay, peak and average power, group delay, AM to PM conversion, and more.

The HP 71500A incorporates measurement functions from many instruments: oscilloscope, vector network analyzer, vector voltmeter, spectrum analyzer, modulation domain analyzer, frequency counter, and peak power meter. Compact MMS format makes the HP 71500A ideal for use in ATE systems or anywhere that

downsizing and measurement versatility are required. Optimal performance requires use of a synthesized source, which you order separately.

Generate custom solutions with IBASIC

The HP 71500A allows you to generate custom, application-specific interfaces through the internal execution of HP Instrument BASIC programs. IBASIC eliminates the need for an external controller by bringing the computer inside the analyzer. Programs can be generated and edited by attaching a standard HP-HIL keyboard to the front of the mainframe. Key logging provides a quick and easy way to generate remote command equivalents of front panel key presses. Also incorporated into the HP 70004A mainframe is a memory card interface that can be used as a disk drive for the system. External disk drives are also supported over the HP-IB interface.

The HP 71500A provides extensive trace processing, including arithmetic and calculus math operations, complex formats, digital demodulation, FFTs, and more. This capability, combined with IBASIC's ability to generate custom user interfaces, multi-step procedures, and programmable control of other instruments, allows for completely customized measurements.

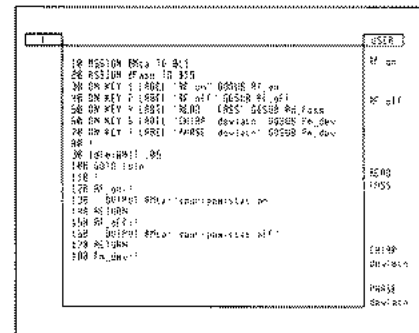

IBASIC programs allow generation of custom user interfaces.

Signal Analyzers

Microwave Transition Analyzer

HP 71500A

Pulsed-RF component test

For time domain measurements on components such as high power solid-state and traveling wave tube amplifiers and active RF switches, the microwave transition analyzer offers four ways of viewing pulsed-RF signals:

- Real format, an RF waveform display similar to that of an oscilloscope
- Magnitude format, an RF envelope display with linear scaling
- Log magnitude format, an RF envelope display with log scaling
- Phase format, a display of RF phase versus time within the pulse

The analyzer measures signals with pulse widths to 100 ps. Triggering on the pulse envelope stabilizes waveforms for making rise and fall time measurements. You can directly measure video feedthrough or the RF carrier, because the microwave transition analyzer can separate and remove the video feedthrough without external filters.

The HP 71500A's ability to control a synthesizer allows for stepped frequency and power sweeps. This allows measurements of gain, phase, group delay, and AM to PM conversion.

The HP 71500A also has the ability to tune to a frequency that is offset from or is a harmonic of the input frequency. This allows for measurement using frequency-translating devices, and for harmonic power sweeps.

Radar test

You can test synthesized radar systems with measurements such as deviation from linear chirp and Barker code timing. The HP 71500A displays amplitude, phase, and frequency-versus-time for modulation rates to greater than 1 GHz. Maximum frequency deviation is equal to 500 divided by the time span in seconds.

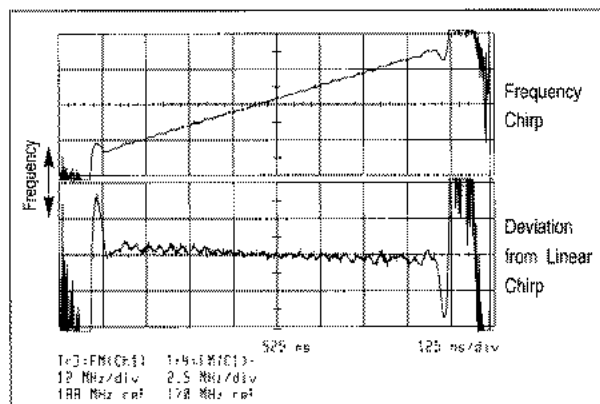

Verify system chirp performance: The lower trace uses math functions to show deviation from linear chirp. Deviation from parabolic chirp could also be defined and displayed.

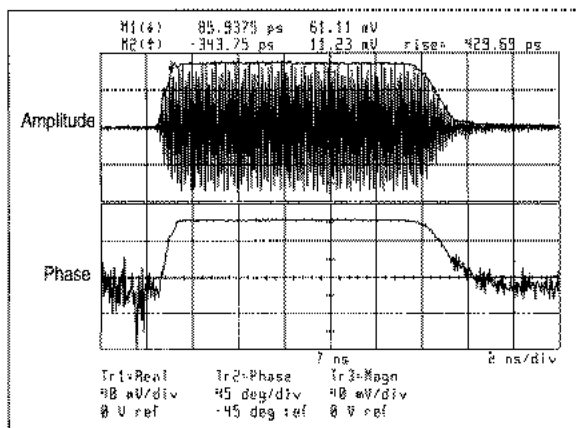

Measure fast pulses: Magnitude and phase versus time of a 12 ns wide pulse of RF. A log magnitude display is also possible.

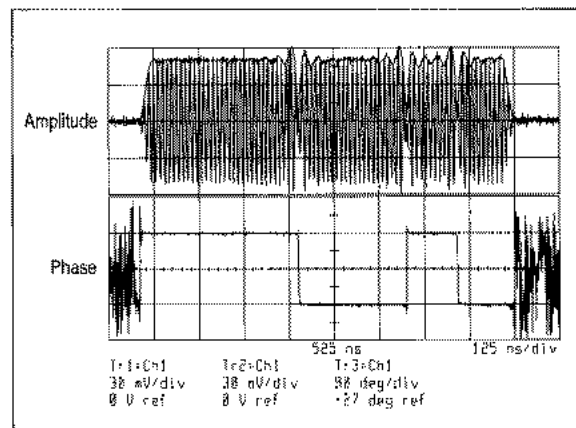

Check Barker code response: Phase demodulation allows measurement of phase encoding within a pulse of RF. A Barker code is shown here.

Signal Analyzers

Microwave Transition Analyzer

HP 71500A

Satellite test

On frequency-translating devices such as satellite transponders, the HP 71500A can make several measurements, including group delay, AM to PM conversion, and gain/phase linearity versus drive level. No external mixers are needed, as would be required with a network analyzer.

Non-linear microwave analysis

Characterizing the non-linear behavior of high power devices and amplifiers is easy with the HP 71500A. With 40 GHz internal triggering, you can directly view non-linear effects in the time domain. A fast Fourier transform (FFT) display can simultaneously show the signal and its harmonics in the frequency domain. To aid in the development and verification of models for high power devices, the

instrument can display results in tabular (numerical) format with both magnitude and phase of the harmonics. These results can then be used for or compared with CAE simulations.

The HP 71500A also allows the user to enter corrections in the form of magnitude and phase versus frequency. This information can then be applied in the time domain, to correct for cable or fixture losses, for example.

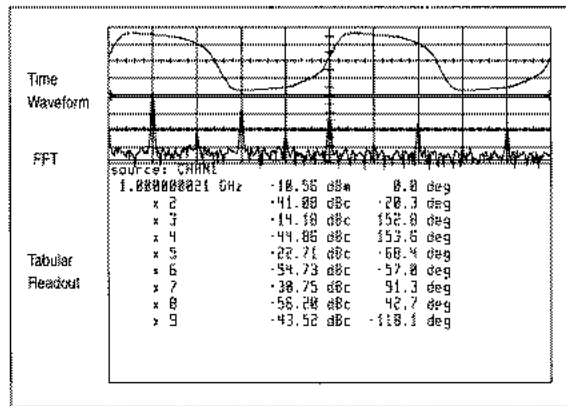

Simultaneously display time and FFT: Time and frequency domains fully characterize RF and microwave signal distortion. Tabular format allows easy comparison of results to CAE simulations.

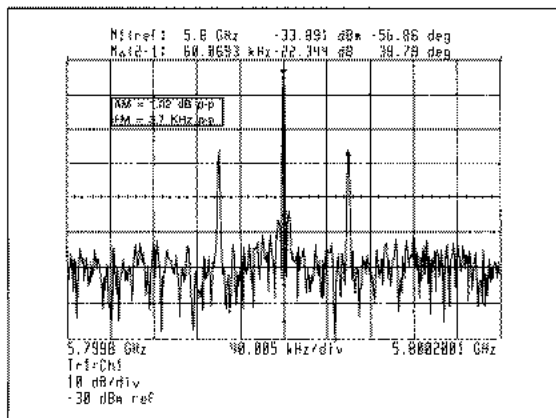

Measure AM, FM and PM: Markers read amplitude and phase of modulation sidebands, allowing for computation of AM, FM, and PM components.

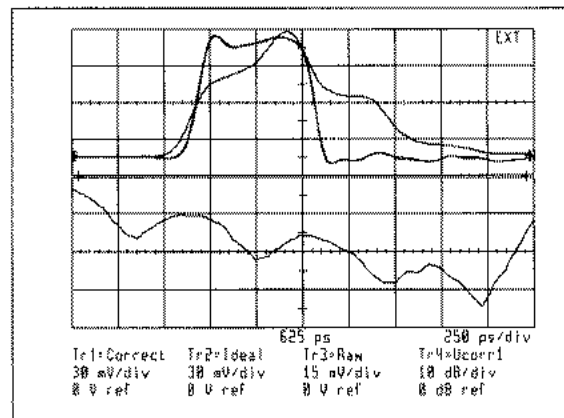

Correct for cable losses: Top half shows reference and corrected traces, which are virtually indistinguishable, as well as the wider, uncorrected pulse. Bottom trace shows the user corrections in the frequency domain.

Signal Analyzers

Microwave Transition Analyzer

HP 71500A

Ordering Information

HP 71500A microwave transition analyzer system

Includes

- HP 70004A color display and mainframe
- HP 70820A microwave transition analyzer module, dc-40 GHz
- Adapter and cable accessories
- External power pack
- 1 meter HP-IB cable accessories (HP P/N 8120-3445)
- User manual sets for the HP 70004A and the HP 70820A

Synthesized source must be ordered separately.

Options available for the HP 71500A

- 001 delete adapter and cable accessories
 - 002 delete external power pack (HP P/N 70310-60016)
External power pack supplies power to the HP 70820A's frequency reference oven when MMS mainframe power is turned off
 - 003 add tutorial kit
Includes tutorial and demonstration parts for a self-paced class on the operation and capabilities of the HP 71500A/HP 70820A
 - 810 add rackmount slide kit (HP P/N 5062-7086)
 - 908 add rack flange kit
For mounting mainframes without handles (HP P/N 5062-3979)
 - 910 add extra set of user manuals
 - 913 add rack flange kit
For mounting mainframes with handles attached (HP P/N 5062-4073)
 - 915 add service manuals
Includes assembly level service manual and component level information for the HP 70820A and HP 70004A
-

HP 70820A microwave transition analyzer module

Includes

- HP 70820A module
- Adapter and cable accessories
- HP 70820A user manual set
- Option W30 two additional years of return-to-HP warranty (3 years total)
- Option W50 Five year customer return repair coverage

Additional information

Color brochure, part number 5091-0791E

Product notes

A Versatile Measurement Set for Bench and Test (70820-1), product number 5952-2543E

Measure 25 ps Transitions in Switched and Pulsed Microwave Component Testing (70820-2), part number 5952-2546E

Picosecond Delta Time Accuracy (70820-3), part number 5952-2545E

Technical data sheet

Specifications and complete ordering information, part number 5091-0792E

Signal Analyzers

Microwave Downconverter

HP 71707A/70427A

Low noise microwave downconverter for phase noise measurements

AM noise detection

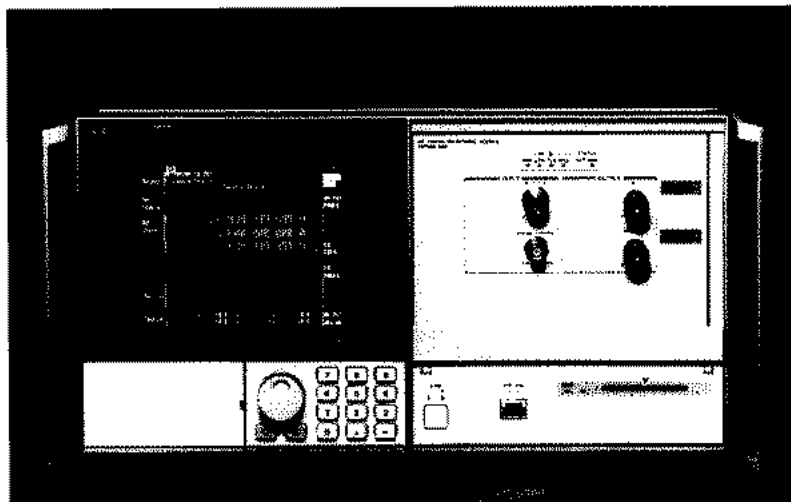

The HP 71707A microwave downconverter translates microwave signals to RF frequencies for use with the HP 3048A and HP E5500 series phase noise measurement systems. The HP 71707A provides state-of-the-art noise floor performance for microwave phase noise measurements. In addition, it provides specified spurious performance and a dc-coupled tuning port with variable sensitivity for phase locking to your microwave source. Components of the HP 71707A include the HP 70427A microwave down-converter module and the HP 70004A color display/mainframe.

Specifications

Frequency range	1.5 GHz to 26.5 GHz
Input power	-40 dBm min, +30 dBm max
IF output frequency range	5 MHz to 1200 MHz
Level	0 to +5 dBm
Local oscillator frequency range	2.4 GHz to 25.8 GHz
Frequency resolution	600 MHz
Spectral purity	Phase noise performance varies with tuning sensitivity. The following table shows the combined phase noise performance of the HP 71707A (set-up with 0.05 ppm tuning sensitivity) using an HP 8662A synthesized signal generator as an RF reference source to the HP 3048A phase noise measurement system. All values are in units of dBc/Hz.

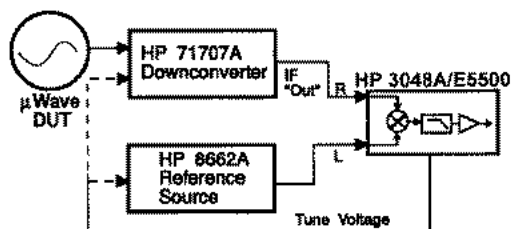

Signal Analyzers

Microwave Downconverter

HP 71707A/70427A

Phase noise performance of the HP 71707A

Input frequency		Offset from carrier (Hz)						
		10	100	1k	10k	100k	1M	10M
1.5 to 3.0 GHz	Typ.	-80	-100	-119	-130	-130	-135	-147
	Spec.	-73	-92	-112	-124	-124	-130	-142
3.0 to 4.2 GHz	Typ.	-77	-97	-122	-133	-136	-141	-149
	Spec.	-72	-92	-115	-128	-131	-136	-144
4.2 to 6.0 GHz	Typ.	-74	-94	-120	-131	-136	-141	-148
	Spec.	-69	-89	-114	-126	-131	-136	-143
6.0 to 7.8 GHz	Typ.	-72	-92	-119	-130	-136	-140	-147
	Spec.	-67	-87	-113	-125	-131	-135	-142
7.8 to 10.2 GHz	Typ.	-70	-90	-118	-129	-135	-139	-145
	Spec.	-65	-85	-112	-124	-130	-134	-140
10.2 to 12.6 GHz	Typ.	-68	-88	-116	-128	-134	-138	-143
	Spec.	-63	-83	-111	-123	-129	-133	-138
12.6 to 18.0 GHz	Typ.	-65	-85	-113	-125	-133	-137	-140
	Spec.	-60	-80	-108	-120	-128	-132	-135
18.0 to 26.5 GHz	Typ.	-62	-82	-110	-122	-128	-133	-136

Supplemental Characteristics

Tuning sensitivity	0.05 ppm/volt, 1 ppm/volt, 20 ppm/volt
Tuning port voltage range	± 5 volts
Tuning port input range	2 k Ω

General Characteristics

Temperature	Operational, 0° to +55° C; storage, -40° to +75° C
Humidity	Operational, 0 to 95% relative humidity at 45° C
Calibration interval	One year recommended
Power	HP 71707A: 260 watts maximum HP 70427A: 50 watts maximum
Weight (nominal)	HP 71707A: 28.75 kg (63.3 lb) HP 70427A: 9.3 kg (20.3 lb)
Size	HP 71707A: 222 mm H x 425.4 mm W x 526 mm D (8.74" x 16.75" x 20.7") HP 70427A: 4-slot width

Ordering Information

HP 71707A microwave downconverter
Includes **HP 70427A** microwave downconverter module
and **HP 70004A** color display/mainframe.
HP 70427A microwave downconverter module

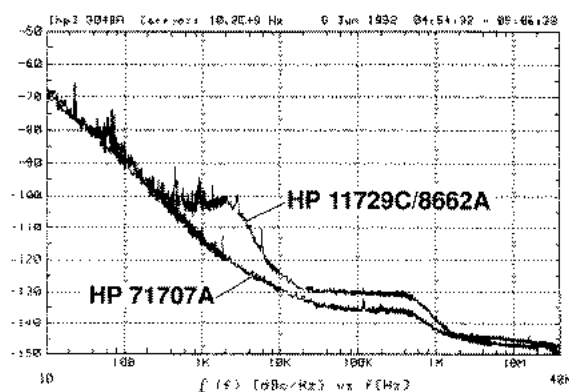

Typical phase noise of HP 71707A and HP 11729C carrier noise test set, using the HP 8662A as a reference

Additional Information

Technical data sheet
HP 71707A/70427A
part no. 5091-4435E

Product Overview

HP E5500 Series Phase Noise Measurement Solutions
part no. 5965-7590E

Signal Analyzers

Wide Bandwidth Receiver

HP 71910A/P

100 Hz to 26.5 GHz operation

*Bandwidths to 36 MHz
with preselection*

*Cost-effective receiver for
surveillance and signal
monitoring applications*

*Flexible downconverter for
stimulus-response measurements*

The HP 71910A/P wide bandwidth receiver monitors signals from 100 Hz to 26.5 GHz. It provides a cost-effective combination of search and wide-bandwidth collection capabilities for the surveillance and signal monitoring of satellite, digital radio, and radar/EW transmissions.

The wide bandwidth receiver consists of the HP 71209A/P Option 001 spectrum analyzer plus the HP 70911A ultra-wide bandwidth IF module. System options include a preamplifier module for enhanced noise figure and a smaller-sized, single mainframe configuration (without the display, narrowband IFs, and precision frequency reference) for remote applications at a lower cost.

The 71910A comes with the HP 70004A display mainframe. The HP 71910P comes with the HP 70207B E05 PC display for MMS.

Search and collection modes of operation

The HP 71910A/P receiver has two modes of operation: search and collection. To search for signals, the receiver relies on fast spectrum analyzer tuning. It sweeps over the spans that you specify, up to 26.5 GHz wide, using bandwidths of up to 3 MHz. Wide dynamic range ensures that signals of various amplitudes are quickly identified.

Once a signal has been located, the receiver is fixed-tuned and the wide IF

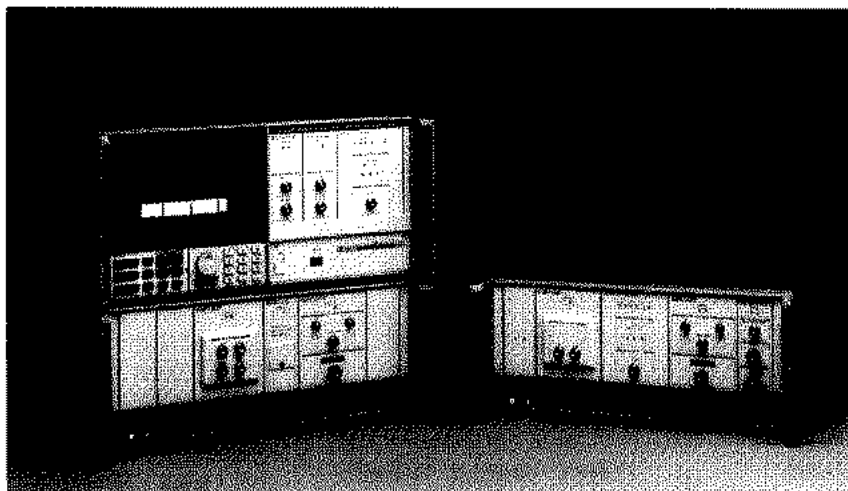

bandwidths in the HP 70911A IF module are used to collect the signal. The HP 70911A provides IF bandwidths up to 100 MHz in 10% increments and up to 70 dB IF step gain. A linear IF signal path provides good signal fidelity with standard outputs of 321.4 MHz IF and linear video. Optional outputs include 70 and 140 MHz IF, analog I/Q, and demodulated FM.

Pulse shape characterization

Traditional shape measurements of pulsed microwave signals using a spectrum analyzer are significantly enhanced by the 100 MHz bandwidth. You can connect an oscilloscope to the video output to easily measure the pulse rise and fall times of microwave signals to 7 ns.

Chirp and frequency hopping

You can make chirp and frequency hopping measurements by connecting the output of the optional FM demodulator to an oscilloscope. Sensitivities of either 10 MHz/V or 40 MHz/V enhance measurement speed and accuracy.

I/Q signal identification

The optional analog I/Q demodulator provides I and Q outputs that will produce a constellation display on an oscilloscope when the HP 71910A/P is tuned to a suitable digitally

modulated signal. Sub-hertz tuning (with a minimum on-screen resolution of 1 Hz) allows ultra-fine adjustments to compensate for phase offsets when it is not possible to phase-lock the receiver to a source, such as in off-the-air monitoring. By stopping the spinning caused by a non-phase-locked system, the system can easily identify modulation formats.

When more thorough analysis is required, the I and Q outputs can be connected to a dual-channel vector signal analyzer (VSA). This configuration can provide full-signal demodulation of microwave signals with double the bandwidth normally provided by the VSA alone.

Channel measurements

To make channel measurements, you can switch optional IF filters into the 70 MHz IF path. This provides an IF output with the bandwidth characteristics of your choice.

Phase measurements in multi-channel systems

HP uses MMS receivers to configure custom multi-channel systems. For example, a system that performs phase measurements can be configured using a modulation domain analyzer connected to the 70 MHz IF outputs in a dual-channel HP 71910A/P system.

Signal Analyzers

Wide Bandwidth Receiver

HP 71910A/P

Specifications

HP 71910A/P collection receiver

Frequency

Frequency range 100 Hz to 26.5 GHz (to 110 GHz with HP 11970 series millimeter mixers or 75 GHz with HP 11974 series preselected millimeter mixers)

Tuning resolution

1 Hz

Frequency reference accuracy

w/HP 70310A w/o HP 70310A
(standard) (Option 110)

Aging

< 1 x 10⁻⁷/year < 3 x 10⁻⁶/year
< 5 x 10⁻¹⁰/day (7 day average)

Temperature drift

< 7 x 10⁻¹⁰ < 1 x 10⁻⁵

IF bandwidth

-3 dB, five pole synchronously tuned

Range

10 MHz to 100 MHz in 10% steps¹

Accuracy

± 15%, 321.4 MHz IF output
± 20% video output

Selectivity (-60 dB/-3dB)

< 12:1, < 8:1 with preselector (characteristic)

Video bandwidth

Range

10 kHz to 30 MHz;
> 100 MHz (1, 3, 10 sequence)

Accuracy (characteristic)

± 30% (10 kHz to 30 MHz)

Gain

RF/IF gain

+5 dB characteristics²

RF attenuation

0 to 65 dB in 5 dB steps

RF preamplifier gain

+28 dB (characteristic), requires Option 016 or 017

IF gain

0 to 70 dB in 1 dB steps

IF step gain accuracy (0 to 55° C)

10, 20, 30, 40 dB ± 0.75 dB
50, 60, 70 dB ± 1.0 dB

IF step gain accuracy (20 to 30° C)

10, 20, 30, 40 dB ± 0.25 dB
50, 60 dB ± 0.3 dB
70 dB ± 0.75 dB

Dynamic range

Third order Intercept

	Standard	Option 016 or 017 ³ (characteristic)	Preamp bypass	Preamp on
20 MHz to 2.9 GHz	9 dBm	11 dBm	-16 dBm	-16 dBm
2.7 to 6.2 GHz	4 dBm	6 dBm	-21 dBm	-21 dBm
6.0 to 26.5 GHz	2 dBm	4 dBm	-23 dBm	-23 dBm

One tone spurious-free dynamic range⁴ (characteristic)

Frequency	Standard	Option 016	Option 017
10 MHz to 12.0 GHz	67 dB	70 dB	56 dB
12.0 to 26.5 GHz	70 dB	70 dB	70 dB

1-dB gain compression (characteristic)

≤ -5 dBm ≤ -5 dBm ≤ -33 dBm

Internally generated spurs⁵

-60 dBm (characteristic) for CF < 2.9 GHz and IF BW > 30 MHz

Linear detector dynamic range⁶

30 dB (characteristic)

Image rejection

for RF input levels < 0 dBm, attenuation > 10 dB

Image frequency	Center frequency	Rejection
642.8 MHz	100 kHz to 2.9 GHz	-85 dBc
	2.7 to 18.0 GHz	-70 dBc
	18.0 to 26.5 GHz	-60 dBc

Noise

Noise figure

Frequency	Standard	Option 016 or 017 ³	
		Preamp bypass	Preamp on
1 MHz to 12.8 GHz	32 dB	33 dB	13 dB
12.6 to 22.0 GHz	39 dB	41 dB	18 dB
22.0 to 26.5 GHz	43 dB	46 dB	21 dB

Phase noise

Noise sidband (dBc/Hz)

Carrier offset⁷

Carrier offset	Standard	Option 016	Option 017
10 kHz	< -108	< -102	< -96

Phase jitter

SSB, 100 Hz to 25 MHz, characteristic

10 MHz to 6.2 GHz

0.2° RMS

6.0 to 12.8 GHz

0.4° RMS

12.6 to 26.5 GHz

0.8° RMS

1 RF/IF bandwidth may be limited by the HP 70910A/P preselector (> 36 MHz) or low-band filter (> 48 MHz).

2 At 321.4 MHz out (assumes 0 dB RF atten and 0 dB IF gain). RF/IF gain is -5 dB at 70 MHz IF output (Option 001); -14 dB at 140 MHz IF output (Option 002), and +5 dB for 70 MHz IF channel filter output (Option 007).

3 Use preamp bypass characteristics below 100 kHz for Option 016 and below 1 GHz for Option 017. Noise figure, TOI, and dynamic range with preamplifier are measured with 5 dB RF attenuation; 1 dB gain compression with preamplifier is measured with 10 dB RF attenuation.

4 Normalized to 1 MHz IF bandwidth. Values given for 0 dB step gain. Varies with step gain.

5 300 MHz residual generated in low band of HP 70910A module. Appears 21.4 MHz away from IF center frequency.

6 Refers to dynamic range at video output of HP 70911A. Assumes IF gain is properly set.

7 N is the harmonic mixing number; N=1 from 100 Hz to 6.2 GHz, N=2 from 6.0 to 12.8 GHz, and N=4+ from 12.6 to 26.5 GHz.

Signal Analyzers

Wide Bandwidth Receiver

HP 71910A/P

Specifications

Inputs and outputs

(Values given are characteristic except as noted. Connectors are on the front panel except as noted.)

HP 70900B LO section

300 MHz calibrator output BNC (f), 50 Ω (nominal)

Output power -10 dBm ± 0.3 dB (specified)

HP 70910A wide bandwidth RF section

RF input APC 3.4, 50 Ω (nominal)

VSWR (> 10 dB attenuation)

□ 0 to 6.2 GHz < 1.4:1

□ 6.0 to 26.5 GHz < 2.0:1

VSWR (< 10 dB attenuation) < 3.0:1

LO emissions (> 10 dB attenuation)	Preselector on	Preselector bypass
0 to 2.9 GHz	< -100 dBm	< -80 dBm
2.7 to 26.5 GHz	< -100 dBm	< -50 dBm

RF bandwidth⁸

0 to 2.9 GHz > 48 MHz

2.7 to 26.5 GHz > 36 MHz

Maximum safe input level (specification)

DC ± 0 V

AC +15 dBm (attenuation = 0)
+30 dBm (attenuation ≥ 10 dB)

Pulse 100 W, 10 μs (attenuation ≥ 50 dB)

321.4 MHz external mixer SMA (f), 50 Ω (nominal)

IF input

Return loss ≥ 14 dB from 271.4 to 371.4 MHz

Maximum safe input level

(specification) AC: 0 dBm; DC: ± 3 V

Noise figure < 7.0 dB

SHI > (+30 conversion loss) dBm

TOI > (+10 conversion loss) dBm

Tune and span output BNC (f), > 10 kΩ load impedance

Voltage range 0 to +13.25 V

Tuning sensitivity RF input chosen, 0.5 V/GHz RF frequency
External mixer, 1.5 V/GHz LO frequency

First LO output SMB (f), 50 Ω, VSWR < 2.1:1

Frequency range 3.0 to 6.6 GHz (spec)

Output power (spec) 25° C ± 5° C 0 to 55° C

□ Minimum 14.5 dBm 14.0 dBm

□ Maximum 17.0 dBm 17.5 dBm

⁸ Measured at RF section 321.4 MHz IF output. For access, user must disconnect from HP 70911A 321.4 MHz IF input.

⁹ IF and demod outputs are inverted for CF < 12.8 GHz due to "minus" harmonic mixing.

¹⁰ Maximum IF BW=100 MHz for 2.6 GHz < CF < 26.5 GHz and preselector bypass. Preselector limits BW to > 36 MHz. For CW < 2.9 GHz, HP 70910A filter limits BW to > 48 MHz. Special option for wider filter available.

¹¹ Maximum peak to peak variation over 80% of the IF output bandwidth.

¹² Symbol error rate measurement with 64-QAM signal at 150 Mb/s with 2 GHz < CF < 12 GHz.

¹³ For 2700-channel loading in a 36-MHz band with 2 GHz < CF < 12 GHz.

HP 70911A ultra-wide bandwidth IF section⁹

Video output BNC (f), 50 Ω (nominal)

Bandwidth (-3 dB) As selected by IF and video BW⁸

Level 0 to 1 V

VSWR < 1.5:1

Rise time < 10 ns

321.4 MHz out Rear panel SMB (m), 50 Ω (nominal)

Bandwidth (-3 dB) IF bandwidth, as selected¹⁰

Group delay variation¹¹ 5 ns (preselector bypassed) 0 to 55° C

VSWR < 2.0:1

321.4 MHz option output Rear panel SMB (m), 50 Ω (nominal)

Bandwidth (-3 dB) IF bandwidth, as selected¹⁰

VSWR < 2.0:1

I and Q video outputs

(Option 004) BNC (f), 50 Ω (nominal)

Level ± 0.5 V

Bandwidth (-3 dB) 50 MHz (each channel)

Quadrature error 6°

I/Q gain imbalance 1.25 dB

Total harmonic distortion < 1% (< -40 dBc)

Spurious emissions -70 dBc (non-harmonic)

Rise time (10 to 90%) 10 ns

Residual DC offset ± 25 mV

VSWR < 1.5:1

FM video output

(Option 005) BNC (f), 50 Ω (nominal)

Level ± 0.5 V

VSWR < 1.5:1

Pk to pk deviation *FM sensitivity Linearity*

□ 10 MHz 0.1 V/MHz ± 0.5%

□ 40 MHz 0.025 V/MHz ± 0.15%

Modulation frequency 12 MHz (max.)

Spurious emissions -35 dBm

70 and 140 MHz IF outputs

(Options 001 and 002) Rear panel SMB (m), 50 Ω (nominal)

VSWR < 1.5:1 (70 MHz); < 2.0:1 (140 MHz)

IF frequency	Preselector	
	70 MHz	140 MHz
Bandwidth (-3 dB)	On 36 MHz	36 MHz
	Bypass 40 MHz	70 MHz
Group delay variation¹¹	On 25 ns	25 ns
	Bypass 25 ns	25 ns

Amplitude variation¹¹ 2.0 dB 4.5 dB

Symbol error rate¹² 1×10⁻⁶ for E_b/N₀ > 25 dB

Noise power ratio¹³ > 40 dB, asymptotic

70 MHz IF channel filters

(Opt. 007, requires Opt. 001) 5 switchable channel filters, 6-pole, 0.1 dB ripple Chebyshev -3 dB

IF bandwidths are 1.25, 5, 10, 20, 36 MHz

Signal Analyzers

Wide Bandwidth Receiver

HP 71910A/P

HP 71910A/P search receiver specifications

Frequency			
Frequency range	See specifications for collection receiver		
Frequency readout accuracy			
Span ≤ 10 MHz x N^{14}	\pm [(freq readout x freq ref acc) + 1.0% of span + 10 Hz]		
Span > 10 MHz x N^{14}	\pm [(freq readout x freq ref acc) + 1.5% of span + 10 Hz]		
Sweep ≥ 20 ms	\pm [(freq readout x freq ref acc) + 1.5% of span + 10 Hz]		
10 ms \leq sweep < 20 ms	\pm [(freq readout x freq ref acc) + 2.5% of span + 10 Hz]		
Frequency span accuracy			
Span < 10 MHz x N^{14}	\pm [1% of span + (span x freq ref acc)]		
Span > 10 MHz x N^{14}	\pm [1.5% of span + (span x freq ref acc)]		
Sweep ≥ 50 ms	\pm [1.5% of span + (span x freq ref acc)]		
50 ms $>$ sweep > 20 ms	\pm [2.5% of span + (span x freq ref acc)]		
20 ms $>$ sweep > 10 ms	\pm [4.0% of span + (span x freq ref acc)]		
Tuning resolution See specifications for collection receiver			
Frequency reference accuracy See specifications for collection receiver			
Phase noise Noise sideband (dBc/Hz), characteristic			
<i>Carrier offset¹⁴</i>	<i>N=1</i>	<i>N=2</i>	<i>N=4</i>
<input type="checkbox"/> 100 Hz	-85	-79	-73
<input type="checkbox"/> 300 Hz	-88	-82	-76
<input type="checkbox"/> 1 kHz	-94	-88	-82
<input type="checkbox"/> 3 kHz	-104	-98	-92
<input type="checkbox"/> 10 kHz	<-108	<-102	<-96
<input type="checkbox"/> 30 kHz	-111	-105	-99
<input type="checkbox"/> 100 kHz	-115	-109	-103
<input type="checkbox"/> 300 kHz	-123	-117	-111
<input type="checkbox"/> 1 MHz	-135	-129	-123
<input type="checkbox"/> 3 MHz	-145	-139	-133
<input type="checkbox"/> 10 MHz	-153	-147	-141
Line and system related sidebands	< 65 dBc + 20 log N^1		

Residual FM	
Span > 10 MHz x N^{14}	< N^{14} x 25 kHz p-p in 0.1 s (measurement bandwidth = 100 kHz)
Span < 10 MHz x N^{14}	Determined by phase noise see phase noise section of specifications for collection receiver
Frequency drift ± 1 kHz/s during sweep	
(span > 10 MHz x N^{14})	Not cumulative from sweep to sweep ± 150 kHz/ $^{\circ}$ C
Sweep time	
Range	10 ms to 1000 s (continuous)
Accuracy	$\pm 2\%$
with HP 70700A	Swept freq. spans: 15 ms to 355 s Fixed freq. (0 span): 80 μ s to 355 s with 800-point trace
Trigger Free run, line, video, external	
IF resolution bandwidth	10 Hz to 300 kHz (HP 70902A) 100 kHz to 3 MHz (HP 70903A) 1, 3, 10 sequence and 10% increments except 3 kHz to 10 kHz
Accuracy	$\pm 20\%$
Selectivity (-60 dB/-3 dB)	
<input type="checkbox"/> 10 Hz to 3 kHz	< 12:1 (5-pole, synchronously tuned)
<input type="checkbox"/> 10 kHz to 3 MHz	< 16:1 (4-pole, synchronously tuned)
Video bandwidth	
Range	3 Hz to 300 kHz (HP 70902A) 300 Hz to 3 MHz (HP 70903A) 1, 3, 10 sequence
Accuracy	20% (characteristic)
Set to maximum bandwidth	> 300 kHz (HP 70902A) > 4.5 MHz (HP 70903A)

¹⁴ N is the harmonic mixing number; N=1 from 100 Hz to 6.2 GHz, N=2 from 6.0 to 12.8 GHz, N=4+ from 12.6 to 26.5 GHz.

Signal Analyzers

Wide Bandwidth Receiver

HP 71910A/P

Amplitude

Total amplitude range -138 to ± 30 dBm

Displayed average noise level

(10 Hz res. BW; 0 dB attenuation; 3 Hz video BW; ref. level < -75 dBm)	Frequency	DANL
	100 Hz	< -92 dBm (char)
	300 Hz	< -95 dBm (char)
	1 kHz	< -101 dBm (char)
	3 kHz	< -111 dBm (char)
	10 kHz	< -118 dBm (char)
	30 kHz	< -118 dBm (char)
	100 kHz	< -122 dBm (char)
	300 kHz	< -130 dBm (char)
	1 MHz	< -139 dBm (char)
	3 MHz	< -139 dBm (char)
	10 MHz to 2.0 GHz	< -138 dBm
	2.0 to 12.8 GHz	< -137 dBm
	12.6 to 22.0 GHz	< -130 dBm
	22.0 to 26.5 GHz	< -128 dBm
with HP 70620B (Option 016/017)	1.0 to 12.8 GHz	-155 dBm
	12.6 to 22.0 GHz	-150 dBm
	22.0 to 26.5 GHz	-148 dBm

Gain compression level

(10 dB input attenuation) ≤ 0.5 dB for signal levels ≤ 0 dBm

Spurious response

(Except as listed below, for < -30 dBm total signal power at the RF input with 10 dB attenuation)

(preselector on) 10 MHz to 26.5 GHz < -70 dBc

Second harmonic distortion

(preselector on) 100 Hz to 20 MHz < -60 dBc
20 MHz to 2.9 GHz < -75 dBc
2.9 to 26.5 GHz < -100 dBc

Third order intermodulation

(For two signals each ≤ -20 dBm at the RF input, 10 dB attn, 20 to 30° C)

HP 70902A	Center frequency	Intermod. Products	Equiv. TOI
	100 Hz to 20 MHz	< -64 dBc	+2 dBm
	20 MHz to 2.9 GHz	< -78 dBc	+9 dBm
	2.7 to 6.2 GHz	< -68 dBc	+4 dBm
	6.0 to 26.5 GHz	< -64 dBc	+2 dBm

(For two signals each ≤ -15 dBm at the RF input, 10 dB attn, 20 to 30° C)

HP 70903A	Center frequency	Intermod. Products	Equiv. TOI
	100 Hz to 20 MHz	< -54 dBc	+2 dBm
	20 MHz to 2.9 GHz	< -68 dBc	+9 dBm
	2.7 to 6.2 GHz	< -58 dBc	+4 dBm
	6.0 to 26.5 GHz	< -54 dBc	+2 dBm

Image response (RF input ≤ 0 dBm, attenuation ≥ 10 dB)

6 MHz	< -85 dBc
42.8 MHz	< -85 dBc
642.8 MHz	See image rejection specifications for collection receiver

Residual responses

(0 dB attenuation; input terminated)	Range	Responses
	10 MHz to 26.5 GHz	< -100 dBm

Multiple and out of band responses

(for inputs ≤ 26.5 GHz and RF levels ≤ 0 dBm, ≥ 10 dB attenuation, preselector on)

Display range	10 divisions
Scale (log)	0.01 to 20 dB/div in 0.5% increments
Scale (linear)	10% of ref. level per division
Reference level (log)	+30 to -140 dBm
Reference level (linear)	7.07 to 22 nV

Frequency response (10 dB atten., preselector peaked)

Frequency range	0 to 55° C	20 to 30° C	0 to 55° C
	Peak variation	Ref. to calibrator ¹⁵	Ref. to calibrator ¹⁵
100 Hz to 2.9 GHz	± 1.5 dB	± 2.0 dB	± 2.0 dB
2.7 to 6.2 GHz	± 2.0 dB	± 2.0 dB	± 3.0 dB
6.0 to 12.8 GHz	± 2.0 dB	± 2.0 dB	± 3.0 dB
12.6 to 22.0 GHz	± 2.0 dB	± 2.0 dB	± 3.5 dB
22.0 to 26.5 GHz	± 2.5 dB	± 2.5 dB	± 4.0 dB

(preset preselector DAC, 20 to 30° C, ref to calibrator¹⁵)

2.7 to 22.0 GHz +2.0, -3.0 dB (characteristic)

22.0 to 26.5 GHz +2.5, -3.5 dB (characteristic)

(for spans ≤ 100 MHz)

Input attenuator

Range 0 to 65 dB in 5 dB steps
Switching repeatability ± 0.2 dB
Accuracy, referenced to 10 dB setting (characteristic)

<input type="checkbox"/> 0 to 2.9 GHz	± 1.2 dB
<input type="checkbox"/> 2.9 to 12.7 GHz	± 2.3 dB
<input type="checkbox"/> 12.7 to 19.9 GHz	± 2.8 dB
<input type="checkbox"/> 19.9 to 26.5 GHz	± 4.8 dB

Preselector bypass switch repeatability ± 0.2 dB

IF gain accuracy	Gain	20 to 30° C	0 to 55° C
HP 70902A	10 dB	± 0.2 dB	± 0.2 dB
	20 dB	± 0.2 dB	± 0.2 dB
	30 dB	± 0.2 dB	± 0.5 dB
	50 dB	± 0.2 dB	± 0.6 dB
	60 dB	± 0.4 dB	± 0.8 dB
HP 70903A	10 dB	± 0.1 dB	± 0.1 dB
	20 dB	± 0.3 dB	± 0.3 dB

¹⁵ Referenced to 300 MHz -10 dBm calibrator. Does not include ± 0.3 dB $\Delta 6$ calibrator amplitude error.

Signal Analyzers

Wide Bandwidth Receiver

HP 71910A/P

Specifications

Scale fidelity		
Log (corrected)	<i>Bandwidth</i>	<i>Fidelity</i>
<input type="checkbox"/> HP 70902A	< 30 Hz	± 0.7 dB
<input type="checkbox"/> (0 to 90 dB)	30 Hz to 100 kHz	± 0.5 dB
	> 100 kHz	± 0.7 dB
<input type="checkbox"/> HP 70903A	≥ 1 MHz	± 0.5 dB
<input type="checkbox"/> (0 to 75 dB)	≥ 1 MHz	± 3.0 dB
Log (uncorrected)	all	
Incremental fidelity	0.1 dB/dB, all bandwidths	
Linear	± 7.5% of reference level	
Amplitude temperature		
Drift (characteristic)	± 0.05 dB/°C at 300 MHz	
-10 dBm ref. level, 10 dB input atten	100 Hz res. BW (HP 70902A) 300 kHz res. BW (HP 70903A)	
Res BW switching repeatability		
	± 0.2 dB in 1, 3, 10 sequence ± 3 dB (uncorrected)	
Marker resolution		
	± 0.03 dB	
Inputs and outputs		
HP 70902A IF section		
Auxiliary video output	BNC (f), 0 to 1 V, 1 kΩ (nominal)	
3 MHz IF output (linear)	BNC (f), 50 Ω < 1.5:1 VSWR (characteristic)	
Output level	-15 dBm (nominal) with -10 dBm at RF input 0 dB atten., -10 dBm ref. level	
HP 70903A IF section		
Auxiliary video output	BNC (f), 0 to 1 V, 100 Ω (nominal)	
21.4 MHz IF output (linear)	BNC (f), 50 Ω < 1.5:1 VSWR (characteristic)	
Output level	-15 dBm (nominal), -10 dBm ref. level	

General

HP 71910A system components	HP 71910P system components
<input type="checkbox"/> HP 70001A mainframe	<input type="checkbox"/> HP 70001A mainframe
<input type="checkbox"/> HP 70004A display/mainframe	<input type="checkbox"/> HP 70207B E05 PC display for MMS
<input type="checkbox"/> HP 70900B Option 512 local oscillator (2 slots)	<input type="checkbox"/> HP 70900B Option 512 local oscillator (2 slots)
<input type="checkbox"/> HP 70310A precision frequency reference (1 slot)	<input type="checkbox"/> HP 70310A precision frequency reference (1 slot)
<input type="checkbox"/> HP 70902A IF section (1 slot)	<input type="checkbox"/> HP 70903A IF section (1 slot)
<input type="checkbox"/> HP 70903A IF section (1 slot)	<input type="checkbox"/> HP 70910A wide bandwidth RF section (2 slots)
<input type="checkbox"/> HP 70910A wide bandwidth RF section (2 slots)	<input type="checkbox"/> HP 70911A ultrawide bandwidth IF section (2 slots)
<input type="checkbox"/> HP 70911A ultrawide bandwidth IF section (2 slots)	<input type="checkbox"/> HP 70911A ultrawide bandwidth IF section (2 slots)

Note: When adding or exchanging modules, be sure that the final count will fit into 8-slot HP 70001A mainframe or 4-slot HP 70004A display/mainframe.

Note: For HP 71910P only, the HP 70902A IF section has been removed to provide a single mainframe configuration.

Environmental	
Temperature	0 to 55°C, operational -40 to +75°C, storage
Humidity	0 to 95% relative humidity at 45°C, operational
EMC	Conducted and radiated interference is in compliance with CISPR publication 11, FTZ 526/1979, and MIL-STD 461B, RE02/part 7.
Power requirements	
(characteristic)	404 W
Weight, standard system	
(nominal)	55.6 kg (122.3 lb)
Dimensions	
HP 70001A mainframe	177 mm (7 in) high, 426 mm (16.75 in) wide, 526 mm (20.7 in) long
HP 70004A display/mainframe	222 mm (8.7 in) high, 426 mm (16.75 in) wide, 526 mm (20.7 in) long
Calibration cycle	
	3 years recommended

Signal Analyzers

Wide Bandwidth Receiver

HP 71910A/P

Ordering Information

HP 71910A wide bandwidth receiver

- Option 001** 70 MHz IF output
- Option 002** 140 MHz IF output
- Option 004** analog I/Q output
- Option 005** FM output
- Option 007** 70 MHz IF channel filters (requires Opt. 001)
- Option 011** single mainframe configuration (deletes HP 70004A, 70902A, 70903A, 70310A)
- Option 012** add HP 70310A to Option 011 configuration
- Option 013** add HP 70902A to Option 011 configuration
- Option 014** add HP 70903A to Option 011 configuration
- Option 016** add HP 70620B Option 001 preamplifier (100 kHz to 26.5 GHz)
- Option 017** add HP 70620B preamplifier (1 to 26.5 GHz)
- Option 100** delete HP 70902A from standard configuration
- Option 101** delete HP 70903A from standard configuration
- Option 110** delete HP 70310A precision frequency reference from standard configuration
- Option 121** add distribution amplifier to HP 70310A
- Option 122** delete ovenized oscillator in HP 70310A
- Option 200** delete HP 70004A display/mainframe
- Option 400** add 400 Hz power line frequency operation to HP 70001A mainframe
- Option 660** add HP 8566B programming manual set

HP 71910P wide bandwidth receiver

- Option 001** 70 MHz IF output
- Option 002** 140 MHz IF output
- Option 004** analog I/Q output
- Option 005** FM output
- Option 007** 70 MHz IF channel filters (requires Opt. 001)
- Option 008** replace HP 70903A with HP 70902A
- Option 009** add HP 70902A and HP 70001A mainframe
- Option 010** add HP 70001A mainframe
- Option 016** add HP 70620B Option 001 preamplifier (100 kHz to 26.5 GHz)
- Option 017** add HP 70620B preamplifier (1 to 26.5 GHz)
- Option 110** delete HP 70310A precision frequency reference from standard configuration
- Option 121** add distribution amplifier to HP 70310A
- Option 122** delete ovenized oscillator in HP 70310A
- Option 660** add HP 8566B programming manual set

Compatible accessory modules and analysis tools

Oscilloscopes	HP 70703A, 20 MS/s HP 54610A, 20 MS/s HP 54720D, 4 GS/s HP 54542A, 2 GS/s
Digitizer	HP 70700A, 20 MS/s
Power meter	HP 70100A, -70 to +4 dBm
Attenuator/switch driver	HP 70611A
Interface modules	HP 70612A/C, 70613A/C
Custom switching	Call your HP sales representative
Vector signal analyzer	HP 89410A; dc to 10 MHz
Baseband signal analyzer	HP 3587S, dc to 4 MHz
Modulation domain analyzers	HP 5371A, 5372A, 5373A, 53310A
RAM card	HP 82215A (128 K), HP 85700A (32 K)
MATE module	HP 70590A/H69 and H72

Software

Receiver personality included with HP 71910A/P
HP 11990A performance verification software

Additional Information

Product Overviews (3)

HP 71910A/P Wide Bandwidth Receiver

part no. 5965-7916E

Test Solutions for Satellite Manufacturers

part no. 5965-6195E

Power Solutions to Complex Measurement Problems

part no. 5965-8554E

Configuration Guide

HP 71910A Wide Bandwidth Receiver

part no. 5964-4351E

Product Note

Extending Vector Signal Analysis to 26.5 GHz with 20 MHz Information Bandwidth (89400-13)

part no. 5964-3586E

Spectrum Analyzers

HP 70000 Series

Overview

Outstanding RF and microwave performance

HP 71100C/P 100 Hz–2.9 GHz
HP 71200C/P 50 kHz–22 GHz
HP 71209A/P 100 Hz–26.5 GHz
HP 71210C/P 100 Hz–22 GHz

Speed, precision, and flexibility

Modern feature set

3-year recommended calibration interval

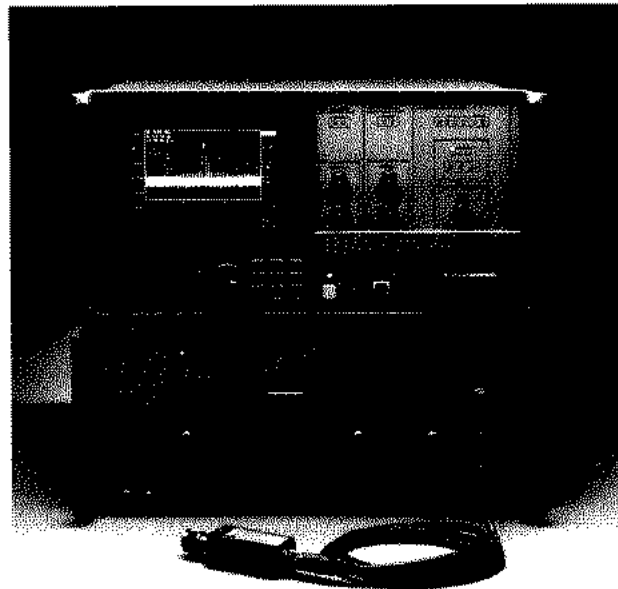

HP 70000 Series

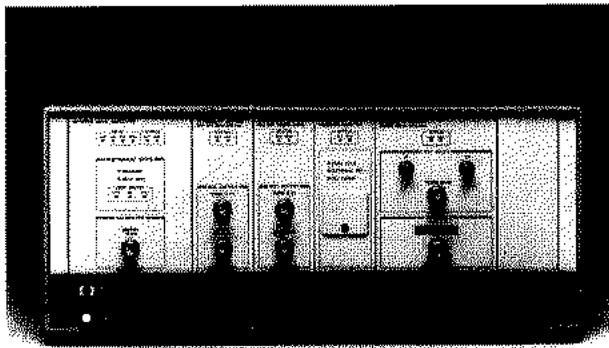

HP 71209P (PC not shown)

Four standard spectrum analyzer systems

Four standard spectrum analyzer systems cover the frequency range from RF to microwave. The HP 71100C/P provides coverage from 100 Hz to 2.9 GHz; the HP 71200C/P, from 50 kHz to 22 GHz; the HP 71209A/P from 100 Hz to 26.5 GHz; and the HP 71210C/P, from 100 Hz to 22 GHz. Adding the HP 70907B external-mixer-interface module to any of these spectrum analyzers provides millimeter frequency coverage to 325 GHz. (External mixer capability is included in the standard HP 71209A/P system.)

With these spectrum analyzers, you can customize your test equipment and expand your system as your needs change.

Features common to all HP 70000 spectrum analyzers are described below. Information about the performance of individual models follows this section.

Full-color display and hardkey panel or PC display

All A/C systems include the HP 70004A, a state-of-the-art color display and mainframe. A custom hardkey panel for spectrum analysis comes installed in each HP 70004A ordered as part of a spectrum analyzer system. The P systems include the HP 70207B E05 PC display for MMS.

Amplitude accuracy

You can measure amplitude anywhere within the 90 dB calibrated display range. Excellent display fidelity makes IF substitution unnecessary. Accurate measurements can be made quickly using the built-in marker functions. For even greater accuracy, add the HP 70100A power meter to your instrument workstation.

Frequency accuracy

For 0.1 ppm frequency accuracy and stability over both temperature and time, an oven-controlled reference oscillator is standard in these synthesized analyzers. A 10 MHz output and optional distribution amplifiers allow other instruments in your system to be locked to the same reference.

Spectrum Analyzers

HP 70000 Series

Overview

Applications

Radar

Now you can have all the advantages of a digital display—such as trace storage, plotting, and printing—without losing the benefits of an analog display. Digital persistence in the spectrum analyzer simulates the characteristics of an analog display for viewing multiple signal patterns. For example, now you can view, measure, and record double-pulse output from a radar transmitter.

In zero-span mode, the analyzer becomes a fixed-tuned receiver, allowing you to demodulate the measured signal and view the pulses. Adding an HP 70700A digitizer decreases the minimum sweep time to 80 μ s in zero span. This enables you to view fast rise-time pulses (logged amplitude) while retaining the benefits of the digital display.

Component test

Two tracking generators are available for scalar-analysis measurements. Add an HP 70300A (20 Hz to 2.9 GHz) for 124 dB dynamic range. Or, add an HP 70301A (2.7 GHz to 18 GHz) and get 130 dB dynamic range. The tracking generators operate together to provide continuous sweeps from 10 MHz to 18 GHz.

A downloadable program (DLP) adds a scalar-network-analysis personality, which provides a user interface for making transmission or reflection measurements, and open-short and through normalization. You can enter limit lines for upper and lower test boundaries, and a pass/fail indicator is provided.

Communications

The HP 70000 spectrum analyzers have 117 Hz/GHz frequency accuracy, which allows you to measure closely spaced communication channels with ease. The low phase noise of the spectrum analyzers also permits close-in testing of low-level spurious

signals in transmitters. As communication bands extend to higher frequencies, you can convert your RF system to microwave simply by replacing the RF section. This saves you the cost of a new spectrum analyzer and the need for training on a new system.

High-level firmware allows you to make measurements faster and more easily. It simplifies many procedures and provides useful information, not just data. Here are just a few examples:

Fast Fourier Transform (FFT) measures close-in, low-level AM sidebands and eliminates the effects of incidental FM.

Peaks measures and sorts, in order of frequency or amplitude, the signals on the display for signal-monitoring applications.

PWRBW measures the occupied-power bandwidth of the signal on the display for narrowband FM signal analysis.

All of these high-level firmware features are accessed via downloadable programs (described on the next page) or with a controller.

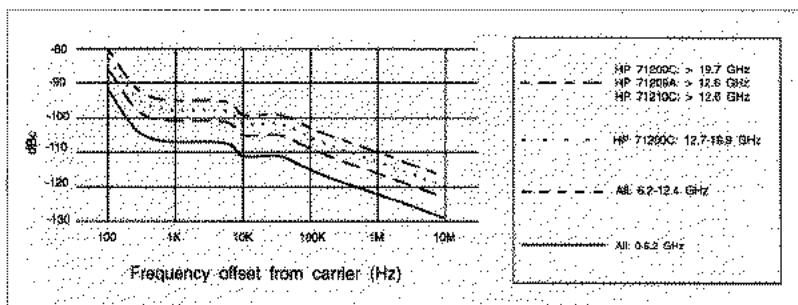
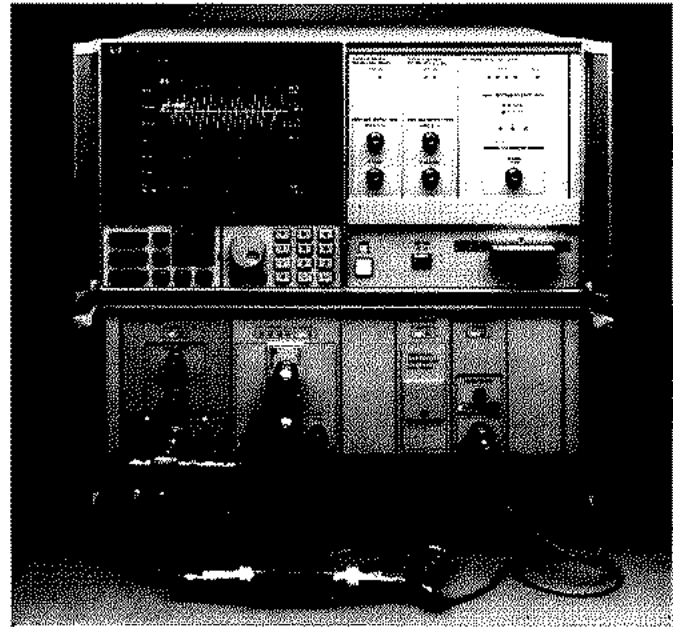

Figure 1. Typical local oscillator phase noise sidebands at offsets from 100 Hz to 10 MHz.

Spectrum Analyzers

HP 70000 Series

Overview

Spurious tests and surveillance

Spurious tests and surveillance applications both require an analyzer with high sensitivity. The HP 70000 analyzers offer sensitivity of about -134 dBm to 2.9 GHz. This range can be improved even more with the addition of the HP 70621A or 70620B preamplifiers. Sensitivity of -156 dBm is achieved by the HP 71100C/P and HP 70621A combination, and sensitivity of -150 dBm by the HP 71210C/P and HP 70620B combination.

External mixer interface

For measurements above 26.5 GHz, the HP 70907B external mixer interface can be added to any system or used without an RF section for millimeter-only spectrum analysis. Full capability (described in the Millimeter Measurement System section) is available for measurements to 75 GHz with preselection or to 325 GHz without preselection.

Digital persistence display

Digital persistence in the HP 70004A color display allows you to extract information from complex modulated signals such as TV, pulsed RF, and FM.

Digital persistence simulates the variable intensities of analog displays, without sacrificing the storage and plotting capabilities of digital displays.

Automatic test systems

The HP 70900B local oscillator module contains a high-speed microprocessor for trace data manipulation and spectrum analyzer tuning control. Additional high-level functions simplify programming requirements to save you time and money.

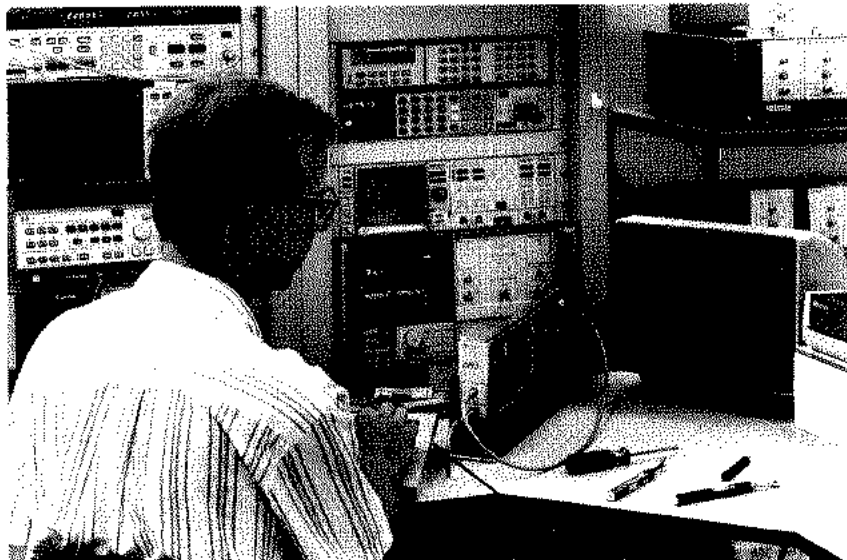

Save rack space and money

You can save valuable rack space in ATE systems by eliminating the display and controlling the analyzer over the HP-IB. In a standard system, this cuts rack space by more than one half. For occasional troubleshooting, you can roll a display up to your test system. Option 200 deletes the display and saves you money, too.

Downloadable programs

For use without a computer, the spectrum analyzer can control other instruments via the HP-IB to make complex measurements and display results. The remote programming language is easy to read and simple to use. It enables you to create an automatic test workstation without an external computer.

Mass storage

These systems access external mass-storage devices such as HP-IB disk drives and memory cards (via the HP 70004A display), or the internal memory of the spectrum analyzers. Instrument states, traces, and downloadable programs are easily stored or recalled.

Minimal cost-of-ownership

The analyzers have a three-year calibration cycle, which means that your test equipment uptime increases while service costs are less. Based on customer data from past years, cost of ownership per year amounts to less than 1.5% of the list price. (This assumes an average 2,000 hours per year operation and accounts for average repair and calibration costs over the time period.)

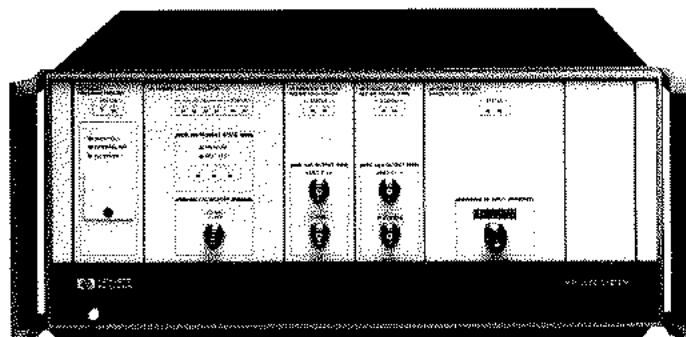

Spectrum Analyzers

HP 70000 Series

HP 71100C/P

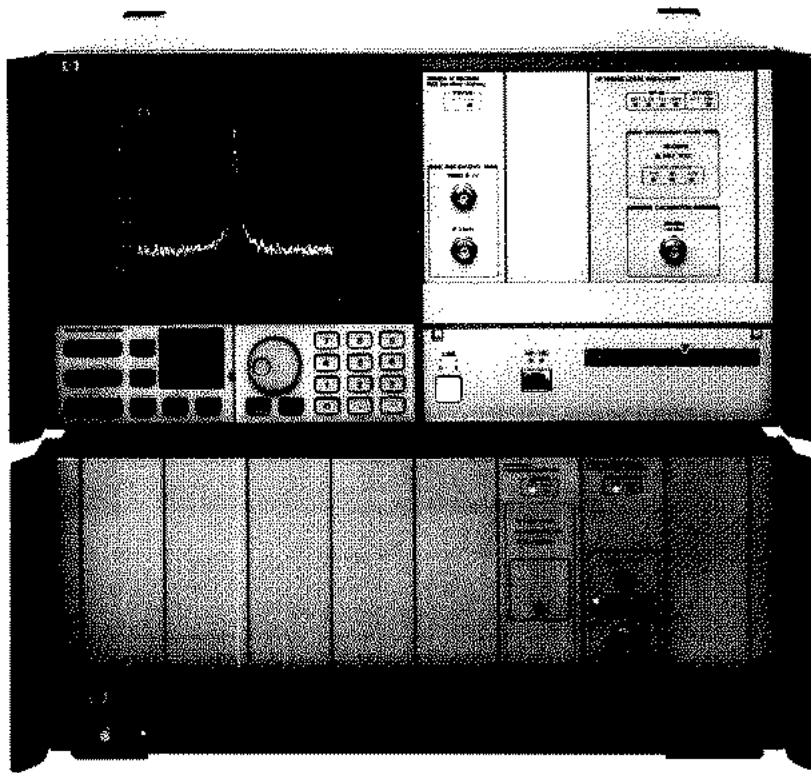

100 Hz to 2.9 GHz

Synthesized, high performance spectrum analyzer

10 Hz minimum bandwidth

-134 dBm sensitivity

The HP 71100C/P is a high performance RF spectrum analyzer operating from 100 Hz to 2.9 GHz. Its synthesized performance offers very precise, high-speed tuning for use in the lab and manufacturing and in integrated test systems. Excellent sensitivity, phase noise, and dynamic range allow you to make even the most demanding RF measurements.

Along with general characteristics described in the HP 70000 spectrum analyzer overview, the HP 71100C/P offers some special features. The RF input can be either ac or dc coupled. The ac-coupling prevents damage to the input attenuator due to a dc signal applied to the input. It also has a probe power supply input for a high-impedance probe. Attaching a probe allows you to measure signals directly from a printed circuit board.

The HP 71100C/P fits into a wide range of RF communication applications. You can measure harmonic, third order distortion, and other spurious from RF radios, pagers, and other transmitters; from receivers; or from their components. You can also use the analyzer for fast surveillance applications.

Other systems based on HP 71100C/P modules are the component test system using tracking generators and the lightwave signal analyzer. The HP 71100C/P spectrum analyzer can be used with the HP 70907B external mixer interface to measure millimeter signals. Additional accessory modules that are compatible include the HP 70621A and HP 70620B preamplifiers for sensitivity improvement to -156 dBm and the HP 70700A digitizer for 80 ms sweeps in zero span.

HP 71100C/P spectrum analyzer basic configuration

When size or cost is a concern, and when absolute frequency accuracy is not required, two delete options provide an attractive, basic RF spectrum analyzer. With Option 110 (delete the HP 70310A precision frequency reference), all required modules fit into the HP 70004A color display. Option 201 deletes the HP 70001A mainframe, resulting in a smaller system package for an outstanding price.

The HP 71100P is a single mainframe with the display on a PC. The 71100P includes the HP 70207B E05 PC display for MMS. Key features are manual and automatic control of MMS instrumentation using a PC; capability for output to PC printers and mass storage devices; and lower system costs.

Spectrum Analyzers

HP 70000 Series

HP 71100C/P

This configuration (shown at right) has all the features and amplitude performance of the complete HP 71100C/P spectrum analyzer. Without the precision frequency reference, frequency drift—and therefore absolute frequency accuracy—is degraded. However, sweep linearity and relative frequency accuracy are not affected, so you have full confidence in all relative measurements.

Should your needs change in the future, the HP 70310A precision frequency reference can be added at any time. (With Option 201, a slot no longer available for this module, so a mainframe would then be required.)

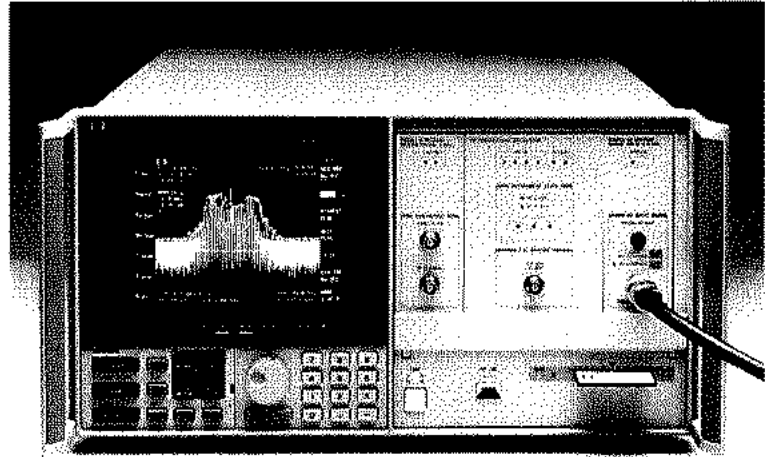

Specifications

Specifications describe the instrument's warranted performance over the 0° C to +55° C temperature range. Characteristics provide information about non-warranted instrument performance. Nominal values indicate the expected value of the parameter. All specifications apply after the instrument's temperature has been stabilized after a one-hour warm-up, self-calibration routines have been run, and the preselector peak function has been executed. Where specifications are subject to minimization with error correction routines, corrected limits are given unless noted.

HP 71100C/P RF Spectrum Analyzer	
100 Hz to 2.9 GHz	
Frequency	
Frequency range	100 Hz–2.9 GHz (dc coupled) 100 kHz–2.9 GHz (ac coupled) Tunable in 1 Hz increments
Frequency readout accuracy	
Span ≤ 10 MHz	± [(freq readout x freq ref accuracy) + 1.0% of span + 10 Hz]
Span > 10 MHz	
Sweep ≥ 20 ms	± [(freq readout x freq ref accuracy) + 1.5% of span + 10 Hz]
Sweep ≥ 10 ms	± [(freq readout x freq ref accuracy) + 2.5% of span + 10 Hz]
Frequency span	
Range	1 Hz–2.9 GHz in 0.5% increments and 0 Hz
Accuracy	
Span ≤ 10 MHz	± [1% of span + (span x freq ref accuracy)]
Span > 10 MHz	
Sweep ≥ 50 ms	± [1.5% of span + (span x freq ref acc)]
Sweep ≥ 20 ms	± [2.5% of span + (span x freq ref acc)]
Sweep ≥ 10 ms	± [4.0% of span + (span x freq ref acc)]
Frequency reference accuracy	
	w/ HP 70310A w/o HP 70310A
Aging	< 1x10 ⁻⁷ /year, < 3x10 ⁻⁶ /year < 5x10 ⁻¹⁰ /day (7-day avg.)
Temperature drift	< 7x10 ⁻⁹ < 1x10 ⁻⁵

HP 71100C/P RF Spectrum Analyzer	
Spectral purity¹	
Noise sidebands at 10 kHz Offset	< -108 dBc/Hz
Line and system related sidebands	< -65 dBc
Residual FM	
Span > 10 MHz	< 25 kHz p-p in 0.1 s (measurement BW=100 kHz)
Span ≤ 10 MHz	Determined from phase-noise sidebands
Frequency drift	
	For spans > 10 MHz, freq drift is ±1 kHz/s and ±150 kHz/°C. Errors due to drift are not cumulative sweep to sweep.
Sweep time	
Range (continuous)	10 ms to 1000 s
Accuracy	±2%
with HP 70700A	Swept freq span: 15 ms–355 s Fixed freq (zero span): 80 μs–355 s with 800 trace points
Trigger	
	Free run, line, video, external
Resolution bandwidth (3 dB, synchronously tuned)	
Range	10 Hz–300 kHz (HP 70902A); (1, 3, 10 sequence and 10 % increments except 3 kHz–10 kHz)
	100 kHz–3 MHz (HP 70903A)
Accuracy	± 20%
Selectivity (-60 dB/-3 dB) bandwidth	
10 Hz–3 kHz	< 12:1
10 kHz–3 MHz	< 16:1

¹ Refer to Figure 1 in the Spectrum Analyzer Overview for typical phase noise.

Spectrum Analyzers

HP 70000 Series

HP 71100C/P

Amplitude			
Total amplitude range	-134 to +30 dBm		
Maximum safe input power			
AC average continuous	+30 dBm (≥ 10 dB attn)		
Pulse power	100 W, 10 ms pulse (≥ 20 dB attn)		
DC	0 V; ± 25 V in ac mode		
Displayed average noise level (0 dB attn)			
	<i>Band</i>	<i>DANL</i>	
10 Hz res BW	10 MHz–2.0 GHz	< -134 dBm	
	2.0 GHz–2.9 GHz	< -131 dBm	
with HP 70621A	10 MHz–2.9 GHz	< -156 dBm	
100 kHz res BW	For freq > 1 MHz, displayed average noise level is 40 dB higher than the above.		
Gain compression level			
0 dB input attn	< 0.5 dB for signal levels ≤ -10 dBm		
Spurious responses			
	<i>Input</i>	<i>Spurious</i>	
For mixer level ≤ -40 dBm	100 Hz–10 MHz	< -60 dBc	
All spurious responses, except as listed below, are less than these values (10 dB attn)	10 MHz–2.9 GHz	< -70 dBc	
Second harmonic distortion	<i>Band</i>	<i>Second harmonic</i>	
<input type="checkbox"/> For mixer level ≤ -40 dBm	100 Hz–10 MHz	< -60 dBc	
<input type="checkbox"/> (10 dB attn)	10 MHz–2.9 GHz	< -70 dBc	
Third order intermodulation	<i>Center frequency</i>	<i>Intermod products</i>	<i>Equiv TOI</i>
Distortion for two signals each ≤ -30 dBm at mixer (10 dB attn)	100 Hz–10 MHz	< -66 dBc	+3 dBm
	10 MHz–2.9 GHz	< -70 dBc	+5 dBm
Image responses	≤ -90 dBc for RF input levels ≤ 0 dBm at 6, 42.8, and 642.8 MHz offset (10 dB attn)		
Residual responses			
(0 dB input attn with input terminated)	<i>Range</i>	<i>Responses</i>	
	10 MHz–2.9 GHz	< -100 dBm	
Display range (10 divisions)			
Calibration			
<input type="checkbox"/> Log	0.01 to 20 dB/div in 0.5% increments		
<input type="checkbox"/> Linear	0 to 10% of reference level per division		
Reference level range			
<input type="checkbox"/> Log	+30 to -140 dBm		
<input type="checkbox"/> Linear	7.07 V to 22 nV		
Frequency response			
	<i>Band</i>	<i>Variation</i>	
<input type="checkbox"/> Peak variation (10 dB attn)	100 Hz–2.5 GHz	± 1.0 dB	
	100 Hz–2.9 GHz	± 1.5 dB	
<input type="checkbox"/> Referenced to 300 MHz, -10 dBm calibrator (10 dB attn)	100 Hz–2.5 GHz	± 1.3 dB	
	100 Hz–2.9 GHz	± 1.8 dB	
Calibrator uncertainty	+0.3 dB (-10 dBm, 300 MHz)		

Amplitude			
Input attenuator switching repeatability	± 0.2 dB		
IF gain accuracy	<i>Gain</i>	<i>20 to 30° C</i>	<i>0 to 50° C</i>
	10 dB	± 0.2 dB	± 0.2 dB
	20 dB	± 0.2 dB	± 0.2 dB
	30 dB	± 0.2 dB	± 0.3 dB
	40 dB	± 0.2 dB	± 0.5 dB
	50 dB	± 0.2 dB	± 0.6 dB
Scale fidelity			
	<i>Bandwidth</i>	<i>Fidelity</i>	
Log, corrected (1-3-10)			
<input type="checkbox"/> HP 70902A	10 Hz	± 0.7 dB	
<input type="checkbox"/> (0 to 90 dB)	30 Hz–100 kHz	± 0.5 dB	
	300 kHz	± 0.7 dB	
Log, uncorrected			
<input type="checkbox"/> Incremental, corrected	All	± 3.0 dB	
<input type="checkbox"/> Linear	All	± 0.1 dB/1 dB	
Amplitude temperature			
Drift (nominal)	± 0.05 dB/°C		
-10 dBm ref level, 10 dB input attn, 100 Hz res BW (HP 70902A IF)	(Accumulated error is eliminated by running internal correction routine)		
300 kHz res BW (HP 70903A IF)			
Resolution bandwidth switching repeatability			
In 1, 3, 10 sequence	± 0.2 dB		
All bandwidths	± 3 dB (uncorrected)		
Marker resolution	± 0.03 dB		
Input/output characteristics			
Front panel (see individual module specs for complete information)			
HP 70900B			
<input type="checkbox"/> 300 MHz calibrator output	BNC (f), 50 Ω (nominal)		
<input type="checkbox"/> Output power	-10 dBm ± 0.3 dB		
<input type="checkbox"/> Frequency accuracy	300 MHz x freq ref accuracy		
HP 70904A			
<input type="checkbox"/> RF input (100 Hz–2.9 GHz)	Type-N (f), 50 Ω (nominal), < -100 dBm (nominal)		
	LO emissions (10 dB attn)		
	VSWR (310 dB attn)	< 1.3:1 (nominal)	
	VSWR (0 dB attn)	< 2.9:1 (nominal)	
<input type="checkbox"/> Probe power output	+15 V, -12 V and ground, 150 mA maximum		
HP 70902A Auxiliary video output			
3 MHz IF output (Linear)	BNC (f), 0–1 V, 1 k- Ω (nominal)		
	BNC (f), 50 Ω , 1.5:1 VSWR (nominal)		
Output power			
	-15 dBm nominal with -5 dBm RF input, 0 dB attn and -10 dBm ref lvl		
HP-IB codes			
	SH1 AH1 T6 L4 SR1 RL1 DC1 PPO DT1 E2 C1		

Spectrum Analyzers

HP 70000 Series

HP 71100C/P

General Specifications

HP 71100C system components	HP 71100P system components
<input type="checkbox"/> HP 70001A	<input type="checkbox"/> HP 70001A
<input type="checkbox"/> HP 70004A	<input type="checkbox"/> HP 70207B E05
<input type="checkbox"/> HP 70900B	<input type="checkbox"/> HP 70900B
<input type="checkbox"/> HP 70310A	<input type="checkbox"/> HP 70310A
<input type="checkbox"/> HP 70902A	<input type="checkbox"/> HP 70902A
<input type="checkbox"/> HP 70904A	<input type="checkbox"/> HP 70904A

(Note: When adding or exchanging modules, be sure that the final module count will fit into the 8-slot HP 70001A mainframe and the 4-slot HP 70004A display/mainframe.)

Environmental temperature	Operational, 0 to +55° C Storage, -40 to +75° C
Humidity	Operational, 0 to 95% relative humidity at 45° C
EMC	Conducted and radiated interference is in compliance with CISPR pub 11, FTZ 526/1979, and MIL-STD 461B, RE02/part 7.
Vibration and shock	In compliance with MIL-T-28800E Type III Class 3
Power requirements	See requirements for HP 70001A and HP 70004A. All power requirements supplied by the mainframe (HP 70001A or 70004A).
Weight (nominal), HP 71100C/P standard	48 kg (105.8 lb)
Dimensions	
HP 70001A mainframe	177.0 mm (6.97") high, 425.4 mm (16.75") wide, 526.0 mm (20.7") long
HP 70004A display	222.0 mm (8.74") high, 425.4 mm (16.75") wide, 526.0 mm (20.7") long
Warranty	1 year (extendible with options)
Calibration cycle	3 years recommended

Features and compatibility

HP 70004A display features used	memory card, direct-to-disk, keyboard (for title mode and writing small DLPs), direct plot (buffered), direct print, full color display
Mass storage	
Memory card	32 KB or 128 KB RAM per card
External	SS80-compatible hard or flexible disk
User memory	32 KB minimum 128 K with 901008 firmware. About 2.5 KB to store an 800 point trace with its state. System memory is reduced when slave modules are added.

Compatible accessory modules

(slave modules to the HP 70900B master module)

- HP 70903A IF section
- HP 70621A/HP 70620B preamplifiers
- HP 70300A/HP 70301A tracking generators
- HP 70810B lightwave section
- HP 70907B external mixer interface module
- HP 70700A digitizer (in slave mode)
- HP 70205A monochrome display

Software available from HP

- HP 11990A performance verification software
- HP 70871A scalar measurement personality

Ordering Information

HP 71100C/P spectrum analyzer

Option 1BH general export license version, limit span to 2.3 GHz

Option 1BN certificate of calibration

Option 1BP certificate of calibration and data

Option W30 two additional years of return-to-HP warranty (3 years total)

Option 006 delete HP 70902A 10 Hz–300 kHz IF section

(NOTE: HP 70903A 100 kHz–3 MHz IF section must be ordered)

Option 110 delete HP 70310A precision frequency reference

Option 121 add distribution amplifier on the HP 70310A precision frequency reference (HP 70310A/001)

Option 122 provide external reference capability and delete ovenized reference in the HP 70310A

Option 200 delete display (operation and control over HP-IB only)

Option 201 delete mainframe

(NOTE: count modules to ensure fit in mainframe)

Option 205 substitute HP 70205A display for HP 70004A display/mainframe

Option 400 add 400 Hz power line frequency operation to the HP 70001A mainframe; add isolation transformer at 2.3 kg (5 lb) (HP 71100C only)

Option 512 additional memory, 1 Mbyte total, 90 KB user memory

Option 810 rack mount slide kit for both the HP 70001A mainframe and the HP 70004A display/mainframe

Option 908 rack flange kit to mount HP 70001A/HP 70004A without handles

Option 910 extra user manual set containing (a) installation/ verification, (b) operation, and (c) program language reference

Option 913 rack flange kit to mount HP 70001A/HP 70004A with handles attached

Option 915 service manual set and software for troubleshooting and repair

Spectrum Analyzers

HP 70000 Series

HP 71200C/P

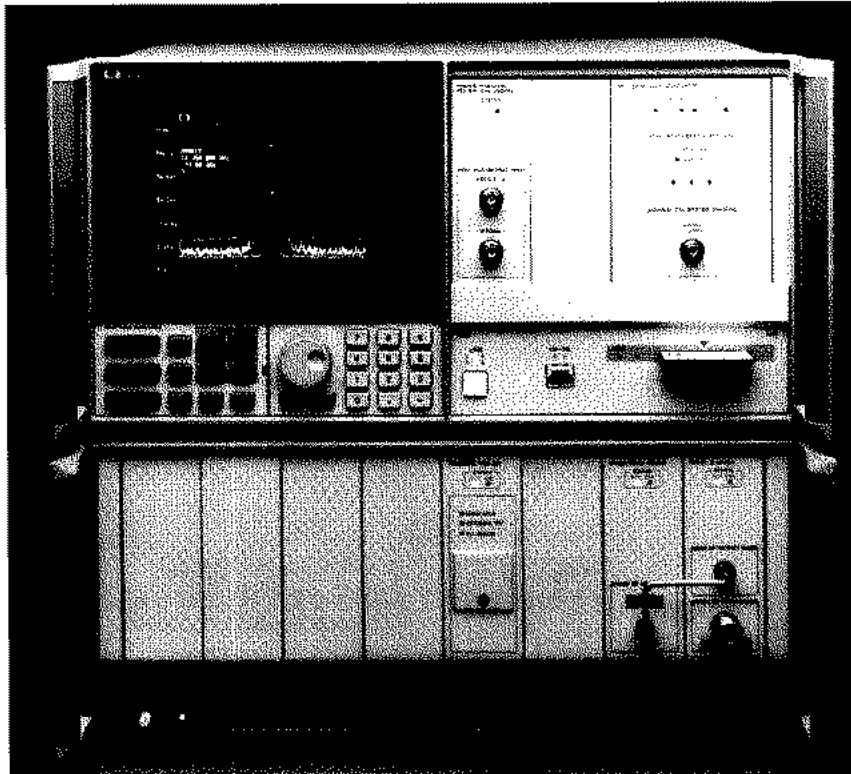

50 kHz to 22 GHz

Price and performance choices

The HP 71200C/P microwave spectrum analyzer offers a wide variety of price and performance options and a frequency range of 50 kHz to 22 GHz.

The standard configuration gives unpreselected microwave capability at just over the price of an RF analyzer with similar performance in terms of speed, phase noise, and feature set. If you make RF measurements but occasionally view microwave signals, this analyzer may be ideal. Or, if you measure known signals in a controlled environment such as manufacturing, this analyzer offers high performance at an economical cost.

For coverage to 325 GHz, you can add an HP 70907B external mixer interface module.

The HP 70620B preamplifier modules can be used with the HP 71200C/P spectrum analyzer for improved sensitivity. Option 001 on the HP 70620B provides coverage down to 100 kHz.

Use the HP 70700A digitizer for 80 ms sweep times in zero-span (fixed-tuned).

Refer to the HP 70000 Spectrum Analyzer Overview for more details.

Spectrum Analyzers

HP 70000 Series

HP 71200C/P

Specifications

Specifications describe the instrument's warranted performance over the 0° to +55° C temperature range. **Characteristics** provide information about non-warranted instrument performance. Nominal values indicate the expected value of the parameter. All specifications apply after the instrument's temperature has been stabilized after a one-hour warm-up, self-calibration routines have been run, and the preselector peak function has been executed. Where specifications are subject to minimization with error correction routines, corrected limits are given unless noted.

Frequency

Frequency range			
HP 70905A	50 kHz - 22 GHz Tunable in 1 Hz increments		
H = high IF (3.6214 GHz)	N	1st IF	Frequency
L = low IF (321.4 MHz)	1	H-	50 kHz-2.9 GHz
N = harmonic number	1	L-	2.7-6.2 GHz
	2	L-	6.0-12.7 GHz
	3	L+	12.0-19.9 GHz
	4	L+	19.7-22 GHz

Frequency readout accuracy

Span ≤ 10 MHz × N¹	± [(freq readout × freq ref acc) + 1.0% of span + 10 Hz]
Span > 10 MHz × N¹	
<input type="checkbox"/> Sweep ≥ 20 ms	± [(freq readout × freq ref acc) + 1.5% of span + 10 Hz]
<input type="checkbox"/> Sweep ≤ 10 ms	± [(freq readout × freq ref acc) + 2.5% of span + 10 Hz]

Frequency span

Range	0-22 GHz in 0.5% increments	
Accuracy		
<input type="checkbox"/> Span ≤ 10 MHz	± [1% of span + (span × freq ref acc)]	
<input type="checkbox"/> Span > 10 MHz		
Sweep ≥ 50ms	± [1.5% of span + (span × freq ref acc)]	
Sweep ≥ 20ms	± [2.5% of span + (span × freq ref acc)]	
Sweep ≥ 10ms	± [4.0% of span + (span × freq ref acc)]	

Frequency reference accuracy

	w/ HP 70310A	w/o HP 70310A
Aging	< 1x10 ⁻⁷ /year, < 5x10 ⁻¹⁰ /day (7-day avg.)	< 3x10 ⁻⁶ /year
Temperature drift	< 7x10 ⁻⁹	< 1x10 ⁻⁵

Spectral purity²

Frequency range	Noise sideband	Offset
<input type="checkbox"/> 50 kHz-2.9 GHz	< -108 dBc/Hz	10 kHz
<input type="checkbox"/> 2.7-6.2 GHz	< -108 dBc/Hz	30 kHz
<input type="checkbox"/> 6.0-12.7 GHz	< -102 dBc/Hz	30 kHz
<input type="checkbox"/> 12.5-19.9 GHz	< -98 dBc/Hz	30 kHz
<input type="checkbox"/> 19.7-22/26.5 GHz	< -96 dBc/Hz	30 kHz
Line and system related sidebands	< -65 dBc + 20 log N ¹	

Frequency

Residual FM	
Span > 10 MHz × N¹	< 25 kHz p-p in 0.1 s (measurement BW = 100 kHz)
Span ≤ 10 MHz × N¹	Determined from phase-noise sidebands
Frequency drift	For spans > 10 MHz × N ¹ , freq drift is ±1 kHz/s and ±150 kHz/° C. Errors due to drift are not cumulative sweep to sweep.
Sweep time	
Range (continuous)	10 ms to 1000 s
Accuracy	± 2%
Trigger	Free run, line, video, external
Resolution bandwidth (3 dB, synchronously tuned)	
Range	10 Hz-300 kHz (HP 70902A)
(1, 3, 10 sequence)	100 kHz - 3 MHz (HP 70903A) and 10% increments except 3 kHz-10 kHz
Accuracy	± 20%
Selectivity (-60 dB/-3 dB)	
Bandwidth	
<input type="checkbox"/> 10 Hz-3 kHz	< 12:1
<input type="checkbox"/> 10 kHz - 3 MHz	< 16:1
Video bandwidth	
Range	3 Hz-300 kHz (HP 70902A)
(1, 3, 10 sequence)	300 Hz-3 MHz (HP 70903A) When set to maximum (300 kHz or 3 MHz), effective bandwidth is greater than specified.
Accuracy	± 20% (characteristic)

¹ N = Harmonic mixing band constant.

² Refer to Figure 1 in the Spectrum Analyzer Overview section for typical phase noise.

Spectrum Analyzers

HP 70000 Series

HP 71200C/P

Amplitude		
Maximum safe input power		
AC average continuous	+15 dBm (0 dB attn)	
	+25 dBm (10 dB attn)	
	+30 dBm (> 10 dB attn)	
Pulse power	100 W, 10 ms pulse (\geq 40 dB attn)	
DC	0 V	
Display range (10 divisions)		
Calibration log	0.01 -20 dB/div in 0.5% increments	
Linear	0 to 10% of reference level per division	
Reference level range		
Log	+30 to -1400 dBm	
Linear	7.07 V to 22 nV	
Calibrator uncertainty	\pm 0.3 dB (-10 dBm, 300 MHz)	
Input attenuator switching repeatability	\pm 0.2 dB	
IF Gain Accuracy	<i>Gain</i>	<i>20° to 30° C</i> <i>0° to 50° C</i>
	10 dB	\pm 0.2 dB \pm 0.2 dB
	20 dB	\pm 0.2 dB \pm 0.2 dB
	30 dB	\pm 0.2 dB \pm 0.3 dB
	40 dB	\pm 0.2 dB \pm 0.5 dB
	50 dB	\pm 0.2 dB \pm 0.6 dB
Scale fidelity	<i>Bandwidth</i>	<i>Fidelity</i>
Log, corrected (1-3-10)		
HP 70902A	10 Hz	\pm 0.7 dB
(0 to 90 dB)	30 Hz to 100 kHz	\pm 0.5 dB
	300 kHz	\pm 0.7 dB
Log, uncorrected	All	\pm 3.0 dB
Incremental, corrected	All	\pm 0.1 dB/1dB
Linear	\pm 7.5% of reference level	
Amplitude temperature drift (nominal)	\pm 0.05 dB/°C	
-10 dBm ref level, 10 dB input attn, 100 Hz res BW (HP 70902A IF)	(Accumulated error is eliminated by running internal correction routine.)	
300 kHz res BW (HP 70903A IF)		
Resolution bandwidth switching repeatability		
in 1, 3, 10 sequence	\pm 0.2 dB	
All bandwidths	\pm 3 dB (uncorrected)	
Marker resolution	\pm 0.03 dB	

Amplitude			
Total amplitude range	-132 to +30 dBm		
Displayed average noise level²			
(0 dB attn)	<i>Band</i>	<i>DANL (dBm)</i>	
10 Hz Res BW	10 MHz-2.9 GHz	< -129	
	2.7 GHz-6.2 GHz	< -132	
	6.0 GHz-12.7 GHz	< -125	
	12.5 GHz-19.9 GHz	< -120	
	19.7 GHz-22 GHz	< -116	
100 kHz res BW	For freq >1 MHz, displayed average noise level is 40 dB higher than above.		
Gain compression level			
0 dB input	< 0.5 dB for signal levels \pm -10 dBm		
Spurious responses	<i>Input</i>	<i>Spurious</i>	
for mixer level \leq -40 dBm	50 kHz - 10 MHz	< -60 dBc	
All spurious responses, except as listed below, are less than these values (10-dB attn)	10 MHz - 22 GHz	< -70 dBc	
Second harmonic distortion	<i>Band</i>	<i>Second harmonic</i>	
for mixer level \leq -40 dBm	100 kHz-20 MHz	< -60 dBc	
(10-dB attn)	20 MHz-2.9 GHz	< -70 dBc	
	2.7-6.2 GHz	< -70 dBc	
	6.0-12.7 GHz	< -60 dBc	
	12.5-19.9 GHz	< -55 dBc	
	19.7-22 GHz	< -50 dBc	
Third-order intermodulation distortion	<i>Center frequency</i>	<i>Intermod products</i>	<i>Equiv TOI</i>
for two signals, each \leq -30 dBm at mixer (10 dB attn)	100 Hz-10 MHz	< -66 dBc	+3 dBm
	10 MHz-6.2 GHz	< -74 dBc	+7 dBm
	6.0-22 GHz	< -76 dBc	+8 dBm
Image responses for RF input < -85 dBc levels \leq 0 dBm offset at 6, 42.8, and 642.8 MHz (10 dB attn)			
Residual responses	<i>Range</i>	<i>Responses</i>	
(0 dB attn with input terminated)	10 MHz-6.2 GHz	< -100 dBm	
	6.0-12.7 GHz	< -92 dBm	
	12.5-19.9 GHz	< -88 dBm	
	19.7-22 GHz	< -83 dBm	
Frequency response	<i>Band</i>	<i>Variation</i>	
Peak variation	50 kHz-2.9 GHz	\pm 2.7dB	
	400 kHz-2.9 GHz	\pm 1.4 dB	
	2.7-6.2 GHz	\pm 1.4 dB	
	6.0-12.7 GHz	\pm 1.9 dB	
	12.5-19.9 GHz	\pm 2.5 dB	
	19.7-22 GHz	\pm 2.5 dB	
Referenced to 300 MHz, -10 dBm (10 dB attn)	50 kHz-2.9 GHz	+1.6-3.9 dB	
	400 kHz-6.2 GHz	\pm 2.3 dB	
	400 kHz-12.7 GHz	\pm 3.0 dB	
	400 kHz-19.9 GHz	\pm 3.8 dB	
	400 kHz-22 GHz	\pm 3.8 dB	

Spectrum Analyzers

HP 70000 Series

HP 71200C/P

Input/output characteristics

Front panel only. See individual module characteristics for complete information.

HP 70900B LO section		300 MHz calibrator	
Output	BNC (f), 50 Ω (nominal)		
Output power	-10 dBm \pm 0.3 dB		
Frequency accuracy	300 MHz x freq ref accuracy		
HP 70905A RF section (50 kHz to 22 GHz)			
RF input	HP 70905A Type-N (f); 50 Ω (nominal)		
LO emissions	< -10 dBm with 10 dB attn (nominal)		
VSWR (\leq 10 dB attn)	Freq (GHz)	VSWR (nominal)	
	0-12.7	< 1.7:1	
	12.5-18.0	< 2.0:1	
	18.0-22	< 2.5:1	
HP 70902A IF section			
Auxiliary video output	BNC (f), 0-1 V, 1 k Ω (nominal)		
3 MHz IF output (linear)	BNC (f), 50 Ω , 1.5:1 VSWR (nominal)		
Output power	-15 dBm nominal with -5 dBm RF input, 0 dB attn, and -10 dBm ref level		
HP-IB Codes	SH1 AH1 T6 L4 SR1 RL1 DC1 PP0 DT1 E2 C1		

General specifications

HP 71200C system components	HP 71200P system components
<input type="checkbox"/> HP 70001A	<input type="checkbox"/> HP 70310A
<input type="checkbox"/> HP 70004A	<input type="checkbox"/> HP 70902A
<input type="checkbox"/> HP 70900B	<input type="checkbox"/> HP 70905A
<input type="checkbox"/> HP 70001A	<input type="checkbox"/> HP 70310A
<input type="checkbox"/> HP 70004A	<input type="checkbox"/> HP 70207B E05
<input type="checkbox"/> HP 70900B	<input type="checkbox"/> HP 70902A
<input type="checkbox"/> HP 70905A	<input type="checkbox"/> HP 70905A
Environments/temperature	Operational, 0 to +55 $^{\circ}$ C storage, -40 to +75 $^{\circ}$ C
Humidity	Operational, 0 to 95% relative humidity at 45 $^{\circ}$ C
EMC	Conducted and radiated interference is in compliance with CISPR pub 11, FTZ 526/1979, and MIL-STD 461B, RE02/part 7
Vibration and shock	In compliance with MIL-T-28800E Type III Class 3
Power requirements	See requirements for HP 70001A and HP 70004A. All power requirements supplied by the mainframe (HP 70001A or 70004A).
Weight (nominal)	HP 71200C/P standard: 47.7 kg (105.6 lb)
Dimensions	
HP 70001A mainframe	177.0 mm (6.97") high, 425.4 mm (16.75") wide, 526.0 mm (20.7") long
HP 70004A display	222.0 mm (8.74") high, 425.4 mm (16.75") wide, 526.0 mm (20.7") long
Warranty	1 year (extendible with options)
Calibration cycle	3 years recommended

Features and compatibility

HP 70004A display features used: Memory card, direct-to-disk, keyboard (for title mode and writing small DLPs), direct plot (buffered), direct print, full color display

Mass storage

Memory card:	32 KB or 128 KB RAM per card
External:	SS80-compatible hard or flexible disk
User memory:	128 KB minimum, 32 KB minimum with firmware before 901008, about 2.5 KB to store an 800 point trace with its state. System memory is reduced when slave modules are added. Optional 1MB memory.

Compatible accessory modules

(slave modules to the HP 70900B master module)

<input type="checkbox"/> HP 70903A IF section	<input type="checkbox"/> HP 70907B external mixer interface module
<input type="checkbox"/> HP 70621A/HP 70620B preamplifiers	<input type="checkbox"/> HP 70700A digitizer
<input type="checkbox"/> HP 70300A/HP 70301A tracking generators	<input type="checkbox"/> HP 70205A monochrome display
<input type="checkbox"/> HP 70810B lightwave section	

Software available

<input type="checkbox"/> HP 11990A performance verification software
<input type="checkbox"/> HP 70871A scalar measurement personality

Spectrum Analyzers

HP 70000 Series

HP 71200C/P

Ordering Information

(NOTE: When adding or exchanging modules, be sure the final count will fit into the 8-slot HP 70001A mainframe and the 4-slot HP 70004A display/mainframe.)

HP 71200C/P spectrum analyzer

- Option 006** delete HP 70902A 10 Hz - 300 kHz IF section (*NOTE: HP 70903A 100 kHz-3 MHz IF section must be ordered*)
- Option 1BN** certificate of calibration
- Option 1BP** certificate of calibration and data
- Option 110** delete HP 70310A precision frequency reference
- Option 121** add distribution amplifier on the HP 70310A precision frequency reference (HP 70310A/001)
- Option 122** provide external reference capability and delete ovenized reference in the HP 70310A
- Option 200** delete display (operation and control over HP-IB only)
- Option 201** delete mainframe (*NOTE: count modules to ensure fit in mainframe*)
- Option 205** substitute HP 70205A display for HP 70004A display/mainframe
- Option 400** add 400 Hz power line frequency operation to the HP 70001A mainframe; add isolation transformer at 2.3 kg (5 lb) (HP 71200C only)
- Option 512** additional memory, 1 MB total, 90 KB user memory
- Option 810** rack mount slide kit for both the HP 70001A mainframe and the HP 70004A display/mainframe
- Option 908** rack flange kit to mount HP 70001A/HP 70004A without handles
- Option 910** extra user manual set containing (a) installation/ verification, (b) operation, and (c) program language reference
- Option 913** rack flange kit to mount HP 70001A/HP 70004A with handles attached
- Option 915** service manual set and software for troubleshooting and repair

Spectrum Analyzers

Microwave Spectrum Analyzer

HP 71209A/P

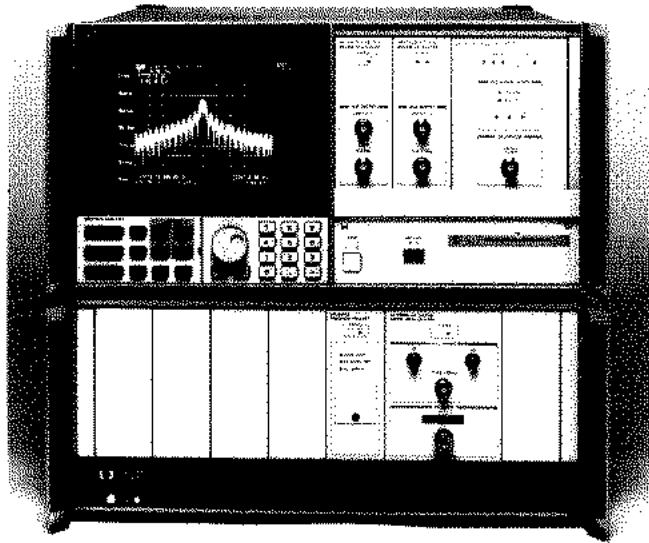

HP 71209A (above)

100 Hz to 26.5 GHz

-138 dBm to -128 dBm sensitivity across the frequency range

Compatible with HP 8566B spectrum analyzer programming codes

Built-in external mixer interface for millimeter applications

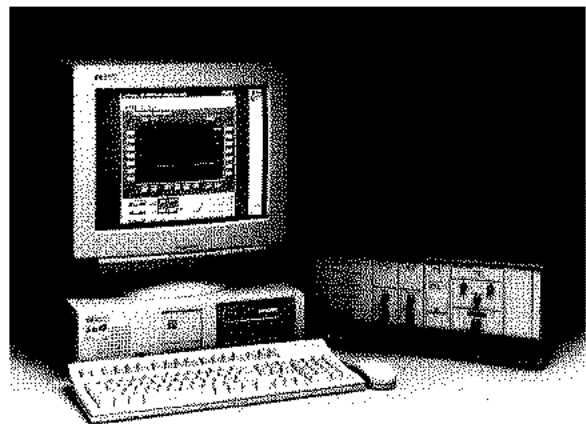

HP 71209P (right)

With full band sweeps from 100 Hz to 26.5 GHz and built-in external millimeter mixer capability, the HP 71209A/P spectrum analyzer meets the demanding needs of R&D, manufacturing, and automatic test equipment (ATE) applications. The analyzer's superb frequency accuracy, amplitude accuracy, and repeatability let you perform even the most demanding satellite tests. Option 001, a wide bandwidth downconversion path, simplifies surveillance applications.

The HP 71209A/P can help cut your software development time. The spectrum analyzer is compatible with HP 8566B¹ programming code, so you can leverage existing software. And your initial instrument investment is protected, even as you upgrade your system or move into different projects.

¹ See Product Note 70900-1 for detailed compatibility information.

The flexible HP 71209A/P lets you reconfigure hardware, vary performance, and upgrade or downsize your test system—all without requiring major software changes.

A compact system such as the HP 71209A/P (a minimal system without a display fits into five slots of a mainframe) is perfect for mobile testers, ATE, or manufacturing test stations. And numerous accessories

enable you to enhance the performance and expand the capabilities of the system at any time.

The HP 71209A/P, part of the HP 70000 series of spectrum analyzers with proven reliability and repeatability, has a three-year recommended calibration cycle—and gives you a test instrument with a very low lifetime cost.

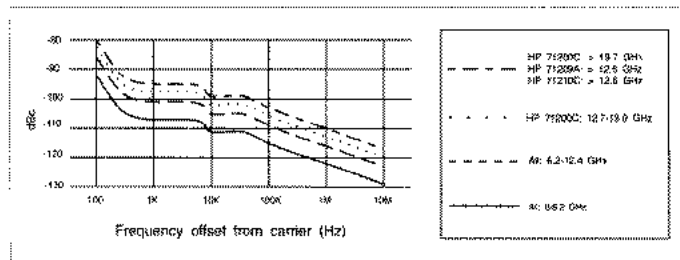

Figure 1. Typical local oscillator phase noise sidebands at offsets from 100 Hz to 10 MHz and frequencies to 6.2 GHz.

Spectrum Analyzers

Microwave Spectrum Analyzer

HP 71209A/P

Specifications

Specifications describe the instrument's warranted performance over the 0° to +55°C temperature range. **Characteristics** provide information about non-warranted instrument performance. Nominal values indicate the expected value of the parameter. All specifications apply after the instrument's temperature has been stabilized after a one-hour warm-up, self-calibration routines have been run, and the preselector peak function has been executed. Where specifications are subject to minimization with error correction routines, corrected limits are given unless noted.

Frequency	
Frequency range	100 Hz–26.5 GHz Tunable in 1 Hz increments
Frequency readout accuracy	
Span ≤ 10 MHz x N ¹	± [(freq readout x freq ref acc) + 1.0% of span + 10 Hz]
Span > 10 MHz x N ¹	
□ Sweep ≥ 20 ms	± [(freq readout x freq ref acc) + 1.5% of span + 10 Hz]
□ 10 ms ≤ Sweep ≤ 20 ms	± [(freq readout x freq ref acc) + 2.5% of span + 10 Hz]
Frequency span	
Range	0–26.5 GHz in 0.5% increments
Accuracy	
□ Span ≤ 10 MHz x N ¹	± [1% of span + (span x freq ref acc)]
□ Span > 10 MHz x N ¹	
Sweep ≥ 50 ms	± [1.5% of span + (span x freq ref acc)]
Sweep ≥ 20 ms	± [2.5% of span + (span x freq ref acc)]
Sweep ≥ 10 ms	± [4.0% of span + (span x freq ref acc)]
Frequency reference accuracy	
Aging	w/ HP 70310A w/o HP 70310A < 1 x 10 ⁻⁷ /year, < 3 x 10 ⁻⁶ /year < 5 x 10 ⁻¹⁰ /day (7-day avg.)
Temperature drift	< 7 x 10 ⁻⁹ < 1x10 ⁻⁵
Spectral purity²	
Noise sideband	<i>Noise sideband (dBc/Hz) (characteristic)</i>
	Offset N=1 N=2 N=4
	100 Hz -85 -79 -73
	300 Hz -85 -82 -76
	1 kHz -94 -88 -82
	3 kHz -104 -98 -92
	10 kHz (spec) < 108 < 102 < -96
	30 kHz -111 -115 -99
	100 kHz -115 -109 -103
	300 kHz -123 -117 -111
	1 MHz -135 -129 -123
	3 MHz -145 -139 -133
	10 MHz -153 -147 -141
Line and system related sidebands	< -65 dBc +20 Log N ¹

Frequency drift	For spans > 10 MHz x N1, freq. drift is ± 1 kHz/s and ± 150 kHz/° C. Errors due to drift are not cumulative from sweep to sweep.
Sweep time	
Range (continuous)	10 ms to 1,000 s
Accuracy	± 2%
With HP 70700A	Swept freq spans: 15 ms to 355 s Fixed freq (zero span): 80 ms to 355 s with 800 point trace
Trigger	Free run, line, video, external
Resolution bandwidth (3 dB, synchronously tuned)	
Range	10 Hz–300 kHz (HP 70902A) 100 kHz–3 MHz (HP 70903A) (1, 3, 10 sequence and 10% increments except 3 kHz–10 kHz)
Accuracy	± 20%
Selectivity (-60 dB/-3 dB)	
Bandwidth	
□ 10 Hz–3 kHz	< 12:1
□ 10 kHz–3 MHz	< 16:1
Video bandwidth	
Range (1, 3, 10 sequence)	3 Hz–300 kHz (HP 70902A) 300 Hz–3 MHz (HP 70903A)
Accuracy	±20% (characteristic) When set to maximum (300 kHz or 3 MHz), bandwidth is > 300 kHz (HP 70902A) or > 4.5 MHz (HP 70903A).

¹ N is the harmonic mixing number, N = 1 from 100 Hz–6.2 GHz; N = 2 from 6.0 GHz–12.8 GHz; N = 4 from 12.6–26.5 GHz.

² Refer to figure 1 for typical phase noise.

Spectrum Analyzers

Microwave Spectrum Analyzer

HP 71209A/P

Amplitude			
Total amplitude range	-138 to +30 dBm		
Maximum safe input power			
AC (average continuous)	+30 dBm (≥ 10 dB attn)		
Pulse power	100 watts, 10 ms pulse (≥ 50 dB attn)		
Mixer	≤ 15 dBm continuous power		
DC	0 V		
Displayed average noise level			
	<i>Frequency</i>	<i>DANL</i>	
10 Hz res BW, 0 dB	100 Hz	< -92 dBm (char)	
attn. 3 Hz video BW	300 Hz	< -95 dBm (char)	
Ref level ≤ -75 dBm	1 kHz	< -101 dBm (char)	
	3 kHz	< -111 dBm (char)	
	10 kHz	< -118 dBm (char)	
	30 kHz	< -118 dBm (char)	
	100 kHz	< -122 dBm (char)	
	300 kHz	< -130 dBm (char)	
	1 MHz	< -139 dBm (char)	
	3 MHz	< -139 dBm (char)	
	10 MHz-2.0 GHz	-138 dBm	
	2.0-12.8 GHz	-137 dBm	
	12.8-22.0 GHz	-130 dBm	
	22.0-26.5 GHz	-128 dBm	
with HP 70620B	1.0-12.8 GHz	-154 dBm	
	12.6-22 GHz	-148 dBm	
	22.0-26.5 GHz	-145 dBm	
Gain compression level (10 dB input attn)			
< 0.5 dB for signal levels ≤ 0 dBm			
Spurious responses			
	<i>Input</i>	<i>Response</i>	
	100 Hz-10 MHz	< -60 dBc	
	10 MHz-22 GHz	< -70 dBc	
	(Preselector ON for HP 70910A)		
Second harmonic distortion			
	<i>Frequency</i>	<i>Response</i>	
	100 Hz-20 MHz	< -60 dBc	
	20 MHz-2.9 GHz	< -75 dBc	
	2.9-26.5 GHz	< -100 dBc	
	26.5 GHz-40.0 GHz	< -70 dBc	
	(Preselector ON for HP 70910A)		
Third-order intermodulation (20-30°C)			
HP 70902A IF section ^{3,4}	<i>Center frequency</i>	<i>Intermod. products</i>	<i>Equiv. TOI</i>
	100 Hz-20 MHz	< -64 dBc	+2 dBm
	20 MHz-2.9 GHz	< -78 dBc	+9 dBm
	2.7-6.2 GHz	< -68 dBc	+4 dBm
	6.0-26.5 GHz	< -64 dBc	+2 dBm
HP 70903 IF section ^{4,5}	100 Hz-20 MHz	< -54 dBc	+2 dBm
	20 MHz-2.9 GHz	< -68 dBc	+9 dBm
	2.7-6.2 GHz	< -58 dBc	+4 dBm
	6.0-26.5 GHz	< -54 dBc	+2 dBm

Amplitude cont.			
Image responses (for RF input levels ≤ 0 dBm, 10 dB attn)			
6 MHz and 42.8 MHz	< -85 dBc		
642.8 MHz	<i>Center frequency</i>	<i>Rejection</i>	
	100 kHz-2.9 GHz	-85 dBc	
	2.7-6.2 GHz	-70 dBc	
	6.0-12.8 GHz	-70 dBc	
	12.7-18.0 GHz	-70 dBc	
18.0-26.5 GHz	-60 dBc		
Residual responses			
<i>Range</i>	<i>Responses</i>		
(0 dB attn, input terminated)	10 MHz-26.5 GHz	< -100 dBm	
Multiple and out-of-band responses			
For inputs ≤ 26.5 GHz and RF levels ≤ 0 dBm, ≥ 10 dB attn	< -70 dBc (Preselector ON with HP 70910A)		
Display range (10 divisions)			
Log	0.01-20 dB/div in 0.5% increments		
Linear	10% of reference level per division		
Reference level range			
Log	+30 to -140 dBm		
Linear	7.07 V to 22 nV (50 W system)		
Frequency response			
	<i>0°-55° C</i>	<i>20°-30° C</i>	<i>0°-55° C</i>
<i>Frequency range variation</i>	<i>Peak calibrator⁵</i>	<i>Ref. to calibrator⁵</i>	<i>Ref. to calibrator⁵</i>
100 Hz-2.9 GHz	± 1.5 dB	± 2.0 dB	± 2.0 dB
2.7-6.2 GHz	± 2.0 dB	± 2.0 dB	± 3.0 dB
6.0-12.8 GHz	± 2.0 dB	± 2.0 dB	± 3.0 dB
12.6-22.0 GHz	± 2.0 dB	± 2.0 dB	± 3.5 dB
22.0-26.5 GHz	± 2.5 dB	± 2.5 dB	± 4.0 dB
Frequency response (10 dB attn, 20-30°C, preset preselector DAC)			<i>Ref. to calibrator⁶</i>
2.7-22.0 GHz			+2.0, -3.0 dB
22.0-26.5 GHz (for spans ≤ 100 MHz)			+2.5, -3.5 dB
Calibrator uncertainty			
± 0.3 dB (-10 dBm, 300 MHz)			
Input attenuator			
Range	0-65 dB range in 5 dB steps		
Switching repeatability	± 0.2 dB		
Accuracy	<i>Center frequency</i>	<i>Referenced to the 10 dB setting</i>	
	0.0-2.9 GHz	± 1.2 dB	
	2.9-12.7 GHz	± 2.3 dB	
	12.7-19.9 GHz	± 2.8 dB	
	19.9-26.5 GHz	± 4.8 dB	
Preselector bypass switch repeatability $< \pm 0.2$ dB (HP 70910A only)			

Spectrum Analyzers

Microwave Spectrum Analyzer

HP 71209A/P

Amplitude cont.

IF gain accuracy	Gain	20° to 30° C	0° to 50° C
HP 70902A	10 dB±	± 0.2 dB	± 0.2 dB
	20 dB	± 0.2 dB	± 0.2 dB
	30 dB	± 0.2 dB	± 0.3 dB
	40 dB	± 0.2 dB	± 0.5 dB
	50 dB	± 0.2 dB	± 0.6 dB
	60 dB	± 0.4 dB	± 0.8 dB
HP 70903A	10 dB	± 0.1 dB	
	20 dB	± 0.3 dB	

Scale fidelity	Bandwidth	Fidelity
Log, corrected (1-3-10)		
<input type="checkbox"/> HP 70902A	10 Hz	± 0.7 dB
	(0 to 90 dB)	± 0.5 dB
<input type="checkbox"/> HP 70903A	300 kHz-1 MHz	± 0.5 dB
	(0 to 75 dB)	± 0.7 dB
Log, uncorrected	All	± 3.0 dB
Incremental, corrected	All	± 0.1 dB/1dB
Linear	± 7.5% of reference level	

Amplitude temperature drift ± 0.05 dB/°C at 300 MHz and 100 Hz Res BW (nominal)
(HP 70902A IF); 300 kHz Res BW (HP 70903A IF)
-10 dBm ref. level, 10 dB input attn. Accumulated error is eliminated by running internal correction routine.

Resolution bandwidth switching repeatability ± 0.2 dB in 1, 3, 10 sequence
± 3 dB (uncorrected)

Marker resolution ± 0.03 dB

³ For two signals, each ≤ 0 dBm at RF input with 10 dB attenuation.

⁴ For two signals, each ≤ -10 dBm at RF input with 10 dB attenuation.

⁵ TDI is degraded by 2 dB over 0°-55° C temperature range.

⁶ Referenced to 300 MHz, -10 dBm calibrator. Does not include the calibrator amplitude error.

Input/output characteristics

Front panel only, or as given below. See module characteristics for more detailed information.

HP 709006 LO Section

300 MHz calibrator

Output	BNC (f), 50 Ω (nominal)
<input type="checkbox"/> Output power	-10 dBm ± 0.3 dB
<input type="checkbox"/> Frequency accuracy	300 MHz x frequency reference accuracy

HP 70909A and 70910A RF sections (100 Hz to 26.5 GHz)

RF Input	APC 3.5; 50 W (nominal)		
	LO emissions (10 dB attn)	Center frequency	Total signal power
		Preselector ON	Preselector OFF (HP 70910A)
	0-2.9 GHz	<-100 dBm	<-80 dBm
	2.9-26.5 GHz	<-100 dBm	<-50 dBm
VSWR (≥ 10 dB attn)	Frequency	VSWR (nominal)	
	0-6.2 GHz	< 1.4:1	
	6.0-26.5 GHz	< 2.0:1	

Input/output characteristics cont.

321.4 MHz external IF input SMA (f), 50 Ω (nominal)		
Return loss	14 dB from 271.4-371.4 MHz	
Maximum safe input level (spec)	ac: 0 dBm	dc: ± 3 V
Noise figure	< 7.0 dB	
SHI	> (+ 30 - CL) dBm	
TOI	> (+ 10 - CL) dBm	
	(CL = external mixer conversion loss)	
Tune and span output		
	BNC (f), >10 kΩ load impedance	
Voltage range	0 to + 13.25 V	
Tuning sensitivity	RF input selected, 0.5 V/GHz RF freq EM input selected, 1.5 V/GHz LO freq	
Preselector DAC		
	(8 bit DAC)	
Voltage range	RF input selected	N=1: +13.3 mV N=2: +26.7 mV N=4: +53.3 mV
	EM input selected	+40.0 mV
First LO Output	SMB (f), 50 Ω, VSWR < 2.1:1	
Freq range	3.0-6.6 GHz (spec)	
Output power (spec)	0°-55° C	
<input type="checkbox"/> Minimum	14.0 dBm	
<input type="checkbox"/> Maximum	17.5 dBm	
321.4 MHz IF output		
	Rear panel SMB (m), 50 Ω (nominal)	
Bandwidth	-3 dB Bandwidth	
	RF frequency	HP 70909A HP 70910A (spec)
	0-2.9 GHz	> 48 MHz > 48 MHz
	2.7-26.5 GHz (preselector ON)	> 27 MHz > 36 MHz
	2.7-26.5 GHz (preselector OFF)	N/A > 200 MHz
	EM input	> 200 MHz > 200 MHz
Level	-5 dBm for 0 dBm RF input and 10 dB atten	
Return loss	14 dB at 321.4 ± 50 MHz	
HP 70902A IF section		
Auxiliary video output	BNC (f), 0-1 V, 1 k Ω (nominal)	
3 MHz IF output (linear)	BNC (f), 50 Ω, < 1.5:1 VSWR (nominal)	
Output power	-15 dBm nominal with -5 dBm RF input, 0 dB atten, -10 dBm reference level	
HP 70903A IF section		
Auxiliary video output	BNC (f), 0-1 V, 100 Ω (nominal)	
21.4 MHz IF output	BNC, 50 Ω, < 1.5:1 VSWR (char)	
Output power	-15 dBm nominal with -5 dBm at RF input, 0 dB atten, -10 dBm reference level	
HP-IB Codes	SH1 AH1 T6 L4 SR1 RL1 DC1 PP0 DT1 E2 C1	

Spectrum Analyzers

Microwave Spectrum Analyzer

HP 71209A/P

Typical performance summary with HP 11970 and 11974 series external mixers

Model number	Frequency range (GHz)	LO harmonic number	Sensitivity (10 Hz res BW)	Frequency response (uncorrected)		Typical gain compression
				0°–55° C	20°–30° C	
HP 11974A	26.5–40	8	< -111 dBm	± 4.5		+5
HP 119740	33–50	10	< -106 dBm	± 4.0		0
HP 11974U	40–60	10	< -109 dBm	± 4.0		0
HP 11974V	50–75	14	< -94 dBm	± 4.0		+3
HP 11970K	18–26.5	6	< -128 dBm	± 3.2	± 2.3	< -3
HP 11970A	26.5–40	8	< -126 dBm	± 3.2	± 2.3	< -5
HP 11970Q	33–50	10	< -124 dBm	± 3.2	± 2.3	< -7
HP 11970U	40–60	10	< -124 dBm	± 3.2	± 2.3	< -7
HP 11970V	50–75	14	< -112 dBm	± 3.2	± 2.3	< -3
HP 11970W	5–110	18	< -106 dBm	± 4.5	± 3.5	< -1

General specifications

HP 71209A system components

- HP 70001A mainframe
- HP 70004A display
- HP 70900B local oscillator
- HP 70310A precision frequency reference
- HP 70902A IF section
- HP 70903A IF section
- HP 70909A RF section

HP 71209P system components

- HP 70001A mainframe
- HP 70207B E05 display
- HP 70900B local oscillator
- HP 70310A precision frequency reference
- HP 70902A IF section
- HP 70903A IF section
- HP 70909A RF section

Opt. 001 replaces the HP 70909A with the HP 70910A wide bandwidth RF section.

(NOTE: When adding or exchanging the modules, be sure the final count will fit into the 8-slot HP 70001A mainframe and the 4-slot HP 70004A display/mainframe.)

Environmental temperature: Operational, 0° to +55° C; storage, -40° to +75° C

Humidity: Operational, 0 to 95% relative humidity at 45° C

EMC: Conducted and radiated interference is in compliance with CISPR pub 11, FTZ 526/1979, and MIL-STD 461B, RE02/part 7.

Vibration and shock: In compliance with MIL-T-28800E Type III Class 3

Power requirements (characteristic)

HP 71209A/P	329 W
HP 70900B	50 W
HP 70902A	19 W
HP 70903A	16 W
HP 70909A	40 W
HP 70910A	40 W
HP 70310A	25 W
HP 70001A	42 W ⁷
HP 70004A	137 W ⁷

Weight (nominal) HP 71209A/P standard: 51.6 kg (115.8 lb)

Dimensions:

- HP 70001A mainframe: 177.0 mm (6.97") high, 425.4 mm (16.75") wide, 526.0 mm (20.7") long
- HP 70004A display: 222.0 mm (8.74") high, 425.4 mm (16.75") wide, 526.0 mm (20.7") long

Warranty: 1 year (extendible with Option W 30)

Calibration cycle: 3 years recommended

Features and compatibility

HP 70004A system features used: memory card reader, direct-to-disk data storage, keyboard (for title mode and writing short DLPS), direct plot (buffered), direct print, color display

Mass storage/memory card: 32 or 128 KB of RAM per card

External: SS80-compatible hard or flexible disk

User memory: 128 KB minimum (32 KB minimum with firmware before 901008), about 2.5 KB to store an 800 point trace with its state. System memory is reduced when slave modules are added. Optional 1 Mbyte memory is available with Option 512.

Compatible accessory modules

- Tracking generators**
 - HP 70300A; 20 Hz–2.9 GHz
 - HP 70301A; 2.7–18.0 GHz
- Tracking sources**
 - HP 85644A; 300 kHz–6.2 GHz
 - HP 85645A; 300 kHz–26.5 GHz
- Preamplifiers**
 - HP 70621A; 100 kHz–2.9 GHz (100 kHz–26.5 GHz with Option 001)
- Digitizer**
 - HP 70700A; 20 Msa/s, 256 K RAM

Software available from HP

- HP 11990A performance verification software
- HP 70871A scalar measurement personality

Additional Information

Product Note

HP 70000 Series Spectrum Analyzer

Programming Code Compatibility to the HP 8566B (70900-1)
part no. 5091-2583E

⁷ Accounts for power supply efficiency in standard module configuration.

Spectrum Analyzers

Microwave Spectrum Analyzer

HP 71209A/P

Ordering Information

HP 71209A spectrum analyzer

- Option 001** wide bandwidth RF section, replaces the HP 70909A with the HP 70910A wide bandwidth RF section
- Option 1BN** certificate of calibration
- Option 1BP** certificate of calibration and data
- Option 006** delete HP 70902A 10 Hz–300 kHz IF section (*NOTE: Requires an HP 70903A 100 kHz - 3 MHz IF section*)
- Option 007** delete HP 70903A 100 kHz–3 MHz IF section (*NOTE: Requires an HP 70902A 10 Hz–300 kHz IF section*)
- Option 110** delete HP 70310A precision frequency reference
- Option 121** add distribution amplifier on the HP 70310A precision frequency reference (HP 70310A/001)
- Option 122** provide external reference capability and delete ovenized reference in the HP 70310A
- Option 200** delete display (operation and control over HP-IB only)
- Option 205** substitute HP 70205A display for HP 70004A display/mainframe
- Option 400** add 400 Hz power line frequency operation to the HP 70001A mainframe; adds isolation transformer at 2.3 kg (5 lb)
- Option 512** additional memory, 1 Mbyte total, 700 Kbyte user memory
- Option 660** add HP 8566B programming manual
- Option 810** rack mount slide kit for both the HP 70001A mainframe and the HP 70004A display/mainframe
- Option 908** rack flange kit to mount HP 70001A/HP 70004A without handles
- Option 910** extra user manual set containing (a) installation/verification, (b) operation, and (c) program language reference
- Option 913** rack flange kit to mount HP 70001A/HP 70004A with handles attached
- Option 915** service manual set and software for troubleshooting and repair
- Option W30** 3-year customer return repair

HP 71209P spectrum analyzer

- Option 001** wide bandwidth RF section, replaces the HP 70909A with the HP 70910A wide bandwidth RF section
- Option 1BN** certificate of calibration
- Option 1BP** certificate of calibration and data
- Option 006** delete HP 70902A 10 Hz–300 kHz IF section (*NOTE: Requires an HP 70903A 100 kHz - 3 MHz IF section*)
- Option 007** delete HP 70903A 100 kHz–3 MHz IF section (*NOTE: Requires an HP 70902A 10 Hz–300 kHz IF section*)
- Option 010** Add HP 70001A mainframe
- Option 016** Add HP 70620B Option 001 preamplifier
- Option 017** Add HP 70620B preamplifier
- Option 110** delete HP 70310A precision frequency reference
- Option 121** add distribution amplifier on the HP 70310A precision frequency reference (HP 70310A/001)
- Option 122** provide external reference capability and delete ovenized reference in the HP 70310A
- Option 660** add HP 8566B programming manual
- Option 810** rack mount slide kit for both the HP 70001A mainframe and the HP 70004A display/mainframe
- Option 908** rack flange kit to mount HP 70001A/HP 70004A without handles
- Option 910** extra user manual set containing (a) installation/ verification, (b) operation, and (c) program language reference
- Option 913** rack flange kit to mount HP 70001A/HP 70004A with handles attached
- Option 915** service manual set and software for troubleshooting and repair
- Option AX4** rack flange kit
- Option AXE** rack flange kit with handles
- Option W30** 3-year customer return repair

Spectrum Analyzers

Microwave Spectrum Analyzer

HP 71209A/P Option Z40

Continuous sweeps from 100 Hz to 40 GHz with all-electronic sweeping

Ruggedized 2.4 mm input connector

RF preselection from 2.7 to 40 GHz

Sensitivity of -122 dBm at 26.5 GHz and -107 dBm at 40 GHz

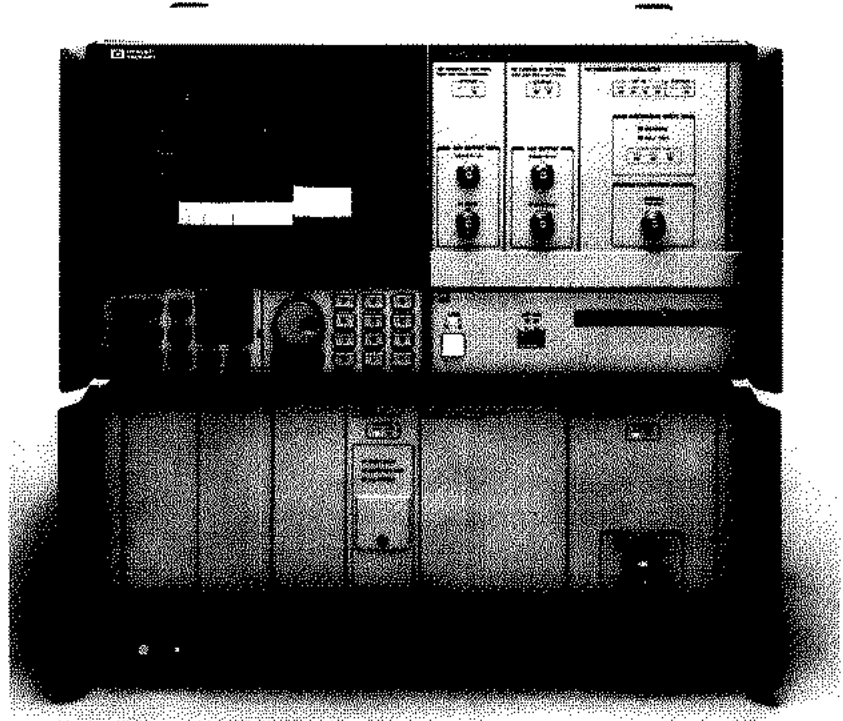

HP 71209A Option Z40

Option Z40 adds a 26.5 to 40 GHz preselected RF section to the HP 71209A/P spectrum analyzer. This enables the analyzer to sweep from 100 Hz to 40 GHz using a single 2.4 mm connector, with all-electronic switching between bands.

Now, communication and lightwave systems approaching 40 GHz can be characterized with a single unit. External mixers are not required.

Advanced HP components are used to control the performance of critical circuitry in the HP 71209 Option Z40. These components include broadband GaAs MMICs, YIG tuned filters, and BaFe tuned filters (an HP exclusive).

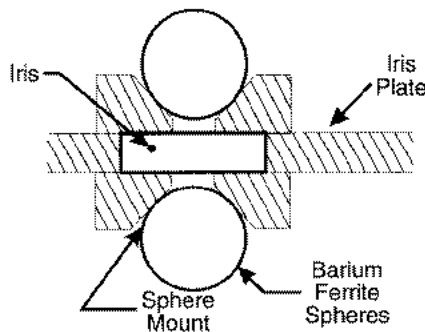

One of two barium-ferrite resonator sphere pairs used in the 26.5 to 40 GHz preselector in the HP 71209A/P Option Z40. The 0.2 mm (0.008 in.) diameter spheres are cemented onto the 0.4 mm (0.016 in.) diameter sphere mounts for precise placement on the preselector assembly.

Spectrum Analyzers

Microwave Spectrum Analyzer

HP 71209A/P Option Z40

Specifications

(changes from standard HP 71209A/P)

Frequency

Frequency range	100 Hz to 40.0 GHz, tunable in 1 Hz increments		
	<i>Band1</i>	<i>Signal frequency in GHz</i>	<i>First LO frequency in GHz</i>
	1H-	0 to 2.9	3.6214 to 6.5214
	1L-	2.7 to 6.2	3.0214 to 6.5214
	2L-	6.0 to 12.8	3.1607 to 6.5607
	4L+	12.6 to 26.5	3.0697 to 6.5447
	8L+	26.3 to 40.0	3.247 to 4.960

NOTE: H- High IF (3.6214 GHz IF), L- Low IF (321.4 MHz IF), and numeral = mixing harmonic number.

Frequency Span

Range 0 to 40.0 GHz in 0.5% increments

Spectral Purity²

Noise Sidebands Single sideband noise (dBc/Hz)

<i>Offset</i>	<i>Band</i>				
	<i>1H</i>	<i>1L</i>	<i>2L</i>	<i>4L+</i>	<i>8L+</i>
□ 100 Hz (characteristic)	-85	-85	-79	-73	-67
□ 300 Hz (characteristic)	-88	-88	-82	-76	-70
□ 1 kHz (characteristic)	-94	-94	-88	-82	-79
□ 3 kHz (characteristic)	-104	-104	-98	-92	-89
□ 10 kHz	<-108	<-108	<-102	<-96	<-90
□ 30 kHz (characteristic)	-111	-111	-105	-99	-93
□ 100 kHz (characteristic)	-115	-115	-109	-103	-97
□ 300 kHz (characteristic)	-123	-123	-117	-111	-105
□ 1 MHz (characteristic)	-135	-135	-129	-123	-117
□ 3 MHz (characteristic)	-145	-145	-139	-133	-127
□ 10 MHz (characteristic)	-153	-153	-147	-141	-135

Power line and display related sidebands

Offset *Maximum sideband level (dBc/Hz)*

N x 50, 60, 400 Hz	< -65 dBc + 20 log N ¹
24 kHz	< -65 dBc + 20 log N ¹
40 kHz	< -65 dBc + 20 log N ¹
80 kHz	< -65 dBc + 20 log N ¹

Synthesis related

Maximum level (dBc)
-65 dBc + 20 log N

Amplitude

Frequency response (preselector peaked)

Frequency range	<i>0°-55° C²</i>	<i>20°-30° C^{2,3}</i>	<i>0°-55° C^{2,3}</i>
22.0-40.0 GHz	±4.0 dB	±4.0 dB	±5.5 dB

Frequency response (preset preselector DAC settings, characteristic)

	<i>Frequency range</i>	<i>20°-30° C^{2,3,4}</i>
	22.0-40.0 GHz	+4.0-5.0 dB

Step gain

	<i>HP 70902A</i>	<i>20°-30° C</i>	<i>0°-55° C</i>
10 dB	±0.2 dB	±0.2 dB	±0.2 dB
20 dB	±0.2 dB	±0.2 dB	±0.2 dB
30 dB	±0.2 dB	±0.2 dB	±0.3 dB
40 dB	±0.2 dB	±0.2 dB	±0.5 dB
50 dB	±0.2 dB	±0.2 dB	±0.6 dB
60 dB	±0.4 dB	±0.4 dB	±0.8 dB
	<i>HP 70903A</i>		
10 dB			±0.1 dB
20 dB			±0.3 dB

Input attenuator

Absolute accuracy (characteristic)

Center frequency⁵

0.0-40 GHz ±1.8 dB

< ±0.2 dB variation for any setting

Attenuator repeatability

Spurious responses⁶

Inputs *Response*

10 MHz-40 GHz < -70 dBc

Second harmonic distortion⁷

Frequency *Response*

26.5-40.0 GHz < -70 dBc (characteristic)

Third-order intermodulation (20-30° C)

Center frequency *Intermod. products* *TOI*

□ HP 70902A	26.5-40.0 GHz	< -76 dBc	+8 dBm (characteristic)
□ HP 70903A	26.5-40.0 GHz	< -66 dBc	+8 dBm (characteristic)

¹ N = mixing harmonic number as defined under frequency band.

² With 10 dB attenuation.

³ Relative to 300 MHz calibrator (does not include calibrator amplitude error).

⁴ For spans ≤ 100 MHz, 50 to 70 dB range, referenced to the 10 dB setting.

⁵ 0 to 70 dB range, referenced to the 10 dB setting.

⁶ Except as listed below for ≤ -30 dBm total signal power at the RF input with 10 dB attenuation.

⁷ For ≤ -30 dBm total signal power at the RF input with 10 dB attenuation.

⁸ For two signals, each ≤ -20 dBm at the RF input with 10 dB attenuation.

⁹ TOI is degraded by 2 dB over 0° to 55° C temperature range.

¹⁰ For two signals, each ≤ -15 dBm at the RF input with 10 dB attenuation.

Spectrum Analyzers

Microwave Spectrum Analyzer

HP 71209A/P Option Z40

Amplitude cont.

Spurious responses

Image responses¹¹

Offset from input frequency	Response
(due to 21.4 MHz and 3 MHz IF) 6 or 42.8 MHz	-85 dBc
(due to 321.4 MHz) 642.8 MHz	-54 dBc

Residual responses¹²

Frequency	Response
26.5–40.0 GHz	<-78 dBm displayed

Multiple and out-of-band responses¹³

For inputs ≤ 26.5 GHz, all multiple responses (RF $\pm N \times$ LO) will be < -70 dBc.
For inputs > 26.5 GHz and ≤ 40.0 GHz, < -63 dBc¹⁴

Gain compression¹⁵

< 0.5 dB

Displayed average noise level¹⁵

Frequency	Noise level
100 Hz	< -92 dBm (char)
300 Hz	< -95 dBm (char)
1 kHz	< -101 dBm (char)
3 kHz	< -111 dBm (char)
10 kHz	< -118 dBm (char)
30 kHz	< -118 dBm (char)
100 kHz	< -122 dBm (char)
300 kHz	< -130 dBm (char)
1 MHz	< -139 dBm (char)
3 MHz	< -139 dBm (char)
10 MHz–2.0 GHz	-137 dBm
2.0–12.8 GHz	-136 dBm
12.6–22.0 GHz	-129 dBm
22.0–25.0 GHz	-127 dBm
25.0–26.5 GHz	-122 dBm
26.5–28.0 GHz	-104 dBm
28.0–40.0 GHz	-107 dBm

General specifications

Power requirements (characteristic)

<input type="checkbox"/> HP 70909A Option Z40 RF section	40 W
<input type="checkbox"/> HP 70590A Option Z40 RF section	0 W ¹⁶
<input type="checkbox"/> HP 71209A Option Z40 spectrum analyzer	329 W

Weight (characteristic)

<input type="checkbox"/> HP 70909A Option Z40 RF section	5.2 kg
<input type="checkbox"/> HP 70590A Option Z40 RF section	3.4 kg
<input type="checkbox"/> HP 71209A Option Z40 spectrum analyzer	54.7 kg

LO RAM hold time

Battery Life (characteristic)
1 year minimum at 25° C
6 months minimum at 55° C
> 1 year typical at 55° C

HP 70590A Option Z40 RF input connector (2.4 mm)

Frequency (characteristic) 100 Hz to 40.0 GHz

Maximum input level at attenuator

<input type="checkbox"/> AC (continuous)	+30 dBm with > 10 dB atten
<input type="checkbox"/> AC (peak power)	100 W, 10 ms pulse with > 50 dB atten
<input type="checkbox"/> DC	0 V
VSWR (> 10 dB attenuation)	
<input type="checkbox"/> 0 to 6.2 GHz (characteristic)	< 1.4
<input type="checkbox"/> 6.2–40.0 GHz (characteristic)	< 2.0
Impedance	50 Ω (nominal)

HP 70909A Option Z40 RF section connectors

1ST LO OUT connector

<input type="checkbox"/> Frequency range (characteristic)	3.0 to 6.6 GHz
<input type="checkbox"/> Output power (characteristic)	+2.6 to +14.9 dBm
<input type="checkbox"/> VSWR (characteristic)	< 2.4
<input type="checkbox"/> Impedance	50 Ω (nominal)

21.4 MHz OUT connector

<input type="checkbox"/> Center frequency (characteristic)	21.4 MHz
<input type="checkbox"/> Output power (characteristic)	0 dB input power
<input type="checkbox"/> 10 dB attenuation	-5 dBm
<input type="checkbox"/> VSWR (characteristic)	≤ 1.5
<input type="checkbox"/> Impedance	50 Ω (nominal)

300 MHz IN connector

<input type="checkbox"/> Frequency (characteristic)	300 MHz \pm 30 kHz
<input type="checkbox"/> Input power (characteristic)	-2.0 to +2.0 dBm
<input type="checkbox"/> Impedance	50 Ω (nominal)

321.4 MHz IF OUT connector

<input type="checkbox"/> Minimum preselected 3 dB bandwidth (characteristic)	7 MHz
<input type="checkbox"/> Output power (characteristic)	-5 dBm for -10 dBm input to mixer
<input type="checkbox"/> VSWR (characteristic)	< 1.5
<input type="checkbox"/> Impedance	50 Ω (nominal)

Noise declaration (for Germany)

LpA < 70 dB
am Arbeitsplatz (operator position)
normaler Betrieb (normal position)
nach DIN 45635 T. 19 (per ISO 7779)

Exceptions

Radiated susceptibility: In the presence of a 3 V/m field, measurement range is limited to -75 dBm for center frequencies < 26.5 GHz and -50 dBm for center frequencies > 26.5 GHz.

¹¹ For ≤ 10 dB input attenuation, RF input level ≤ 0 dBm; and signals displayed at 6 MHz, 42.8 MHz, and 642.8 MHz away from the applied signal frequency.

¹² With 0 dB input attenuation and no input signal.

¹³ For signal levels ≤ 0 dBm at the RF input with 10 dB attenuation.

¹⁴ N is any integer.

¹⁵ With 0 dB input attenuation, RF level ≤ -75 dBm, 10 Hz, 3 Hz Video BW.

¹⁶ Power supplied by HP 70909A Option Z40.

Spectrum Analyzers

Fundamentally Mixed Microwave Spectrum Analyzer HP 71210C/P

100 Hz to 22 GHz

-133 dBm sensitivity at 22 GHz

Dynamic tracking preselector

*10 Hz to 3 MHz resolution
bandwidths*

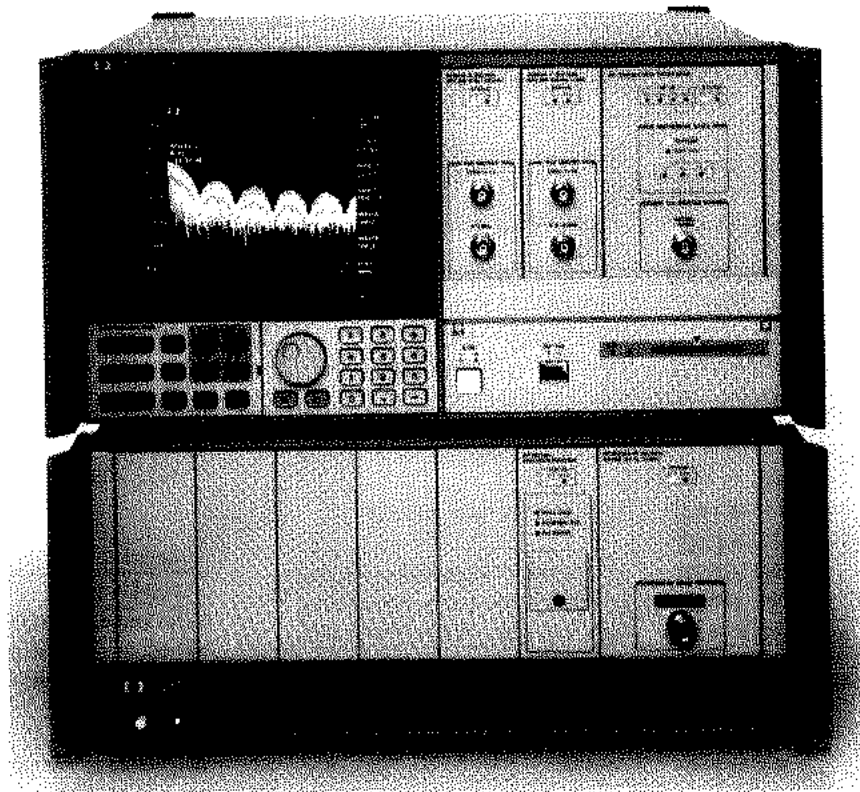

For top microwave performance, choose an HP 71210C/P spectrum analyzer. A dynamic tracking preselector keeps the analyzer peaked under all environmental conditions, not just compensated for frequency offset. Fundamental mixing provides sensitivity of -139 dBm at 1 GHz and -133 dBm at 22 GHz, which allows fast, accurate spurious-response measurements.

For even better sensitivity, add the HP 70620B preamplifier and get -150 dBm sensitivity at 22 GHz to measure extremely low level signals. The HP 70620B Option 001 offers similar sensitivity down to 100 kHz.

The HP 71210C/P has excellent frequency and amplitude accuracy. You get superb flatness throughout the frequency range, without time-consuming preselector peaking. Exceptional dynamic range results from the excellent sensitivity and low distortion front-end performance. The third-order intercept of the HP 71210C/P is +10 dBm from 10 MHz to 22 GHz.

Other systems based on HP 71210C/P modules are the component test system using tracking generators and the lightwave signal analyzer.

Refer to the HP 70000 Spectrum Analyzer Overview for more details.

Spectrum Analyzers

Fundamentally Mixed Microwave Spectrum Analyzer HP 71210C/P

Specifications

Specifications describe the instrument's warranted performance over the 0° to +55°C temperature range. Characteristics provide information about non-warranted instrument performance. Nominal values indicate the expected value of the parameter. All specifications apply after the instrument's temperature has been stabilized after a one-hour warm-up, self-calibration routines have been run, and the preselector peak function has been executed. Where specifications are subject to minimization with error-correction routines, corrected limits are given unless noted.

Frequency

Frequency range 100 Hz–22 GHz, tunable in 1 Hz increments

Frequency readout accuracy

Span ≤ 10 MHz x M¹ ± [(freq readout x freq ref acc) + 1.0% of span + 10 Hz]

Span > 10 MHz x M¹

Sweep ≥ 20 ms ± [(freq readout x freq ref acc) + 1.5% of span + 10 Hz]

Sweep ≥ 10 ms ± [(freq readout x freq ref acc) + 2.5% of span + 10 Hz]

Frequency span

Range 0–22 GHz in 0.5% increments

Accuracy

Span ≤ 10 MHz x M¹ ± [1% of span + (span x freq ref acc)]

Span > 10 MHz x M¹

Sweep ≥ 50 ms ± [1.5% of span + (span x freq ref acc)]

Sweep ≥ 20 ms ± [2.5% of span + (span x freq ref acc)]

Sweep ≥ 10 ms ± [4.0% of span + (span x freq ref acc)]

Frequency reference accuracy

	w/	w/o
	HP 70310A	HP 70310A
Aging	< 1 x 10 ⁻⁷ /year,	< 3 x 10 ⁻⁶ /year
	< 5 x 10 ⁻¹⁰ /day (7-day avg.)	

Temperature drift < 7x10⁻⁹ < 1 x 10⁻⁵

Spectral purity²

Frequency range	<i>Noise sideband</i>	<i>Offset</i>
<input type="checkbox"/> 100 Hz–2.9 GHz	-108 dBc/Hz	10 kHz
<input type="checkbox"/> 2.7–6.2 GHz	-108 dBc/Hz	30 kHz
<input type="checkbox"/> 6.0–12.8 GHz	-102 dBc/Hz	30 kHz
<input type="checkbox"/> 12.6–22 GHz	-96 dBc/Hz	30 kHz

Line and system related sidebands < -65 dBc + 20 log M¹

Residual FM

Span > 10 MHz x M¹ < 25 kHz p-p in 0.1 s (measurement BW=100 kHz)

Span ≤ 10 MHz x M¹ Determined from phase-noise sidebands

Frequency drift For spans > 10 MHz x M¹, freq. drift is ±1 kHz/s and ±150 kHz/°C. Errors due to drift are not cumulative sweep to sweep.

Sweep time

Range (continuous) 10 ms to 1000 s

Accuracy ± 2%

With HP 70700A Swept freq spans: 15 ms to 355 s
Fixed freq (zero span): 80 μs to 355 s with 800 point trace

Trigger Free run, line, video, external

Resolution bandwidth (3 dB, synchronously tuned)

Range 10 Hz–300 kHz (HP 70902A)

(1, 3, 10 sequence and 10% increments except 3 kHz–10 kHz)

Accuracy ±20%

Selectivity (-60 dB/-3 dB)

Bandwidth

10 Hz–3 kHz < 12:1

10 kHz–3 MHz < 16:1

Video bandwidth

Range 3 Hz–300 kHz (HP 70902A)

(1, 3, 10 sequence) 300 Hz–3 MHz (HP 70903A)

When set to maximum (300 kHz or 3 MHz), effective bandwidth is greater than specified.

Accuracy ±20% (characteristic)

Amplitude

Total amplitude range -139 to +30 dBm

Maximum safe input power

AC average continuous +30 dBm (≥ 10 dB attn)

Pulse power 100 W, 10 μs pulse (≥ 40 dB attn)

DC 0 V

Displayed average noise level

	<i>Frequency</i>	<i>DANL</i>
10 Hz res BW, 0 dB	10 MHz–2.9 GHz	-139 dBm
attn 3 Hz Video BW	2.7 GHz–12.8 GHz	-136 dBm
Ref level ≥ -85 dBm	12.6 GHz–22 GHz	-133 dBm
With HP 70620B	1.0–2.9 GHz	-155 dBm
	2.7–12.8 GHz	-153 dBm
	12.6–22.0 GHz	-150 dBm

Gain compression level (< 0 dB input attn) < 0.5 dB for signal levels ≤ -10 dBm

Spurious responses

	<i>Input</i>	<i>Spurious</i>
for input level ≤ -40 dBm at the input mixer, except as listed, are less than these values (10 dB attn)	100 Hz–10 MHz	< -60 dBc
	10 MHz–22 GHz	< -70 dBc

Second harmonic distortion

	<i>Band</i>	<i>Second harmonic</i>
for mixer input	100 Hz–20 MHz	< -60 dBc
≤ -40 dBm (10 dB attn)	20 MHz–3.5 GHz	< -70 dBc
	3.5 GHz–22 GHz	< -100 dBc

Third-order intermodulation distortion

	<i>Center frequency</i>	<i>Intermod products</i>	<i>Equiv TOI</i>
HP 70902A IF section³	100 Hz–10 MHz	< -66 dBc	+3 dBm
	10 MHz–22 GHz	< -80 dBc	+10 dBm
HP 70903A IF section³	100 Hz–10 MHz	< -56 dBc	+3 dBm
	10 MHz–22 GHz	< -70 dBc	+10 dBm

¹ M is the harmonic multiplier number; M=1 from 100 Hz to 6.2 GHz, M=2 from 6.0 GHz to 12.8 GHz, M=4 from 12.6 to 22 GHz.

² Refer to Figure 1 in the Spectrum Analyzer Overview for typical phase noise.

³ for two signals, each ≤ -30 dBm at the input mixer (10 dBm attn).

Spectrum Analyzers

Fundamentally Mixed Microwave Spectrum Analyzer HP 71210C/P

Amplitude cont.

Image responses

for RF input levels ≤ 0 dBm	Center freq (GHz)	Image responses (dBc)		
		6 MHz	42.8 MHz	642.8 MHz
	0-2.9	< -85	< -85	NA
	2.7-6.2	< -85	< -85	< -83
	6.0-12.8	< -85	< -85	< -73
	12.6-16.0	< -85	< -85	< -70
	16.0-22.0	< -85	< -85	< -58

Residual responses (0 dB attn, input terminated)	Range	Responses
	10 MHz-22 GHz	< -100 dBm

Multiple responses < -60 dBc

for inputs ≤ 22 GHz
and RF levels ≤ 0 dBm
(≥ 10 dB attn)

Display range (10 divisions)

Calibration

<input type="checkbox"/> Log	0.01-20 dB/div in 0.5% increments
<input type="checkbox"/> Linear	0 to 10% of reference level per division

Reference level range

<input type="checkbox"/> Log	+30 to -140 dBm
<input type="checkbox"/> Linear	7.07 V to 22 nV

Frequency response	Band	20° to		0° to	
		30° C	50° C	30° C	50° C
Peak variation (10 dB attn)	100 Hz-2.9 GHz	± 1.5 dB	± 2.0 dB	± 2.0 dB	± 2.5 dB
	2.7-22 GHz	± 2.0 dB	± 2.5 dB		
Referenced to 300 MHz, -10 dBm calibrator (10 dB attn)	100 Hz-2.9 GHz	± 2.3 dB			
	2.7 GHz-22 GHz	± 3.3 dB			

Calibrator uncertainty ± 0.3 dB (-10 dBm, 300 MHz)

Input attenuator switching repeatability

± 0.2 dB

IF gain accuracy	Gain	20° to		0° to	
		30° C	50° C	30° C	50° C
	10 dB	± 0.2 dB	± 0.2 dB	± 0.2 dB	± 0.2 dB
	20 dB	± 0.2 dB	± 0.2 dB	± 0.2 dB	± 0.2 dB
	30 dB	± 0.2 dB	± 0.2 dB	± 0.3 dB	± 0.3 dB
	40 dB	± 0.2 dB	± 0.2 dB	± 0.5 dB	± 0.5 dB
	50 dB	± 0.2 dB	± 0.2 dB	± 0.6 dB	± 0.6 dB
(HP 71210C/P only)	60 dB	± 0.4 dB	± 0.4 dB	± 0.8 dB	± 0.8 dB

Scale fidelity

Log corrected (1-3-10)

HP 70902A 10 Hz ± 0.7 dB

(0 to 90 dB) 30 Hz-100 kHz ± 0.5 dB

HP 70903A 300 kHz-1 MHz ± 0.5 dB

(0 to 75 dB) 3 MHz ± 0.7 dB

Log, uncorrected All ± 3.0 dB

Incremental, corrected All ± 0.1 dB/1 dB

Linear ± 7.5% of reference level

Amplitude cont.

Amplitude temperature drift (nominal)	± 0.05 dB/° C
-10 dBm ref level, 10 dB input attn, 100 Hz res BW (HP 70902A IF)	(Accumulated error is eliminated by running internal correction routine.)
300 kHz res BW (HP 70903A IF)	

Resolution bandwidth

Switching repeatability	
in 1, 3, 10 sequence	± 0.2 dB
	± 3 dB (uncorrected)

Marker resolution

± 0.03 dB

Input/output characteristics

Front panel only; see module characteristics for more detailed information.

HP 70900B LO section 300 MHz calibrator

Output	BNC (f), 50 Ω (nominal)
Output power	-10 dBm ± 0.3 dB
Frequency accuracy	300 MHz x freq ref accuracy

HP 70908A RF section (100 Hz to 22 GHz)

RF Input	Type-N (f), 50 Ω (nominal)	
LO emissions (10 dB attn)	< -100 dBm low band (0 - 2.9 GHz), nominal < -50 dBm high band (2.7 - 22 GHz), nominal	
VSWR (≥ 10 dB attn)	Freq (GHz)	VSWR (nominal)
	0-12.8	< 1.9:1
	12.8-18.0	< 2.3:1
	18.0-22.0	< 2.5:1

HP 70902A IF section

Auxiliary video output	BNC (f), 0-1 V, 1 k-Ω (nominal)
3 MHz IF output (linear)	BNC (f), 50 Ω, 1.5:1 VSWR (nominal)
Output power	-15 dBm nominal with -5 dBm RF input, 0 dB attn and -10 dBm ref level

HP 70903A IF section

Auxiliary Video Output	BNC (f), 0 - 1 V, 100 Ω (nominal)
------------------------	-----------------------------------

HP-IB Codes SH1 AH1 T6 L4 SR1 RL1 DC1 PP0 DT1 E2 C1

Spectrum Analyzers

Fundamentally Mixed Microwave Spectrum Analyzer HP 71210C/P

General specifications

HP 71210C system components

- HP 70001A
- HP 70004A
- HP 70900B
- HP 70310A
- HP 70902A
- HP 70903A
- HP 70908A

HP 71210P system components

- HP 70001A
- HP 70207B E05
- HP 70900B
- HP 70310A
- HP 70902A
- HP 70903A
- HP 70908A

(NOTE: When adding or exchanging modules, be sure that the final count will fit into the 8-slot HP 70001A mainframe and the 4-slot HP 70004A display/mainframe.)

Environmental temperature: Operational, 0° to +55° C; storage, -40° to +75° C

Humidity: Operational, 0 to 95% relative humidity at 45° C

EMC: Conducted and radiated interference is in compliance with CISPR pub 11, FTZ 526/1979, and MIL-STD 461B, RE02/part 7.

Vibration and shock: In compliance with MIL-T-28800E Type III Class 3

Power requirements: See requirements for HP 70001A and HP 70004A. All power requirements supplied by the mainframe (HP 70001A or 70004A).

Weight (nominal), HP 71210C/P standard: 52.5 kg (115.8 lb)

Dimensions

- HP 70001A mainframe: 177.0 mm (6.97") high, 425.4 mm (16.75") wide, 526.0 mm (20.7") long
- HP 70004A display: 222.0 mm (8.74") high, 425.4 mm (16.75") wide, 526.0 mm (20.7") long

Warranty: 1 year (extendible with options)

Calibration cycle: 3 years recommended

Features and compatibility

HP 70004A system features used: Memory card, direct-to-disk, keyboard (for title mode and writing small DLPs), direct plot (buffered), direct print, color display

Mass storage

Memory card: 32 KB or 128 KB RAM per card

External: SS80-compatible hard or flexible disk

User memory: 128 KB minimum (32 KB minimum with firmware before 901008), about 2.5 KB to store an 800 point trace with its state. System memory is reduced when slave modules are added. Optional 1 MB memory.

Compatible accessory modules (slave modules to the HP 70900B master module)

- HP 70621A/HP 70620B preamplifiers
- HP 70300A/HP 70301A tracking generators
- HP 70810A lightwave section (master module)
- HP 70907B external mixer interface module
- HP 70700A digitizer (slave mode)
- HP 70205A display

Software available from HP

- HP 11990A performance verification software
- HP 70871A scalar measurement personality

Ordering Information

HP 71210C spectrum analyzer

Option 1BH general export license version, span limited to 2.3 GHz, maximum frequency of 18 GHz

Option 1BN certificate of calibration

Option 1BP certificate of calibration and data

Option 006 delete HP 70902A 10 Hz - 300 kHz IF section

Option 007 delete HP 70903A 100 kHz-3 MHz IF section

Option 110 delete HP 70310A precision frequency reference

Option 121 add distribution amplifier on the HP 70310A precision frequency reference (HP 70310A/001)

Option 122 provide external reference capability and delete ovenized reference in the HP 70310A

Option 200 delete display (operation and control over HP-IB only)

Option 205 substitute HP 70205A display for HP 70004A display/mainframe

Option 400 add 400 Hz power line frequency operation to the HP 70001A mainframe; adds isolation transformer at 2.3 kg (5 lb)

Option 512 additional memory, 1 MB total, 90 KB user memory

Option 810 rack mount slide kit for both the HP 70001A mainframe and the HP 70004A display/mainframe

Option 908 rack flange kit to mount HP 70001A/HP 70004A without handles

Option 910 extra user manual set containing (a) installation/verification, (b) operation, and (c) program language reference

Option 913 rack flange kit to mount HP 70001A/HP 70004A with handles attached

Option 915 service manual set and software for troubleshooting and repair

HP 71210P spectrum analyzer

Option 1BN certificate of calibration

Option 1BP certificate of calibration and data

Option 006 delete HP 70902A 10 Hz-300 kHz IF section

Option 007 delete HP 70903A 100 kHz-3 MHz IF section

Option 010 add HP 70001A mainframe

Option 110 delete HP 70310A precision frequency reference

Option 121 add distribution amplifier on the HP 70310A precision frequency reference (HP 70310A/001)

Option 122 provide external reference capability and delete ovenized reference in the HP 70310A

Option 660 add HP 8566B programming manual kit

Option 910 extra user manual set containing (a) installation/verification, (b) operation, and (c) program language reference

Option AX4 rack flange kit

Option AXE rack flange kit with handle

Spectrum Analyzers

Upgrade Kits

HP 70860A/70861A

*Upgrade kits for the
HP 70900A/B local oscillator*

*Speed up your modular
spectrum analyzers*

*Store directly to
memory card or disk*

*Display using analog-
quality digital persistence*

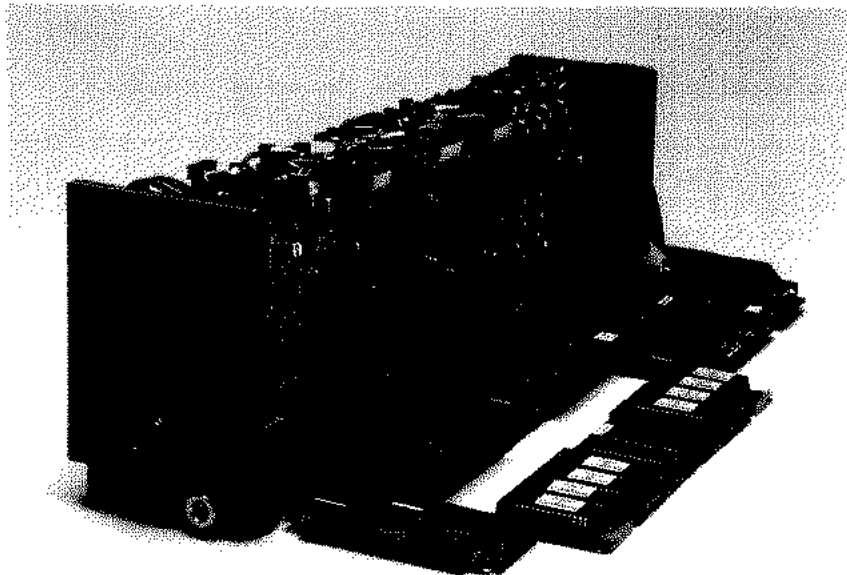

High speed and new firmware
The HP 70860A high speed controller board approximately doubles the speed of any RF, microwave, or millimeter modular spectrum analyzer that contains the HP 70900A local oscillator.

The HP 70860A also contains new firmware, available separately as the HP 70861A RAM/ROM upgrade kit. These kits upgrade your HP 70900A, providing the same firmware features as the HP 70900B, the master control module of the HP 70000C series modular spectrum analyzers.

HP 70860A high speed controller board upgrade kit

The HP 70860A uses the Motorola 68020 microprocessor and a 68881 floating point coprocessor operating at 20 MHz. (The previous rate was 10 MHz.)

Plugged into your HP 70900A, the HP 70860A is a powerful, high speed instrument controller. Processing speed is 1.5 to 3 times faster than before. Your upgraded system operates at 90% the speed of the HP 70900B local oscillator.

Local oscillator tuning speed, time between sweeps, sweep time, math functions, and internal processing are all improved.

High throughput measurements

Speed improvements, combined with the excellent accuracy and repeatability of the modular analyzer hardware, means higher throughput. You'll save time in your automatic tests.

Plus, the HP 70860A includes all the benefits of the HP 70861A.

HP 70861A RAM/ROM board upgrade kit

The HP 70861A contains new firmware loaded into high speed ROM. You can transfer data directly to a disk. Take full advantage of the HP 70004A color display by using memory cards, the hardkey panel and the analog-quality digital persistence display mode.

Memory card and external disks

The firmware allows the spectrum analyzer to read and write to external disks or to the memory card in the HP 70004A display. A computer is not required. You can save and recall

traces, states, downloadable programs (DLP's), and limit lines. Simply indicate the storage device desired: memory card, external disk, or internal memory (32 KB).

For a standard 1/4 MB ROM/RAM board, the user has access to more than 32 KB. It depends upon configuration, but normal configuration provides greater than 200 KB.

Option 512 for either kit extends the internal memory to 1 MB.

Digital persistence display

The firmware adds digital persistence to the HP 70004A color display. Extract information from complex modulated signals, such as TV, pulsed RF, and FM.

Digital persistence simulates the variable intensities of analog displays, without sacrificing the storage and plotting capabilities of digital displays.

Spectrum Analyzers

Upgrade Kits

HP 70860A/70861A

New speed commands

New commands speed up automated programs. The **OVERSWEEP** command allows auto-coupled sweep times up to five times faster with minimal amplitude degradation. The **FETCH** command transfers data over HP-IB simultaneously with transfer to the display.

Compatibility

Firmware is easily upgraded, regardless of which revision you currently have. The following table identifies which upgrade kit is required (HP 70860A, 70861A). You can install the upgrade yourself, or have it installed at any HP service center. Simply run the internal calibration (CAL ALL) after installation.

Module compatibility for firmware ROM version

The following information details each firmware version for the HP 70900A and 70900B local oscillator. This firmware contains the operating characteristics of the spectrum analyzers. The table shows which modules each firmware revision supports. After the initial version, new modules are indicated by *italics*. Firmware revisions are now documented using the version update fix (VUF) format (for example A.00.00). Both the VUF and datecode (for example 850730) are shown for all revisions in this list. The VUF format is available from the instrument via the front panel beginning with revision B.04.02. (See also the "IDN?" remote command.)

For each revision, the approximate available memory is indicated, along with information on major changes for the revision. Listed also is the product required to upgrade the firmware to the current revision. To determine your current revision, press the [MENU] hardkey, then <misc>, <service>, and <ROM VERSION> softkeys for later revisions, or press the [MENU] hardkey, then <CONFIG> and <ROM VERSION> softkeys for early revisions.

	Models
Datecode 850730 Revision A.00.00 <input type="checkbox"/> Usable RAM memory is 8K. <input type="checkbox"/> Upgrade: HP 70860A	70205A, 70206A, 70310A, 70900A, 70902A, 70903A, 70904A, 70905A, 70905B, 70906A, 70906B
Datecode 860203 Revision A.01.00 <input type="checkbox"/> Usable RAM memory is 8K. <input type="checkbox"/> Upgrade: HP 70860A	70205A, 70206A, 70300A , 70310A, 70900A, 70902A, 70903A, 70904A, 70905A, 70905B, 70906A, 70906B, 70907A
Datecode 861015 Revision A.02.00 <input type="checkbox"/> Usable RAM memory is 16K. <input type="checkbox"/> Upgrade: HP 70860A	70205A, 70206A, 70300A, 70310A, 70600A, 70601A , 70900A, 70902A, 70903A, 70904A, 70905A, 70905B, 70906A, 70906B, 70907A
Datecode 870501 Revision A.03.00 <input type="checkbox"/> Usable RAM memory is 32K. <input type="checkbox"/> Upgrade: HP 70860A	70205A, 70206A, 70300A, 70310A, 70600A, 70601A, 70700A , 70900A, 70902A, 70903A, 70904A, 70905A, 70905B, 70906A, 70906B, 70907A, 70908A
Datecode 880314 Revision B.00.00 <input type="checkbox"/> Usable RAM memory is 32K. <input type="checkbox"/> Upgrade: HP 70860A This revision introduced the new menu style, with firmkeys on the left.	70205A, 70206A, 70300A, 70310A, 70600A, 70601A, 70620A, 70700A, 70810A , 70900A, 70902A, 70903A, 70904A, 70905A, 70905B, 70906A, 70906B, 70907A, 70908A
Datecode 880901 Revision B.01.00 <input type="checkbox"/> Usable RAM memory is 32K. <input type="checkbox"/> Upgrade: HP 70860A	70205A, 70206A, 70300A, 70301A , 70310A, 70600A, 70601A, 70620A, 70700A, 70810A, 70900A, 70902A, 70903A, 70904A, 70905A, 70905B, 70906A, 70906B, 70907A, 70908A

	Models
Datecode 890606 Revision B.02.00 <input type="checkbox"/> Usable RAM memory is 32K. <input type="checkbox"/> Upgrade: HP 70861A	70004A, 70205A, 70206A, 70300A, 70301A, 70310A, 70600A, 70601A, 70620A, 70700A, 70810A, 70900A, 70900B , 70902A, 70903A, 70904A, 70905A, 70905B, 70906A, 70906B, 70907A, 70908A
Datecode 891102 Revision B.02.01 <input type="checkbox"/> Usable RAM memory is 32K. <input type="checkbox"/> Upgrade: HP 70861A	70205A, 70206A, 70300A, 70301A, 70310A, 70600A, 70601A, 70620A, 70700A, 70810A, 70900A, 70900B, 70902A, 70903A, 70904A, 70905A, 70905B, 70906A, 70906B, 70907A, 70908A
Datecode 900314 Revision B.03.00 <input type="checkbox"/> Usable RAM memory is 32K. <input type="checkbox"/> Upgrade: HP 70861A	70205A, 70206A, 70300A, 70301A, 70310A, 70600A, 70601A, 70620A, 70620B, 70621A , 70700A, 70810A, 70900A, 70900B, 70902A, 70903A, 70904A, 70905A, 70905B, 70906A, 70906B, 70907A, 70907B , 70908A
Datecode 901008 Revision B.03.01 <input type="checkbox"/> Usable RAM memory is 128K, with 700K available as Option 512. <input type="checkbox"/> Upgrade: HP 70861A or HP 70861A Option 512. Able to support special personalities.	70004A, 70205A, 70206A, 70300A, 70301A, 70310A, 70600A, 70601A, 70620A, 70620B, 70621A, 70700A, 70810A, 70900A, 70900B, 70902A, 70903A, 70904A, 70905A, 70905B, 70906A, 70906B, 70907A, 70907B, 70908A

Spectrum Analyzers

Upgrade Kits

HP 70860A/70861A

Models	
Datecode 918802	70004A, 70205A, 70206A, 70300A,
Revision B.04.00	70301A, 70310A, 70600A, 70601A,
<input type="checkbox"/> Usable RAM memory is 128K, with 700K available as Option 512.	70620A, 70620B , 70621A , 70700A,
<input type="checkbox"/> Upgrade: HP 70861A or HP 70861A-512 if desired.	70810A, 70810B, 70900A, 70900B,
Programming compatibility with the HP 8566B is supported.	70902A, 70903A, 70904A, 70905A,
Datecode 911021	70905B, 70906A, 70906B, 70907A,
Revision B.04.01	70907B, 70908A, 70909A , 70910A
<input type="checkbox"/> Usable RAM memory is 128K, with 700K available as Option 512.	70004A, 70205A, 70206A, 70300A,
<input type="checkbox"/> Upgrade: HP 70861A, or HP 70861A-512.	70301A, 70310A, 70600A, 70601A,
Datecode 920325	70620A, 70620B, 70621A, 70700A,
<input type="checkbox"/> Usable RAM memory is 128K, with 700K available as Option 512.	70810A, 70810B, 70900A, 70900B,
<input type="checkbox"/> Upgrade: HP 70861A or HP 70861A-512.	70902A, 70903A, 70904A, 70905A,
This revision is used in the HP 70950A and HP 70951A only.	70905B, 70906A, 70906B, 70907A,
	70907B, 70908A, 70909A, 70910A

Models	
Datecode 920724	70004A, 70205A, 70206A, 70300A,
Revision B.04.04	70301A, 70310A, 70600A, 70601A,
<input type="checkbox"/> Usable RAM memory is 128K, with 700K available as Option 512.	70620A, 70620B, 70621A, 70700A,
<input type="checkbox"/> Upgrade: HP 70861A, or HP 70861A-512.	70810A, 70810B, 70900A, 70900B,
Datecode 940120	70902A, 70903A, 70904A, 70905A,
Revision B.05.00	70905B, 70906A, 70906B, 70907A,
<input type="checkbox"/> Usable RAM memory is 128K, with 700K available as Option 512.	70907B, 70908A, 70909A, 70910A
<input type="checkbox"/> Upgrade: HP 70861A, or HP 70861A-512.	70004A, 70205A, 70206A, 70300A,
Datecode 960418	70301A, 70310A, 70600A, 70601A,
Revision B.06.03	70620A, 70620B, 70621A, 70700A,
<input type="checkbox"/> Usable RAM memory is 128K, with 700K available as Option 512.	70810A, 70810B, 70900A, 70900B,
<input type="checkbox"/> Upgrade: HP 70861A, or HP 70861A-512.	70902A, 70903A, 70904A, 70905A,
	70905B, 70906A, 70906B, 70907A,
	70907B, 70908A, 70909A, 70910A,
	70911A

Ordering Information

HP 70860A high speed controller board upgrade kit

HP 70861A RAM/ROM board upgrade kit

Option 512 1 MB memory

Option 871 scalar personality

Spectrum Analyzers

Upgrade Kits

The HP 70900A/B local oscillator is the master control module for many different spectrum analyzer systems. These systems have compatibility requirements for firmware, hardware, and software. Requirements are listed below.

The latest local oscillator firmware will not work in the MEM Plus controller boards, which were used only in the HP 70900A. The part

numbers of these boards are 70900-60078, 70900-60081, and 70900-60111.

To determine the compatibility of a controller board, press the **Extended State** softkey. If the letters CPU are followed by the figure 68020, and if the letters FPU are followed by the word "Present," then the new firmware will work with the controller board.

Compatibility

To upgrade the LO firmware, order the HP 70861A. This kit includes a ROM/RAM board along with the latest documentation.

If the controller board needs to be upgraded, order the HP 70860A. This kit includes a controller board, ROM/RAM board, and the latest documentation.

HP 70900A firmware history

HP 70900A firmware version 850320 (initial release)

- HP 70900A serial numbers 2429A00101/2429A00265 (controller/ROM/RAM board, HP part number 70900-60078)

Additional modules supported

- HP 70205A graphics display
- HP 70206A system graphics display
- HP 70310A precision frequency reference
- HP 70902A IF section (resolution bandwidth 10 Hz to 300 kHz)
- HP 70903A IF section (resolution bandwidth 100 kHz to 3 MHz)
- HP 70904A RF section (100 kHz to 2.9 GHz)
- HP 70905A RF section (50 kHz to 22 GHz)
- HP 70905B RF section (50 kHz to 22 GHz)
- HP 70906A RF section (50 kHz to 26.5 GHz)
- HP 70906B RF section (50 kHz to 26.5 GHz)

HP 70900A firmware version 850730

- HP 70900A serial numbers 2534A00266/2544A00547 (ROMs only, HP part number 70900-60093; controller/ROM/RAM board, HP part number 70900-60078)

Additional modules supported

None

System diagnostics

- HP part number 5010-1507 (3 1/2 inch disk)
- HP part number 5010-1508 (5 1/4 inch disk)

System operation verification

- HP part number 70900-10037, rev. B.03.01 (3 1/2 inch disk)
- HP part number 70900-10038, rev. B.03.01 (5 1/4 inch disk)

HP 70900A firmware version 860203

- HP 70900A serial numbers 2606A00548/2629A01183 (ROMs only, HP part number 70900-60086; controller/ROM/RAM board, HP part number 70900-60078)

Additional modules supported

- HP 70300A tracking generator
- HP 70907A external mixer interface module

System diagnostics

- HP part number 5010-1507 (3 1/2 inch disk)
- HP part number 5010-1508 (5 1/4 inch disk)

System operation verification

- HP part number 70900-10037, rev. B.03.01 (3 1/2 inch disk)
- HP part number 70900-10038, rev. B.03.01 (5 1/4 inch disk)

HP 70990A firmware version 861015 (MEM Plus hardware)

- HP 70900A serial numbers 2642A01184/2646A01429 (ROM/RAM plug-in board, HP part number 70900-60083; controller board MEM+, HP part number 70900-60081)

Additional modules supported

- HP 70590A H69 MATE test module adapter
- HP 70600A preselector (50 kHz to 22 GHz)
- HP 70601A preselector (50 kHz to 26.5 GHz)

System diagnostics

- HP part number 70900-10050 (3 1/2 inch disk)

System operation verification

- HP part number 70900-10051, rev. C.01.00 (3 1/2 inch disk)

HP 70900A firmware version 870501

- HP 70900A serial numbers 2717A01430/2812A01885 (ROM/RAM plug-in board, HP part number 70900-60109; controller board MEM+, HP part number 70900-60111)

Additional modules supported

- HP 70700A digitizer
- HP 70908A preselected RF section (100 Hz to 22 GHz)

System diagnostics

- HP part number 70900-10050 (3 1/2 inch disk)

System operation verification

- HP part number 70900-10051, rev. C.01.00 (3 1/2 inch disk)

HP 70900A firmware version 880314

- HP 70900A serial numbers 2817A01886/2833A02083 (ROM/RAM plug-in board, HP part number 70900-60114; controller board MEM+, HP part number 70900-60111)

Additional modules supported

- HP 70620A preamplifier

System diagnostics

- HP part number 70900-10050 (3 1/2 inch disk)
- System operation verification
- HP part number 70900-10051, rev. C.01.00 (3 1/2 inch disk)

Spectrum Analyzers

Upgrade Kits

Compatibility

HP 70900A firmware version 880901

- ❑ HP 70900A serial numbers 2841A02084/3019A02763 (ROM/RAM plug-in board, HP part number 70900-60126; controller board MEM +, HP part number 70900-60111)

Additional modules supported

HP 70301A tracking generator (2.7 to 18 GHz)

System diagnostics

HP part number 70900-10050 (3 ½ inch disk)

System operation verification

HP part number 70900-10051, rev. C.01.00 (3 ½ inch disk)

HP 70900A/B firmware version 890606

- ❑ HP 70900A serial numbers above prefix 3019A
- ❑ HP 70900B serial numbers 2923A00101/2923A00389 (ROM/RAM board, HP part number 70900-60130; controller board, HP part number 70900-60082)

Additional modules supported

HP 70900B local oscillator

System diagnostics

HP part number 70900-10050 (3 ½ inch disk)

System operation verification

HP part number 70900-10051, rev. C.01.00 (3 ½ inch disk)

HP 70900A/B firmware version 891102

- ❑ HP 70900A serial numbers above prefix 3019A
- ❑ HP 70900B serial numbers 3001A00390/3002A00557 (ROM/RAM board, HP part number 70900-60148; controller board MEM ++, HP part number 70900-60143)

Additional modules supported

None

System diagnostics

HP part number 70900-10050 (3 ½ inch disk)

System operation verification

HP part number 70900-10051, rev. C.01.00 (3 ½ inch disk)

HP 70900A/B firmware version 900314

- ❑ HP 70900A serial numbers above prefix 3019A
- ❑ HP 70900B serial numbers 3022A00558/3022A00707 (ROM/RAM board, HP part number 70900-60156; controller board, HP part number 70900-60143)

Additional modules supported

HP 70621A preamplifier (100 kHz to 2.9 GHz)
HP 70620B preamplifier (1 to 26.5 GHz)
HP 70907B external mixer interface module

System diagnostics

HP part number 70900-10050 (3 ½ inch disk)

System operation verification

HP part number 70900-10051, rev. C.01.00 (3 ½ inch disk)

HP 70900A/B firmware version 901008

- ❑ HP 70900A serial numbers above prefix 3019A
- ❑ HP 70900B serial numbers 3041A00708/3127A01115 (ROM/RAM board 256 KB RAM, HP part number 70900-60160; ROM/RAM board 1 MB RAM, HP part number 70900-60159; controller board, HP part number 70900-60143)

Additional modules supported

None

System diagnostics

HP part number 70900-10050 (3 ½ inch disk)

System operation verification

HP part number 70900-10051, rev. C.01.00 (3 ½ inch disk)

HP 70900A/B firmware version 910802

- ❑ HP 70900A serial numbers above prefix 3019A
- ❑ HP 70900B serial numbers 3135A01116/3135A01183 (ROM/RAM assembly, 256 KB RAM, HP part number 70900-60171; ROM/RAM assembly, 1 MB RAM, HP part number 70900-60172; controller board, HP part number 70900-60143)

Additional modules supported

HP 70810B lightwave section

System diagnostics

HP part number 70900-10053 (3 ½ inch disk)

System operation verification

HP part number 70900-10052, rev. C.02.00 (3 ½ inch disk)

Spectrum Analyzers

Upgrade Kits

Compatibility

HP 70900A/B firmware version 911021

- HP 70900A serial numbers above prefix 3019A
- HP 70900B serial numbers 3144A01184/3222A01427 (ROM/RAM assembly, 256 KB RAM, HP part number 70900-60176; ROM/RAM assembly, 1 MB RAM, HP part number 70900-60177; controller board, HP part number 70900-60143)

Additional modules supported

HP 70909A RF section (100 Hz to 26.5 GHz)
HP 70910A RF section (100 Hz to 26.5 GHz)

Additional systems supported

HP 71209A microwave spectrum analyzer (100 Hz to 26.5 GHz)

System diagnostics

HP part number 70900-10053 (3 1/2 inch disk)

System operation verification

HP part number 70900-10052, rev. C.02.00 (3 1/2 inch disk)

HP 70900A/B firmware version (VV.UU.FF)

B.04.03 920527

- HP 70900A serial numbers above prefix 3019A
- HP 70900B serial numbers 3224A01428/3224A01469 (ROM/RAM assembly, 256 KB RAM, HP part number 70900-60195; ROM/RAM assembly, 1 MB RAM, HP part number 70900-60196; controller board, HP part number 70900-60143)

Additional modules supported

HP 70900B (A7) fractional frequency synthesizer

Additional systems supported

None

System diagnostics

HP part number 70900-10053 (3 1/2 inch disk)

System operation verification

HP part number 70900-10052, rev. C.02.00 (3 1/2 inch disk)

HP 70900A/B firmware version (VV.UU.FF)

B.04.04 920724

- HP 70900A serial numbers above prefix 3019A
- HP 70900B serial numbers 3232A01470/3345A01967 (ROM/RAM assembly, 256 KB RAM, HP part number 70900-60199; ROM/RAM assembly, 1 MB RAM, HP part number 70900-60200; controller board, HP part number 70900-60143)

Additional modules supported

None

Additional systems supported

None; system error corrected

System diagnostics

HP part number 70900-10056, rev. D.01.00 (3 1/2 inch disk)

System operation verification

HP part number 70900-10055, rev. D.01.00 (3 1/2 inch disk)
HP 1990A system performance test software, rev. D.01.00

Option 001 user interface 11990-10077

Option 100 HP 7100011990-10078

Option 200 HP 71200/7120111990-10079

Option 209 HP 7120911990-10081

Option 210 HP 7121011990-10080

Option 300 HP 7130011990-10082

Option 033 HP 70300/7030111990-10083

HP 70900A/B firmware version (VV.UU.FF)

B.05.00 940120

- HP 70900A serial numbers above prefix 3019A
Note: Must have a 70900-60143 controller board or later.
- HP 70900B serial numbers 3414A01968 to present (ROM/RAM assembly, 256 KB RAM, HP part number 70900-60203; ROM/RAM assembly, 1 MB RAM, HP part number 70900-60204; controller board, HP part number 70900-60143)

Additional modules supported

HP 70911A IF module

Additional systems supported

HP 71910A receiver system

HP 70900A/B firmware version (VV.UU.FF)

B.06.03 960418

- HP 70900A serial numbers above prefix 3019A
Note: Must have a 70900-60143 controller board or later.
- HP 70900B serial numbers 3414A01968 to present (ROM/RAM assembly, 256 KB RAM, HP part number 70800-60209; ROM/RAM Opt. 512 assembly, 1 MB RAM, HP part number 70900-60210; controller board, HP part number 70900-60213)

Additional modules supported

HP 70911A IF module

Additional systems supported

HP 71910A receiver system

Spectrum Analyzers

Preamplifiers

HP 70620B/70621A

HP 70621A, 100 kHz to 2.9 GHz

HP 70620B, 1 to 26.5 GHz
Option 001, 100 kHz to 26.5 GHz

-156 dBm sensitivity at 2.9 GHz

-150 dBm sensitivity at 22 GHz

Receiver quality noise figure
Boost the sensitivity of any HP 70000 spectrum analyzer by 15 to 25 dB using the HP 70620B or 70621A preamplifiers. For RF applications, a -134 dBm sensitivity improves to -156 dBm. For microwave applications, a -133 dBm sensitivity improves to -150 dBm at 22 GHz. System noise figure can be better than 8 dB to 2.9 GHz, 11 dB to 12.8 GHz, and 14 dB at higher frequencies.

Measure low level signals
Preamplification extends spectrum analyzer performance for many applications that require a low noise figure: spurious testing, low level signal measurements from antennas, broadband signal detection such as pulsed RF or electromagnetic interference signals, and noise figure component testing.

Faster measurements
Spurious measurement test times can be reduced from days to hours or from hours to minutes. The low system noise figure allows you to use a wider resolution bandwidth than before, yet achieve the same sensitivity. Sweep times can improve 100-fold for each decade increase in bandwidth.

100 kHz to 26.5 GHz amplification
For preamplification in a one slot module, the HP 70620B Option 001 covers frequencies from 100 kHz to 26.5 GHz.

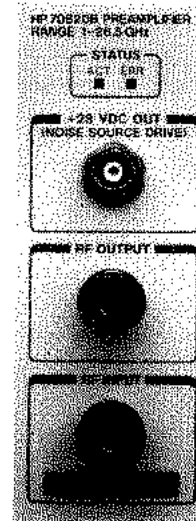
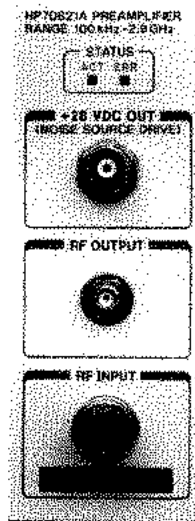

Noise figure measurements
The preamplifiers provide a drive signal for an excess noise source, allowing you to measure the noise figure of amplifiers and other devices. Calibrated noise sources such as the HP 346A/B/C can be turned on and off with a keystroke for easy noise figure measurements using the Y-factor technique.

Gain and flatness calibration
Using these preamplifiers is easy. Install either into your modular spectrum analyzer mainframe and the system is ready to use. The preamplifiers automatically calibrate the display of the analyzer, correcting for

preamplifier gain and flatness. All hard copy output and data storage, whether internal, on disk, or on memory card, have the corrected information.

Bypass mode or preamplifier mode
With a preamplifier installed in your mainframe, you can measure high or low level signals using the same RF input port. Built-in mechanical switches allow you to switch the preamplifier in and out of the signal path. One key press activates the bypass mode while maintaining amplitude calibration.

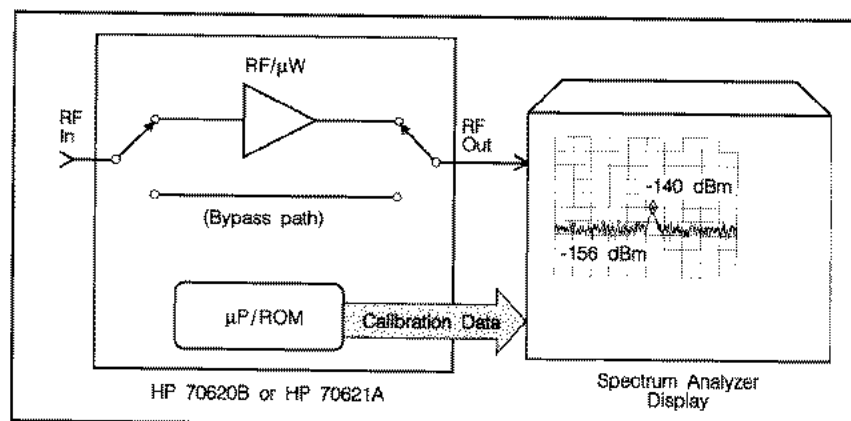

Modular preamplifier block diagram

Spectrum Analyzers

Preamplifiers

HP 70620B/70621A

Specifications

Specifications describe the instruments warranted performance over the 0° C to +55° C temperature range. **Characteristics** provide information about non-warranted instrument performance. Nominal values indicate the expected value of the parameter. All specifications apply after the instrument's temperature has been stabilized after one-hour warm-up, self-calibration routines have been run, and the preselector peak function has been executed. The preamplifier can be in the signal path or bypassed. The specifications indicate "preamp" when the preamplifier is in the signal path (PREAMP ON) and indicate "bypass" when the through-path is used (PREAMP OFF).

HP 70620B			
Frequency			
Frequency range	1.0–26.5 GHz		
	100 kHz–26.5 GHz (Option 001)		
Amplitude			
Maximum safe input power	+20 dBm		
Maximum dc input	±20 V		
	±10 V dc (Option 001)		
Gain Compression			
Preamplifier limited	< 1 dB for signals ≤ +7 dBm at the preamp output (characteristic) < 1 dB for signals ≤ +0 dBm at the preamp output (Option 001, 100 kHz–2.9 GHz, characteristic)		
Spectrum analyzer limited	< 0.5 dB for signal ≤ -10 dBm at the first mixer		
Displayed average noise level (DANL) (0 dB input atten, 10 Hz Res BW)			
		DANL (dBm)	
	Band	Preamp	Bypass
with the HP 71210C	1.0–2.9 GHz	-155	-138
	2.7–12.8 GHz	-153	-132
	12.6–22.0 GHz	-150	-130
with the HP 71210C and the HP 70620B Option 001	10 MHz–2.9 GHz	-156	-138
	2.7–12.8 GHz	-153	-132
with the HP 71200C Option 002 or 003 (preselected)	(characteristic, preamplifier placed before preselector)		
	1.0–2.9 GHz	-142	-119
	2.7–6.2 GHz	-142	-118
	6.0–12.7 GHz	-135	-109
	12.5–19.9 GHz	-126	-100
	19.7–22.0 GHz	-120	-94
	22.0–26.5 GHz (Option 003)	-119	-93
	(characteristic, preamplifier placed before preselector)		
with the HP 71200C Option 002 or 003 (preselected) and the HP 70620B Option 001	10 MHz–2.9 GHz	-140	-119
	2.7–6.2 GHz	-141	-118
	6.0–12.7 GHz	-134	-109
	12.5–19.9 GHz	-125	-100
	19.7–22.0 GHz	-119	-94
	22.0–26.5 GHz (Option 003)	-115	-93

HP 70620B cont.			
Bypass insertion loss	Band	(dB, characteristic)	
	0 Hz–2.9 GHz	≤ 1.0	
	2.7–12.7 GHz	≤ 1.8	
	12.7–26.5 GHz	≤ 2.5	
Preamplifier gain	Band	(dB, characteristic)	
	Standard	1.0–12.7 GHz	≥ 26
		12.7–26.5 GHz	≥ 24
	Option 001	1.0–26.5 GHz	28 dB (nominal)
		100 kHz–2.9 GHz	≥ 22
		2.7–12.7 GHz	≥ 25
12.7–22.0 GHz		≥ 23	
	22.0–26.5 GHz	≥ 20	
	100 kHz–26.5 GHz	28 dB (nominal)	
Preamplifier noise figure	Band	(dB, characteristic)	
	Standard	1.0–12.7 GHz	≤ 9.0
		12.7–22.0 GHz	≤ 13.0
		22.0–26.5 GHz	≤ 15.0
	Option 001	100 kHz–2.9 GHz	≤ 7.5
		2.7–12.7 GHz	≤ 9.5
12.7–22.0 GHz		≤ 14.0	
	22.0–26.5 GHz	≤ 16.0	
Third-order intercept	Standard	+15 dBm at preamp output (preamp characteristic)	
	Option 001	Band	TOI (preamp characteristic)
		100 kHz–2.9 GHz	0 dBm
	2.7–26.5 GHz	+15 dBm	
Second harmonic intercept	+30 dBm at the preamplifier output (preamplifier characteristic)		
Preamplifier frequency response	(characteristic; included in system frequency response)		
	Band	Variation (±dB)	
Peak variation		Preamp	Bypass
	1 GHz–12.7 GHz	1.0	0.8
Option 001	1 GHz–26.5 GHz	2.2	1.3
	100 kHz–2.9 GHz	1.2	0.8
	2.7–12.7 GHz	1.2	0.8
	2.7–22.0 GHz	1.9	1.3
	100 kHz–26.5 GHz	2.5	1.3

Spectrum Analyzers

Preamplifiers

HP 70620B/70621A

HP 70620B cont.

Second harmonic intercept	+30 dBm at the preamplifier output (preamplifier characteristic)		
System frequency response	(10 dB attn)		
	<i>Band</i>	<i>Variation (\pm dB)</i>	
		<i>Preamp</i>	<i>Bypass</i>
		(20-30° C)	(0-55° C)
with the HP 71210C peak variation			
	100 Hz-100 kHz (Option 001, char)	—	2.3
	100 Hz-1 GHz	—	2.3
	100 kHz-2.9 GHz (Option 001)	2.0	2.3
	1.0-2.9 GHz	2.0	2.3
	2.7-12.8 GHz	2.5	2.8
	12.6-22.0 GHz	3.0	3.0
Referenced to calibration signal			
	100 Hz-100 kHz	—	2.5
	100 Hz-1 GHz (Option 001)	—	2.5
	100 kHz-2.9 GHz (Option 001)	2.3	2.5
	1.0-2.9 GHz	2.3	2.5
	2.7-12.8 GHz	3.2	3.5
	12.6-22.0 GHz	3.5	3.6
with the HP 71200C Option 002 or 003 (preselected) peak variation			
	50 kHz-100 kHz (Option 001, char)	—	2.0
	50 kHz-1 GHz	—	2.0
	100 kHz-2.9 GHz (Option 001)	2.0	2.0
	1.0-2.9 GHz (char)	2.0	2.0
	2.7-6.2 GHz	2.4	2.2
	6.0-12.7 GHz	2.8	2.6
	12.5-19.9 GHz	4.0	3.7
	19.7-22.0 GHz	4.4	4.0
	22.0-26.5 GHz (Option 003)	4.7	4.0
Referenced to calibration signal			
	50 kHz-100 kHz (Option 001, char)	—	2.2
	50 kHz-1 GHz	—	2.2
	100 kHz-2.9 GHz (Option 001)	2.4	2.2
	1.0-2.9 GHz (char)	2.4	2.2
	2.7-6.2 GHz	3.5	3.4
	6.0-12.7 GHz	4.0	3.9
	12.5-19.9 GHz	5.2	5.0
	19.7-22.0 GHz	5.5	5.4
	22.0-26.5 GHz (Option 003)	5.8	5.4

HP 70620B cont.

Preamplifier frequency response	(characteristic, included in system frequency response)		
	<i>Band</i>	<i>Variation (\pm dB)</i>	
		<i>Preamp</i>	<i>Bypass</i>
Peak variation	1 GHz-12.7 GHz	1.0	0.8
	1 GHz-26.5 GHz	2.2	1.3
Option 001	100 kHz-2.9 GHz	1.2	0.8
	2.7-12.7 GHz	1.2	0.8
	2.7-22.0 GHz	1.9	1.3
	100 kHz-26.5 GHz	2.5	1.3
Amplitude temperature drift			
	<i>Band</i>	<i>dB/° C, char</i>	
Option 001	1-26.5 GHz	≤ -0.12	
	10 MHz-2.9 GHz	≤ -0.025	
	2.7-22.0 GHz	≤ -0.12	

Inputs/outputs

RF input/output	APC-3.5 (m), 50 Ω (nominal)		
Input VSWR	<i>Band</i>	<i>VSWR (char)</i>	
		<i>Preamp</i>	<i>Bypass</i>
Standard	1.0-2.7 GHz	2.2:1	1.3:1
	2.7-12.7 GHz	1.6:1	1.7:1
	12.7-26.5 GHz	2.8:1	2.4:1
Option 001	100 kHz-2.9 GHz	2.4:1	1.3:1
	2.7-12.7 GHz	2.2:1	1.7:1
	12.7-26.5 GHz	3.0:1	2.4:1
Output VSWR	<i>Band</i>	<i>VSWR (char)</i>	
		<i>Preamp</i>	<i>Bypass</i>
Standard	1.0-2.7 GHz	2.0:1	1.3:1
	2.7-12.7 GHz	2.0:1	1.5:1
	12.7-26.5 GHz	2.2:1	2.2:1
Option 001	100 kHz-2.9 GHz	2.4:1	1.3:1
	2.7-12.7 GHz	2.2:1	1.7:1
	12.7-26.5 GHz	3.0:1	2.4:1
Excess noise source drive	+28 Vdc out (used to drive HP 346A/B/C excess noise source) BNC (f)		
Reverse isolation standard	> 75 dB reduction in spectrum analyzer local oscillator emissions (characteristic)		
	<i>Band</i>	<i>Isolation (char)</i>	
Option 001	100 kHz-2.9 GHz	> 50 dB	
	2.7-26.5 GHz	> 75 dB	

Front panel connections

The preamplifier output is connected to the spectrum analyzer RF input with a semi-rigid cable supplied with the preamplifier. There are no rear-panel connections.

General

Calibration interval	3 years (recommended)
Standard weight	1.8 kg (4 lb) (nominal)
Option 001	2.5 kg (5.5 lb) (nominal)
Dimensions	1-slot-wide module

Other general specifications are given with the HP 70001A mainframe or the HP 70004A display/mainframe. Benefits of using the HP 70620B preamplifier with the HP 70301A may be limited by the tracking generator feed through.

Spectrum Analyzers

Preamplifiers

HP 70620B/70621A

HP 70621A			
Frequency			
Frequency range	100 kHz–2.9 GHz		
Amplitude			
Maximum safe input power	+20 dBm		
Maximum dc input	±20 V dc		
Gain compression			
Preamplifier limited	< 1 dB for signals ≤ 0 dBm at the preamp output (characteristic)		
Spectrum analyzer limited	< 0.5 dB for signals ≤ -10 dBm at the first mixer		
Displayed average noise level (DANL)			
		(0 dB atten, 10 Hz res BW)	
		<i>DANL (dBm)</i>	
	<i>Band</i>	<i>Preamp</i>	<i>Bypass</i>
with the HP 71100A/C	10 MHz–2.0 GHz	-156	-133
	2.0–2.9 GHz	-156	-130
with the HP 71200A/C (characteristic)	10 MHz–2.9 GHz (no preselector)	-150	
	10 MHz–2.9 GHz (preselected, Option 002 or Option 003)	-140	
with the HP 71210A/C (characteristic)	10 MHz–2.9 GHz	-155	
Bypass insertion loss			
	<i>Band</i>	<i>(dB, characteristic)</i>	
	0 Hz–2.9 GHz	≤ 1	
	0 Hz–26.5 GHz	≤ 6	
Preamplifier gain			
	≥ 24 dB (characteristic)		
	26 dB (nominal)		
Preamplifier noise figure			
	< 6 dB (characteristic)		
Third-order intercept			
	+0 dBm at preamp output (characteristic)		
Second harmonic intercept			
	+30 dBm at preamp output (characteristic)		

HP 70621A cont.			
System frequency response			
with the HP 71100C	(10 dB analyzer atten)		
	<i>Band</i>	<i>Variation (±dB)</i>	
		<i>Preamp</i>	<i>Bypass</i>
Peak variation	100 Hz–100 kHz	—	1.4
	100 kHz–2.5 GHz	1.8	1.4
	100 kHz–2.9 GHz	2.1	1.8
Referenced to a calibration signal	100 Hz–100 kHz	—	1.6
	100 kHz–2.5 GHz	2.0	1.6
	100 kHz–2.9 GHz	2.5	2.3
Preamplifier frequency response			
	(characteristic, included in system frequency response)		
	<i>Band</i>	<i>Preamp</i>	<i>Bypass</i>
	100 kHz–2.9 GHz	± 1.2 dB	—
	0 Hz–2.9 GHz	—	± 0.8 dB
Amplitude temperature drift			
	≤ -0.025 dB/° C (characteristic)		
Inputs/outputs			
RF input	Type-N (f), 50 Ω (nominal)		
RF output	SMA (f), 50 Ω (nominal)		
	<i>Preamp (char)</i>	<i>Bypass (char)</i>	
Input VSWR	2.0:1	1.3:1	
Output VSWR	1.9:1	1.3:1	
Excess noise source drive	+28 V dc out (used to drive HP 346A/B/C excess noise source), BNC (f)		
Reverse isolation	> 50 dB reduction in spectrum analyzer local oscillator emissions (characteristic)		
Front panel connections			
The preamplifier output is connected to the spectrum analyzer RF input with a semi-rigid cable supplied with the preamplifier. There are no rear-panel connections.			
General			
Calibration interval	3 years (recommended)		
Weight	1.8 kg (4 lb) nominal		
Dimensions	1-slot-wide module		

Spectrum Analyzers

Preamplifiers

HP 70620B/70621A

Ordering Information

HP 70621A 100 kHz–2.9 GHz preamplifier

Option 098 HP 70900A controller board upgrade kit

Required only if this module is being added to an existing system with HP 70900A local oscillator ROM versions 850730 or 860203*

Option 099 firmware upgrade kit

Required only if this module is being added to an existing system with HP 70900A/B local oscillator ROM versions between 861015 and 900314*

Option 910 extra installation and verification manual

Option 915 service manual, including operation verification software

HP 70620B 1–26.5 GHz preamplifier

Option 001 100 kHz–26.5 GHz

Extended RF frequency range to 100 kHz from 1 GHz

Option 098 HP 70900A controller board upgrade kit

Required only if this module is being added to an existing system with HP 70900A local oscillator ROM versions 850730 or 860203*

Option 099 firmware upgrade kit

Required only if this module is being added to an existing system with HP 70900A/B local oscillator ROM versions between 861015 and 900314*

Option 910 extra installation and verification manual

Option 915 service manual, including operation verification software

* The ROM version is the firmware date code (YYMMDD, Y = year, M = month, D = day). Press the MENU hard key, then soft keys CONFIG (or MISC, SERVICE) and ROM VERSION on your analyzer.

Spectrum Analyzers

Noise-Figure Measurement Personality

HP 70875A

Faster, easier, calibrated noise figure and gain measurements

Swept noise figure and gain from 10 MHz to 26.5 GHz

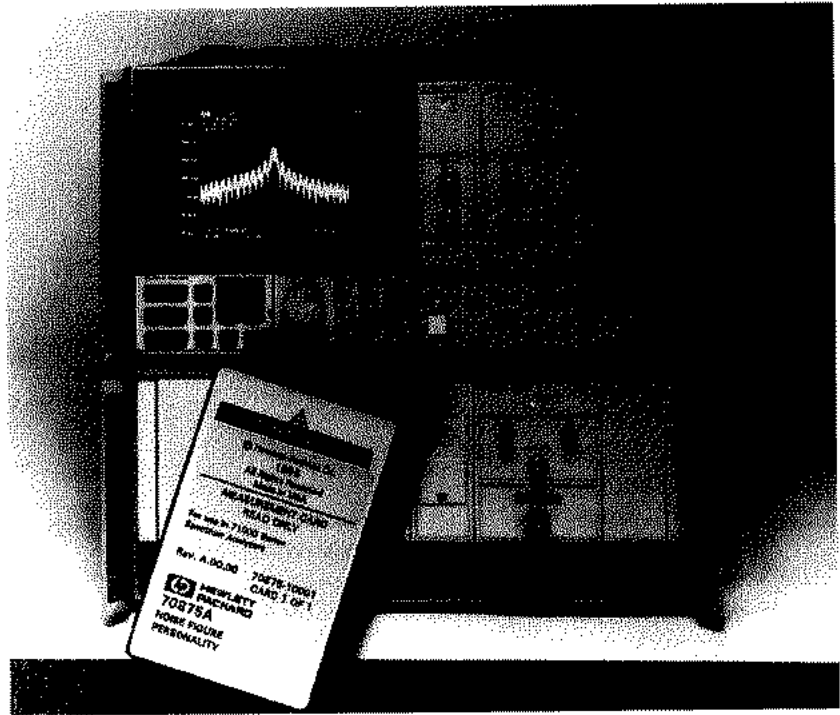

The HP 70875A noise-figure measurement personality software adds noise-figure measurement capability to the HP 71000 series MMS spectrum analyzers. Combined with an HP 346A or 346C noise source and an HP 70620B preamplifier module, this measurement personality provides displayed swept noise-figure and gain measurements from 10 MHz to 26.5 GHz.

Measurements are fully programmable, so an MMS spectrum analyzer with the noise-figure measurement personality is a natural fit for aerospace, defense, and communication ATE measurement systems.

Key features

In addition to swept noise figure and gain measurements, this spectrum analyzer personality offers test capability for fast results; noise-figure and spectrum-analyzer mode-switching for stray signal detection; and selectable measurement bandwidths to directly measure narrowband devices such as IF/receiver systems. In addition, the measurement personality incorporates many features of the HP 71000 series MMS spectrum analyzers, including save/recall functions and memory card reader for storage of excess noise ratio (ENR) data tables and limit-line tables.

With its menu-driven interface and marker functions, the HP 70875A simplifies microwave noise-figure measurements. Marker functions make it easy to read noise figure and gain for the entire sweep. The friendly user interface is fully compatible with systems using the HP 70207B PC-based display option.

Spectrum Analyzers

Noise-Figure Measurement Personality

HP 70875A

Specifications

	<i>Performance limits</i>	<i>Conditions</i>
Noise figure measurement		
Range	0 to +30 dB	
Resolution	0.01 dB	
Instrument uncertainty	± 0.5 dB	10 MHz to 2.9 GHz, measurement bandwidth=3 MHz
	± 0.6 dB	2.9 to 26.5 GHz, measurement bandwidth=3 MHz
Gain measurement		
Range	0 to +30 dB	
Resolution	0.01 dB	
Instrument uncertainty	± 0.5 dB	10 MHz to 2.9 GHz, measurement bandwidth=3 MHz
	± 0.6 dB	2.9 to 26.5 GHz, measurement bandwidth=3 MHz
Input		
Frequency range	10 MHz to 22 GHz	Using HP 70908A RF section
	10 MHz to 26.5 GHz	Using HP 70909A or 70910A RF section
System noise figure	< 11 dB	10 MHz to 2.9 GHz
	< 12 dB	2.9 to 12.8 GHz
	< 18 dB	12.8 to 22.0 GHz
	< 21 dB	22.0 to 26.5 GHz
Input SWR	< 2.4:1	10 MHz to 2.9 GHz
	< 2.2:1	2.9 to 12.8 GHz
	< 3.0:1	12.8 to 26.5 GHz
IF processing		
IF bandwidths	1 kHz to 3 MHz	In 10% increments
Noise averaging	20 ms to 1000 s	

Ordering Information

HP 70875A noise figure measurement personality (includes memory card, 3.5-inch disk for P model analyzers, and user's guide)

Configuration requirements

HP 71100C/P, 71209A/P, 71210C/P, or 71910A/P spectrum analyzer

HP 70620B Option 001 preamplifier

HP 346B or 346C noise source

Spectrum Analyzers

Tracking Generator Systems

HP 70300A/70301A/70871A

Scalar analysis for component testing

*Tracking generators
100 Hz to 18 GHz*

*> 130 dB dynamic range
@ 18 GHz*

Scalar software personality

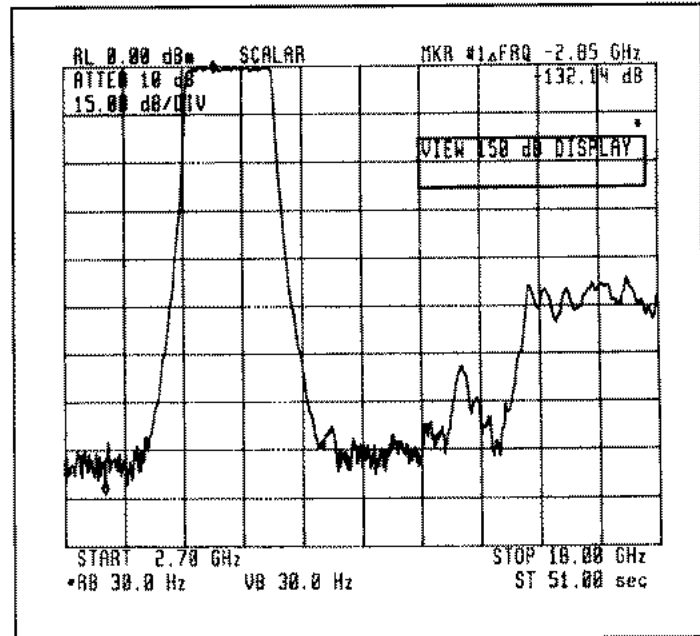

Measure filter rejection with 130 dB dynamic range at 18 GHz (150 dB display format using scalar personality).

An HP 70000 component test system makes component and sub-assembly testing faster and more precise. Three high-performance systems are available based on the HP 71100C/P, 71200C/P, 71209A/P, and 71210C/P spectrum analyzers.

Configure a general-purpose component test workstation that provides scalar and signal analysis measurement capabilities. Just add a combination of tracking generators, synthesizers, and power meters.

System sensitivity reaches -134 dBm at 22 GHz or -154 dBm with the modular preamplifier. This lets you detect extremely low level spurious signals. Add a synthesizer to measure non-linear device characteristics such as harmonic and intermodulation distortion.

High dynamic range

By adding a tracking generator, you get stimulus-response capability to measure gain, frequency response, isolation, and return loss. For demanding filter rejection measurements, combine an HP 70301A microwave tracking generator with the HP 71210C/P spectrum analyzer. This gives you a scalar dynamic range of greater than 130 dB from 2.7 to 18 GHz.

The system has very high selectivity, with resolution bandwidths as narrow as 10 Hz. High selectivity allows measurements in the presence of other signals—a key advantage when measuring LO-to-RF isolation of a mixer or the return loss of an active antenna system. Critical switch-isolation measurements require very high dynamic range, often more than 90 dB. Unlike a point-by-point measurement system, the HP 70000 scalar system sweeps quickly and provides continuous data. So, you can quickly characterize switch isolation.

Spectrum Analyzers

Tracking Generator Systems

HP 70300A/70301A/70871A

Performance and personality

Exceptional performance capabilities do not have to be complicated. The HP 70871A scalar personality adds automatic measurement routines for component testing and can be ordered with the HP 70000 system. This personality orchestrates the test process and guides you through the measurement. Testing becomes faster and easier using the signal mode and scalar mode included in the personality.

Signal mode

The signal mode portion of the personality includes spur-search and harmonic-distortion routines. Spur search lets you enter measurement parameters and lists the frequency and amplitude of any spurious signal that meets your specified criteria. The harmonic-distortion routine measures the fundamental and its second and third harmonics. It also calculates the harmonic-distortion percentage—all with a single keystroke.

Scalar mode

The scalar-mode portion of the personality provides a dedicated scalar-analyzer interface and high-level routines to simplify your stimulus-response measurements. You can measure gain or loss, device bandwidth, rejection, and return-loss. To ensure accurate measurements, the scalar mode leads you through the proper calibration sequences. Sequences for transmission thru calibration and a reflection open/short calibration are included.

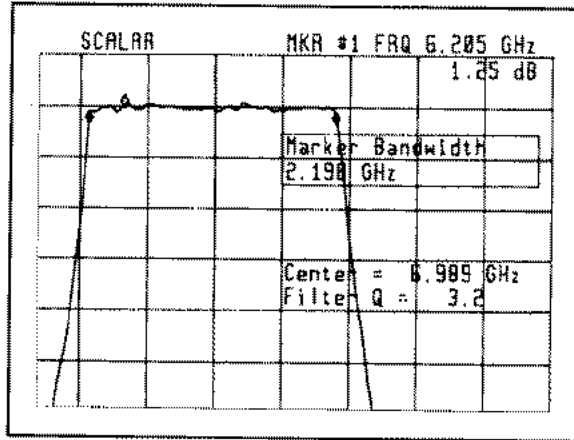

Filter 3 dB bandwidth and Q

To simplify filter characterization, high level test routines measure 3 dB bandwidth, Q, and shape factor—at a single keystroke. Limit lines improve productivity by providing a simple PASS or FAIL message when a device is tested for specified criteria. Flat, sloped, or point limit lines provide maximum flexibility. Limit lines can be saved in internal memory, disk, or memory card. Use the golden device function to establish a continuous pass/fail tolerance band based on a production device, an especially useful feature for making real-time adjustments.

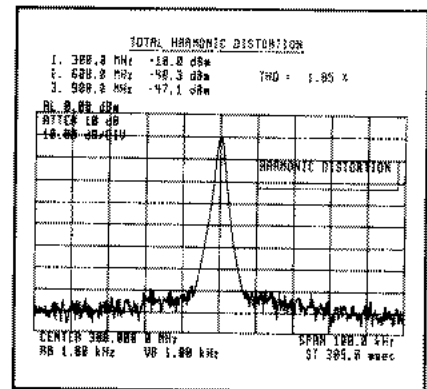

One-button harmonic distortion measurement

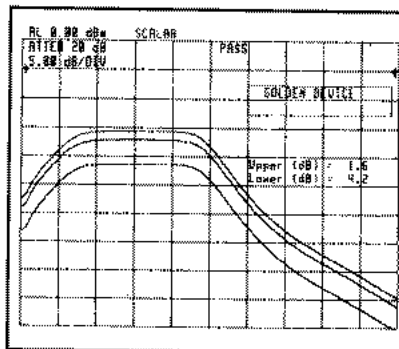

Golden Device function

Spectrum Analyzers

Tracking Generator Systems

HP 70300A/70301A/70871A

Specifications for HP 70300A and HP 70301A

Specifications describe warranted performance over the specified temperature range after the system temperatures have stabilized and self-calibration routines have run. Characteristics provide useful but non-warranted performance information in the form of nominal values.

	HP 70300A	HP 70301A
Frequency range	20 Hz–2.9 GHz	2.7–18 GHz
Frequency accuracy (≤ 10 MHz synthesized span)	± [(freq × ref ¹) + 1%span + 15 Hz]	± [(freq × ref ¹) + 1%span + 15 Hz]
Freq tracking drift	< 3 Hz/hr	< 3 Hz/hr
Tracking adjust range	± 500 Hz in 1 Hz steps	± 500 Hz in 1 Hz steps
Freq offset range	± 10 MHz w/ext 21.4 MHz	± 5 MHz w/ext 21.4 MHz
Maximum leveled power	-10 dBm	-2 dBm, (0 dBm 20–30° C)
Amplitude control range	0 to -91 dBm	+14.5 to -66 dBm
Vernier range	11 dB (0.01 dB resolution)	11 dB (0.1 dB resolution)
Power sweep range	0 to -10 dB	NA
Amplitude accuracy (20–30° C)		
Absolute	± 0.75 dB @ 300 MHz	± 0.5 dB @ 2.7 GHz
Flatness	± 0.5 dB	± 1.0 dB
Incremental	± 0.15 dB/dB, ±0.5 dB total	± 0.15 dB/dB, ± 0.8 dB total
Total absolute accuracy	± 1.75 dB	± 2.3 dB
Amplitude drift (characteristic)	< ± 0.05 dB/° C @ -10 dBm	< ± 0.05 dB/° C @ -2 dBm
Output attenuator range	70 dB in 10-dB steps	55 dB in 5-dB steps
Repeatability	≤ ± 0.2 dB for any setting	≤ ± 0.2 dB for any setting
Amplitude modulation		
Depth	0–100%	NA
Rate	20 Hz–20 kHz	NA
Spectral purity	@ -10 dBm	@ -2 dBm, 6 GHz
Noise sidebands (10 kHz)	< -105 dBc/Hz	< -90 dBc/Hz (characteristic)
Sidebands	< -60 dBc	< -70 dBc (characteristic)
Spurious (max leveled power)		
Harmonics	< -25 dBc (20 Hz–10 MHz) < -30 dBc (10 MHz–2.9 GHz)	2nd: < -7 dBc (< -15 dBc typ) 3rd: < -11 dBc (< -15 dBc typ)
Non-harmonic	< -30 dBc (20 Hz–2 GHz) < -20 dBc (2 GHz–2.9 GHz)	< -60 dBc
Sub-harmonic	none	none
RF off residuals	< -120 dBm tracking < -80 dBm non-tracking	< -120 dBm tracking < -65 dBm LO emissions
Temperature		
Operating	0 to 55° C	0 to 50° C
Storage	-40 to +75° C	-40 to +75° C
Weight	5.0 kg (11 lb)	6.9 kg (15.2 lb)
Height	127 mm (5.0 inch)	127 mm (5.0 inch)
Width	96 mm (3.8 inch)	144 mm (5.7 inch)
Length	467 mm (18.4 inch)	467 mm (18.4 inch)
EMI	Conducted and radiated interference is in compliance with CISPR publication 11 (1975) and FTZ 1046. Radiated interference is in compliance with MIL-STD 461B, part 7, RE02.	

¹ Freq reference accuracy: ± 1.3 × 10⁻⁹/yr standard, ± 5.0 × 10⁻¹⁰/day with HP 70310A.

Spectrum Analyzers

Tracking Generator Systems

HP 70300A/70301A/70871A

Input and output characteristics

All input/output ports are 50 Ω impedance with < 1.5:1 VSWR and with a maximum safe damage level (MSDL) of +20 dBm, 20 Vdc unless noted.

Front Panel	HP 70300A	HP 70301A
RF output	Type-N female. MSDL: +20 dBm, 0 Vdc in dc-coupled mode	Type-N female. MSDL: +20 dBm, 0 Vdc
VSWR	< 1.4:1 leveled (10 dB atten) < 3:1 unleveled (0 dB atten)	< 1.5:1 from 2.7–12.8 GHz, (5 dB atten) < 1.7:1 from 12.8–18 GHz, (5 dB atten) < 2:1 (0 dB atten)
Ext ALC input	BNC female. 10 k Ω Use with 0 to -100 mV negative detector.	BNC female. 1 M Ω Use with 0 to -100 mV negative detector.
AM input/output	BNC female. 600 Ω input Z Max input/output: 5 V peak	NA
Low band input	NA	SMA female. 10 MHz–2.9 GHz supplied from HP 70300A Insertion loss: < 4.0 dB
Rear Panel (Applies to HP 70300A and HP 70301A.) All connectors are SMB male, 50 Ω impedance, unless otherwise noted.		
LO in, 3–6.6 GHz	SMA female, +0.5 to +18.0 dBm required. < 2:1 VSWR. MSDL: +20 dBm, 5 Vdc	
LO out, 3–6.6 GHz (HP 70301A only)	SMA female, +6.0 to +14.0 dBm, < 3:1 VSWR. MSDL: +20 dBm, 5 Vdc	
21.4 MHz in/out (HP 70301A)	For modulation or offset input, < +5 dBm input level (HP 70300A)	
2 \pm 2 dBm input level		
300 MHz in	300 \pm 0.03 MHz. Input level: +2 to -2 dBm	
300 MHz out	0 \pm 1 dBm. < -30 dBc harmonics (HP 70300A), < -25 dBc harmonics (HP 70301A)	
3.6214 MHz in (HP 70300A Opt. H01)	SMA female. For modulation or offset input (\pm 60 MHz typ, < -15 dBm input level), < 3:1 VSWR	
3.6214 MHz out (HP 70300A Opt. H01)	SMA female, -10 to -30 dBm, < 3:1 VSWR. MSDL: +20 dBm, 40 Vdc	
Tune + span in	4.5–10.2 Vdc required. 1.5 V/GHz control voltage. > 100 k Ω .	
HSWP in (HP 70300A)	Sweep ramp trigger line from HP 70900A/B; TTL	
Sweep in (HP 70300A)	Sweep ramp from HP 70900A/B.	

System Specifications	HP 71100C/P	HP 71200C/P	HP 71209A/P	HP 71210C/P
	RF system			
Signal freq range	100 Hz–2.9 GHz	50 kHz–22 GHz	50 kHz–26.5 GHz	100 Hz–22 GHz
Scalar freq range (HP 70300A)	100 Hz–2.9 GHz	50 kHz–2.9 GHz	50 kHz–2.9 GHz	100 Hz–2.9 GHz
with HP70301A	NA	2.7–18 GHz	2.7–18 GHz	2.7–18 GHz
Vector freq range				
HP 85081A HI-Z input	100 kHz–1 GHz	100 kHz–1 GHz	100 kHz–1 GHz	100 kHz–1 GHz
HP 85082A 50 Ω	300 kHz–2 GHz	300 kHz–2 GHz	300 kHz–2 GHz	300 kHz–2 GHz
Scalar dynamic range				
@ 2.0 GHz	>124 dB	>119 dB	>128 dB	>128 dB
@ 10 GHz	NA	>50 dB typ ¹	>130 dB	>130 dB
@ 18 GHz	NA	>50 dB typ ¹	>130 dB	>130 dB
Dynamic accuracy²	\pm 0.5 dB	\pm 0.5 dB	\pm 0.5 dB	
Tracking generator feedthrough (dBm in 10 Hz BW)				
@ 2 GHz	< -134 dBm	< -129 dBm	< 138 dBm	< 138 dBm
@ 10 GHz	NA	< -50 dBm	< 130 dBm	< 130 dBm
@ 18 GHz	NA	< -50 dBm	< 130 dBm	< 130 dBm

¹ Dynamic range limited by LO emission. Up to 120 dB @ 18 GHz for isolation measurement only.

² Dynamic accuracy is the calibrated amplitude accuracy of the system over 90 dB range.

Spectrum Analyzers

Tracking Generator Systems

HP 70300A/70301A/70871A

Ordering Information

Three typical component test workstations are configured below. For complete system ordering information, please see HP 71000 Modular Measurement System Ordering and Configuration Guide (literature number 5954-2700).

Modules

HP 70300A tracking generator

- Option 098 CPU and RAM/ROM upgrade
- Option 099 RAM/ROM upgrade
- Option 1BN certificate of calibration
- Option 1BP certificate of calibration and data
- Option 871 scalar personality
- Option 910 extra user's manual
- Option 915 service manual set

HP 70301A tracking generator

- Option 001 delete 55 dB input attenuator
- Option 098 CPU and RAM/ROM upgrade
- Option 099 RAM/ROM upgrade
- Option 1BN certificate of calibration
- Option 1BP certificate of calibration and data
- Option 871 scalar personality
- Option 910 extra user's manual
- Option 915 service manual set

Systems

RF system

- HP 71100C/P RF spectrum analyzer
- HP 70300A RF tracking generator
- HP 70871A scalar personality kit

Mid-performance microwave system

- HP 71200C/P microwave spectrum analyzer
- HP 70301A microwave tracking generator
- HP 70871A scalar personality kit

High-performance microwave systems

- HP 71209A/P microwave spectrum analyzer or
HP 71210C/P high-sensitivity microwave spectrum analyzer
- HP 70301A microwave tracking generator
- HP 70300A RF tracking generator
- HP 70100A power meter
- HP 70871A scalar personality kit

HP 70871A scalar personality kit

(includes signal mode)

For use with HP 70300A or HP 70301A. Requires HP 70900A/B firmware rev. 880901 or later

HP 70900A upgrade kits (compatible with HP 70900A or HP 70900B local oscillator)

- HP 70860A high-speed controller board upgrade kit
- HP 70861A RAM/ROM upgrade kit

Spectrum Analyzers

Millimeter Spectrum Analysis

HP 11974, 11970, and 70907

HP 11974 series preselected millimeter mixers to 75 GHz

HP 11970 series millimeter mixers to 110 GHz (unpreselected)

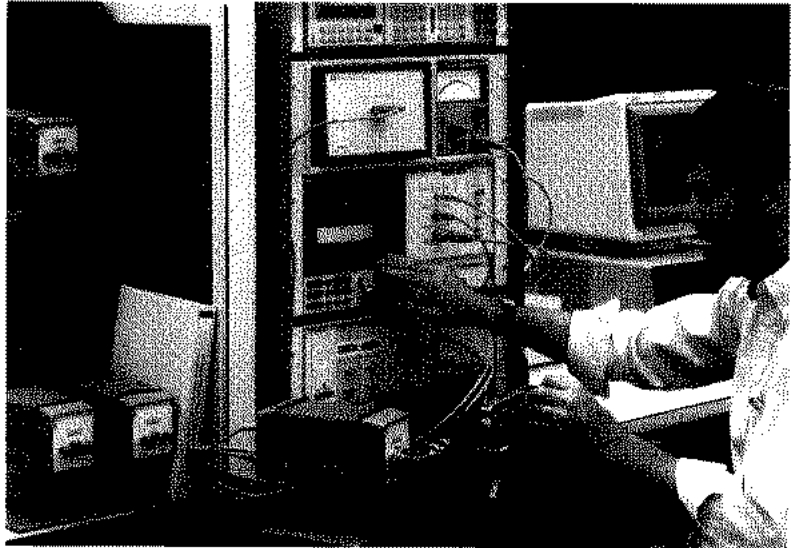

Millimeter frequencies are easily analyzed by MMS spectrum analyzers using either the HP 11974 series preselected mixers or the unpreselected HP 11970 series. The HP 71209A/P system directly supports a single external mixer. To connect additional mixers, or to use with other MMS spectrum analyzer systems, the HP 70907B external mixer interface module (EMIM) is required.

The HP 11974 mixers make preselected signal analysis available to 75 GHz for broadband signal analysis, general spurious measurements, component test, and signal surveillance.

Benefits of the preselected millimeter configuration include reduced overload from many signals and greater dynamic range. The system is easy to use because you no longer need to use complicated signal identification techniques. Anyone familiar with preselected microwave spectrum analyzers can quickly and easily make millimeter measurements.

Figure 1 shows how true signals can be obscured by displayed multiple and images in an unpreselected system, compared to the ease of identifying true signals in a preselected system. Both photos are of the same 5 GHz comb signal.

Working above 75 GHz

For analysis above 75 GHz, the HP 11970 series mixers provide operation to 110 GHz. Above 110 GHz, other manufacturers provide mixers to 325 GHz. Any of these may be used with the HP 71209A/P system, or by using the HP 70907B EMIM. None of these mixers are preselected.

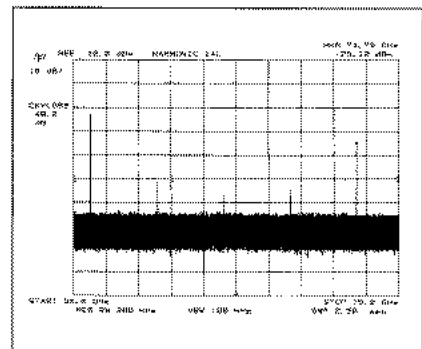

(a)

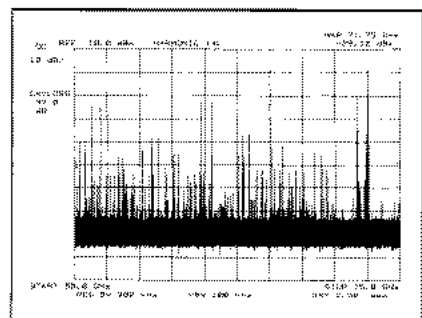

(b)

Figure 1. Preselected (a) and unpreselected (b) sweeps

Spectrum Analyzers

Millimeter Spectrum Analysis

HP 11974, 11970, and 70907



Amplitude calibration

Each HP 11974 and 11970 mixer is characterized for conversion loss versus frequency. Just enter the conversion loss data into your HP MMS spectrum analyzer and then make amplitude-calibrated measurements.

System configuration

The MMS spectrum analyzer provides the HP 11974 mixers with a swept LO signal and a tune and span signal. The HP 11974 mixers return an IF signal to the spectrum analyzer for normal IF processing that is equivalent to the internal spectrum analyzer modes. The HP 11974 series include a standalone power supply. See the HP 11974 data sheet (literature number 5952-2748) for more complete information.

HP 11970 series mixers (unpreselected)

Specifications

System¹

Affected when an RF section is replaced by the HP 70907B

Frequency range	Tunable in 1 Hz increments
Used with HP 11970 mixers	18 to 110 GHz
Used with HP 11974 mixers	26.5 to 75 GHz
Other manufacturers' mixers	2.7 to 325 GHz

Maximum safe input power (AC average continuous power)

Used with HP 11970 mixers	+20 dBm
Used with HP 11974 mixers	+25 dBm

Pulse power

Used with HP 11970 mixers	+250 μ W peak power with <1 μ s pulse (+20 dBm average power)
---------------------------	---

Displayed average noise level 10 Hz resolution BW, 0 dB attenuation

Used with HP 11970 mixers

18 to 26.5 GHz	<-118 dBm
26 to 40 GHz	<-116 dBm
33 to 50 GHz	<-114 dBm
40 to 60 GHz	<-114 dBm
50 to 75 GHz	<-112 dBm
75 to 110 GHz	<-105 dBm

Used with HP 11974 mixers

26 to 40 GHz	<-111 dBm
33 to 50 GHz	<-106 dBm
40 to 60 GHz	<-109 dBm
50 to 75 GHz	<-94 dBm

1 dB gain compression RF input for 1 dB increase in conversion loss

Used with HP 11970 mixers <1 dB gain compression level (specification)

18 to 26.5 GHz	<-3 dBm
26 to 40 GHz	<-5 dBm
33 to 50 GHz	<-7 dBm
40 to 60 GHz	<-7 dBm
50 to 75 GHz	<-3 dBm
75 to 110 GHz	<-1 dBm

Used with HP 11974 mixers

(characteristic)	dBm minimum
26 to 40 GHz	+5 dBm
33 to 50 GHz	0 dBm
40 to 60 GHz	0 dBm
50 to 75 GHz	+3 dBm

¹ More detailed specifications are given in the HP 70900B Installation and Verification manual.

Spectrum Analyzers

Millimeter Spectrum Analysis

HP 11974, 11970, and 70907

Specifications cont.

Image responses	(Signals displayed 6 MHz and 42.8 MHz from the applied signal frequency)	
<i>Used with HP 11970 mixers</i>	<-80 dBc	
<i>Used with HP 11974 mixers</i>	<-80 dBc	
Image rejection	(Signals displayed at $2xf_{if}$ above applied signal frequency)	
<i>Used with HP 11970 mixers²</i>		
<i>Used with HP 11974 mixers</i>	<i>0 to 55° C</i>	<i>20 to 30° C</i>
<input type="checkbox"/> 26.5 to 40 GHz (n=8)	-54 dBc max	-59 dBc max
<input type="checkbox"/> 33 to 50 GHz (n=10)	-50 dBc max	-55 dBc max
<input type="checkbox"/> 40 to 60 GHz (n=10)	-50 dBc max	-55 dBc max
<input type="checkbox"/> 50 to 67 GHz (n=14)	-50 dBc max	-55 dBc max
<input type="checkbox"/> 67 to 75 GHz (n=14)	-40 dBc max	-45 dBc max
Multiple responses	(due to in-range applied signals mixing with LO harmonics other than order n)	
<i>Used with HP 11970 mixers²</i>		
<i>Used with HP 11974 mixers</i>		
<input type="checkbox"/> 26.5 to 40 GHz (n=8)	-63 dBc max	
<input type="checkbox"/> 33 to 50 GHz (n=10)	-60 dBc max	
<input type="checkbox"/> 40 to 60 GHz (n=10)	-60 dBc max	
<input type="checkbox"/> 50 to 67 GHz (n=14)	-60 dBc max	
<input type="checkbox"/> 67 to 75 GHz (n=14)	-55 dBc max	
Frequency response³	10 dB input attenuation	
<i>Used with HP 11970 mixers (specification)</i>		
<input type="checkbox"/> 18 to 26.5 GHz	± 2.3 dB	
<input type="checkbox"/> 26 to 40 GHz	± 2.3 dB	
<input type="checkbox"/> 33 to 50 GHz	± 2.3 dB	
<input type="checkbox"/> 40 to 60 GHz	± 2.3 dB	
<input type="checkbox"/> 50 to 75 GHz	± 2.5 dB	
<input type="checkbox"/> 75 to 110 GHz	± 3.5 dB	
<i>Used with HP 11974 mixers (characteristic)</i>	<i>0 to 55° C</i>	
<input type="checkbox"/> 26.5 to 40 GHz (n=8)	± 4.5 dB	
<input type="checkbox"/> 33 to 50 GHz (n=10)	± 4.0 dB	
<input type="checkbox"/> 40 to 60 GHz (n=10)	± 4.0 dB	
<input type="checkbox"/> 0 to 75 GHz (n=14)	± 4.0 dB	
Internal 321.4 MHz calibrator accuracy	± 0.6 dB at -35 dBm	

² Not specified or characterized using HP 11970 series mixers.

³ Uncorrected.

Ordering Information

HP 70907B external mixer interface module

Option 098 CPU and RAM/ROM upgrade

Option 099 RAM/ROM upgrade

Option 910 extra user manual

Option 915 service manual set

HP 11974 series preselected millimeter mixers

Series consists of

HP 11974A 26.5 to 40 GHz

HP 11974Q 33 to 50 GHz

HP 11974U 40 to 60 GHz

HP 11974V 50 to 75 GHz

Options (available for all HP 11974 series mixers)

Option 001 input isolator attached and included in calibration

Option 003 delete power supply

Option 910 extra manual

5062-3989 front handle kit for power supply

5062-3957 rack mount kit with extended flange for power supply (half-width)

HP 11970 series millimeter mixers

Series consists of

HP 11970K 18 to 26.5 GHz

HP 11970A 26.5 to 40 GHz

HP 11970Q 33 to 50 GHz

HP 11970U 40 to 60 GHz

HP 11970V 50 to 75 GHz

HP 11970W 75 to 110 GHz

Option 009 connection kit (available for all HP 11970 mixers)

Lightwave and Communications

Custom Engineering

CS-6200



*Extremely wide bandwidth—
1 GHz instantaneous*

*Very low group delay variation—
less than 10 ns*

*Low phase noise—less than
-100 dBc/Hz @ 10 kHz offset*

*Low spurious content—less than
-50 dBc at rated output levels*

*High tuning resolution—
4 Hz step size*

*Fully synthesized and phase
coherent throughout*

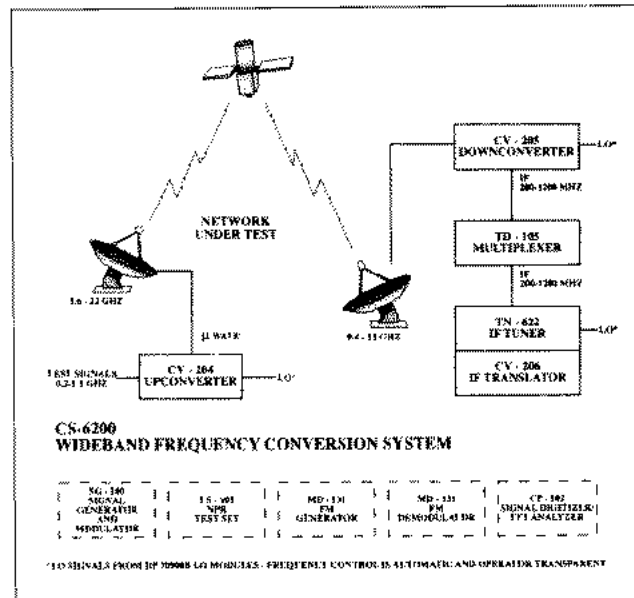

*Other products under development
for the CS-6200 System include:*

- SG-100 Test Signal Generator and Modulator
- TS-101 NPR Test Set
- MD-131 Wideband FM Generator
- MD-132 Wideband FM Demodulator
- CP-102 Signal Digitizer and FFT Analyzer

The CS-6200 Wideband Frequency Conversion System is an important tool in the test and measurement of microwave transmission and reception equipment. Through the use of this system, complex, high-speed test stimuli are upconverted to an appropriate microwave frequency and applied to the network to be tested. The output of the network under test is downconverted by the system back to the input frequency of the measurement device. Because each instrument which forms the system exhibits an extremely wide instantaneous bandwidth (up to 1 GHz), low local oscillator phase noise, and low spurious product distortion, excellent test signal quality is maintained. This results in precise, accurate, and repeatable measurements.

The system consists of five special plug-in modules which are used in conjunction with standard HP modular measurement system modules and displays. The CV-204 Upconverter combines with an HP 70310A precision frequency reference module, an HP 70900B LO module, and an HP 70004A display to translate test signals up to any part of the 1.6 to 22 GHz spectrum. The CV-205 Downconverter, the TD-105 Multiplexer, the TN-622 IF Tuner, and the CV-206 IF Translator, along with two HP LO modules, a precision frequency reference module, and an HP 70004A display convert the microwave test signals back down to the input frequency of the measurement device. The system is controlled by the use of the front panel soft keys and alphanumeric keypad on each HP 70004A display.

Lightwave and Communications

Custom Engineering

CS-6200

Specifications

CV-204 Upconverter

Input frequency range	200 to 1200 MHz
Output frequency range	1.6 to 22.0 GHz
Instantaneous bandwidth	1 GHz
Group delay variation	< 10 ns
Nominal output level	+10 dBm (+20 dBm, 1 dB gain compression)
Output attenuation range, 1 dB increments	101 dB
Low phase noise @ -100 dBc/Hz (10 kHz offset)	
Tuning step size	4 Hz
Input spectrum sense maintained at output	
3/8-width, 1-slot module	
Automatic tuning mode	Output frequency tracks spectrum analyzer center frequency

TN-622 IF Tuner

Input frequency range	0.1 to 2.9 GHz
Output frequency range	450 to 950 MHz
Instantaneous bandwidth	500 MHz
Group delay variation	< 10 ns
Nominal output level	-6 dBm (+20 dBm, 1 dB gain compression)
Low phase noise @ < -100 dBc/Hz (10 kHz offset)	
Tuning step size	2 Hz
Input spectrum sense maintained at output	
2/8-width, 2-slot module	
Automatic tuning mode	Input center frequency tracks spectrum analyzer center frequency

CV-206 IF Translator

Input center frequency	700 MHz
Simultaneous output signals centered at	20 MHz, 70 MHz, 100 MHz, 160 MHz
Wide output bandwidths	175% of output center frequency
Nominal output level	0 dBm (+20 dBm, 1 dB gain compression)
Low group delay variation	< 10 ns typical
Phase noise	< -100 dBc/Hz (10 kHz offset)
Input spectrum sense maintained at output	
3/8-width, 3-slot module	

Specifications

CV-205 Downconverter

Input frequency range	0.4 to 22 GHz
Output frequency range	200 to 1200 MHz
Instantaneous bandwidth	1 GHz
Group delay variation	< 10 ns
101 dB attenuation range optimizes signal operation level	
Output level	0 dBm (+20 dBm, 1 dB gain compression)
Phase noise	< -100 dBc/Hz (10 kHz offset)
Tuning increment	4 Hz
Input spectrum sense maintained at output	
Weather-tight NEMA Type 4 cabinet	
Remote operation at antenna site optimizes system performance	
AC or DC operation	

TD-105 Multiplexer

Input frequency range	200 to 1200 MHz
Six isolated output channels (200 to 1200 MHz)	
Output level	0 dBm (+20 dBm, 1 dB gain compression)
Input signals	Gain equalized
Provides remote control interface to CV-205 Downconverter	
2/8-width, 2-slot module	

For information about the CS-6200 Wideband Frequency Conversion System or any of the described instruments, please contact:

Condor Systems, Inc. (East)
45180 Business Court, Suite 200
Sterling, VA 20166

Phone: 703 709-8300
Fax: 703 709-8304

Lightwave and Communications

Digital Radio Analyzer

DRA-M150



Precise characterization of all system elements including the radio path

Operation at IF frequencies between 20 and 200 MHz

Fully programmable, variable delay, precision fade simulator with interference and noise generators, variable correlation coefficient

2D and 3D graphical analysis

Local data logging

Remote dial-up operation

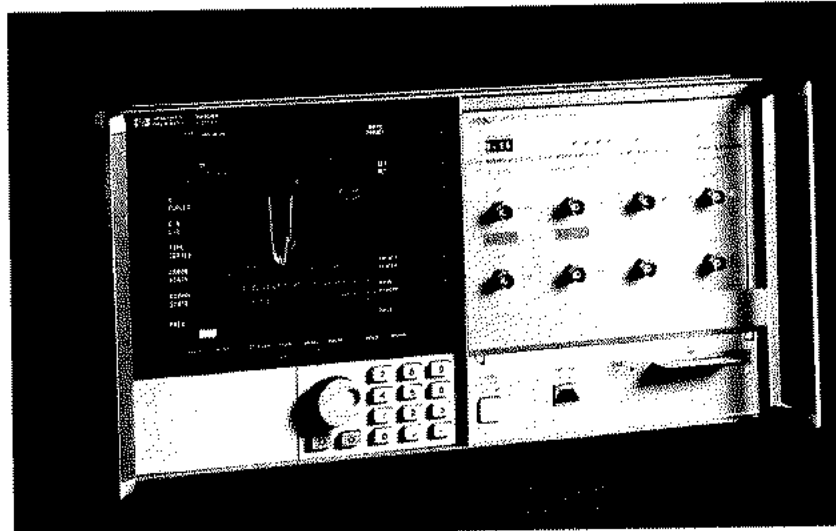

The Digital Radio Analyzer (DRA) has been designed as a tool to improve the productivity and performance of personnel and equipment involved in the development, evaluation, installation, and maintenance phases of high capacity digital microwave radio systems.

The DRA has many built-in features which enable it to be used as a test instrument for out-of-service and in-service measurements. It is designed to work with systems of 8 to 200 Mbit/s capacity in the radio bands between 2 and 12 GHz.

Integrated test instrument

The DRA does not require the use or support of any other instrumentation to carry out a complete evaluation of a digital microwave radio system from the modulator input to the demodulator output. All the system elements between these points can be tested, including the operation of the diversity combiners.

Fully featured

The DRA can be controlled remotely via dial-up RS-232, and data can be downloaded via RS-232 to a PC, where further analysis can be performed. The DRA is fully configurable using combinations of receivers and fade simulators.

General Specifications

Analysis	ITU-T G.821/G.826, dispersion signatures, M curves, C-N/rsi, time series, BER distribution and burst length, RSL, IBAD/IBPD, 3D correlations
Receiver	20 to 200 MHz narrow and wide band, IBAD/IBPD
Fade Simulation	20 to 200 MHz, precision output level (0.5 dB), continuously variable delay (0.5 to 10 ns), programmable notch trajectories
Error Counter	100 Mbit/s, gate input, TTL/ECL/HP-ECL compatible counter input

Ordering Information

DRA-M150

Contact:
Martin Communications Pty Ltd.
Unit 40/45 Gilby Rd. Mt Waverley,
Victoria, 3149
AUSTRALIA
Tel: (+613) 9558 9866
FAX: (+613) 9558 9393
E-mail: martin@martin.com.au
WWW: <http://www.ozemail.com.au/~mcomltd>

Lightwave and Communications

Lightwave Signal Analyzers & Accessories HP 71400C, 71401C, 11980A

*Calibrated measurements
of intensity modulation*

22 GHz bandwidths

RIN measurements to -165 dB/Hz

*Interferometer for laser
linewidth and chirp
measurements*

**Calibrated measurements
of high-speed modulation,
laser linewidth, and chirp**

The HP 71400C and 71401C lightwave signal analyzers combine HP's high-performance microwave and RF spectrum analyzers with a sensitive, wide-bandwidth optical-receiver module, producing calibrated instrumentation for characterizing semiconductor lasers, laser transmitters, optical modulators, and detectors.

Featuring bandwidths from 100 kHz to 22 GHz and wavelength operation from 1200 to 1600 nm or, with Option 850, from 750 to 870 nm, the HP 71400C easily and accurately makes measurements of relative intensity noise (RIN), linewidth, and modulation performance on a single-mode optical fiber. The HP 71401C has an upper frequency limit of 2.9 GHz with the same features and functions as the HP 71400C.

The key to HP's lightwave signal analyzers is the HP 70810B lightwave module. Consisting of an optical attenuator, broadband photodetector, microwave preamplifier, and optical power meter, the HP 70810B compensates for photodetector responsivity and preamplifier gain variations. Frequency-response and mismatch losses are corrected (see Figure 1).

The HP 71400C incorporates the fundamentally mixed HP 71210C microwave analyzer and can achieve a

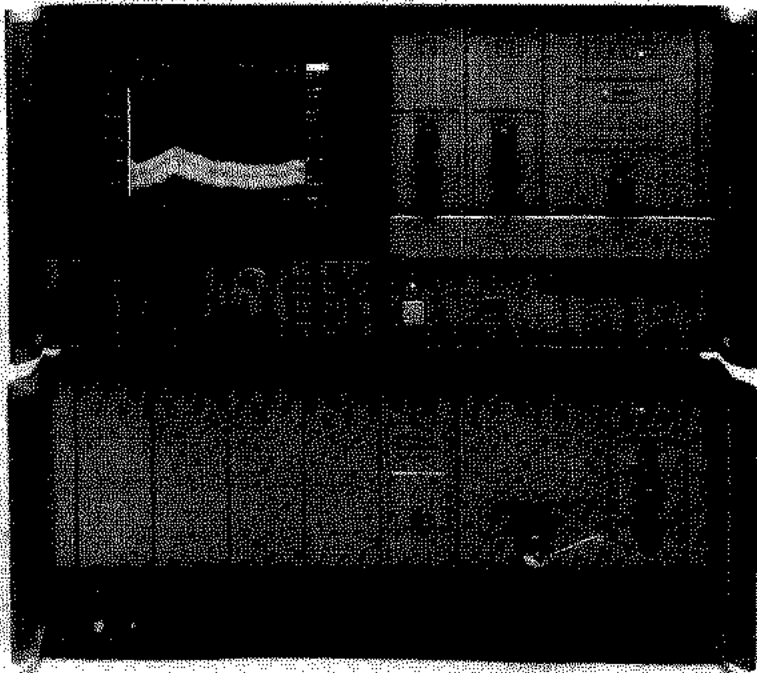

HP 71400C system is a part of the flexible MMS system.

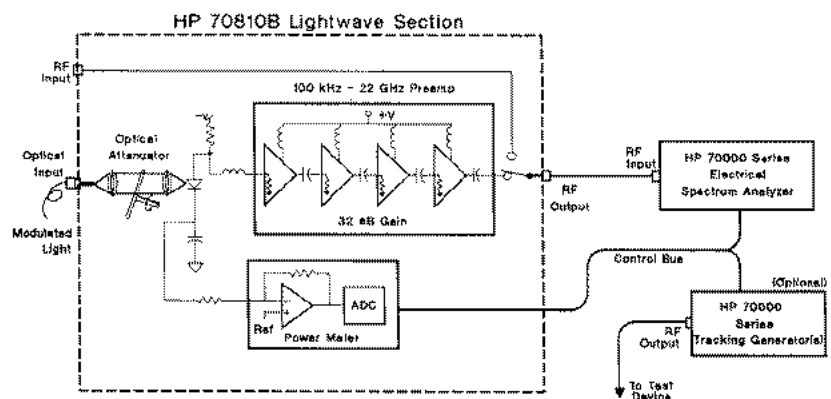

Figure 1. Block diagram of an HP 71400 system showing detail of HP 70810 module

displayed average noise level better than -65 dBm (optical) in a 10 Hz bandwidth. This is low enough to observe and measure the intensity noise and RIN levels of most

semiconductor lasers. The built-in attenuator enables you to test lasers with up to 1 watt of power, providing you with outstanding measurement dynamic range.

Lightwave and Communications

Lightwave Signal Analyzers

HP 71400C/71401C

Versatile measurement capability

Modulation and signal distortion measurements

The HP 71400C and 71401C display baseband intensity modulation, harmonics, and laser noise floor. You can see the laser's intensity noise, relaxation oscillation peak, baseband intensity modulation, and signal harmonics out to 22 GHz. Monitor your analog transmissions and find difficult digital system problems with the time-proven power of frequency-domain signal analysis. At the same time, monitor the laser's average power with the vertical power bar. Or you can utilize the analyzer's calibrated receiver as a standard to test your photodetectors, with the electrical input port (see Figure 2).

RIN and laser intensity-noise characterization

The HP 71400C and 71401C feature two relative intensity noise (RIN) measurement capabilities: total RIN and laser RIN. The total RIN capability reads out the total system RIN at a frequency. This measurement includes the receiver shot noise, the thermal noise, and the laser's intensity noise at a marker location. The total RIN measurement can be performed quickly and can measure RIN values to -150 dBc/Hz on a 1 mW laser.

The laser RIN measurement is an advanced measurement routine that removes the photodiode's shot noise and the analyzer's thermal noise contributions from the total noise. This provides laser RIN measurement values as much as 16 dB below the thermal and shot-noise contributions, and values up to -165 dBc/Hz can be measured (see Figure 3).

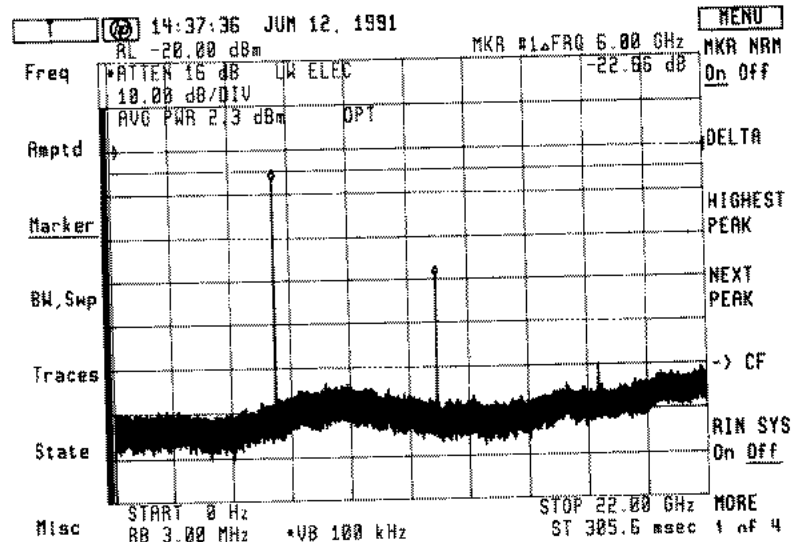

Figure 2. Harmonic distortion on an analog modulated laser

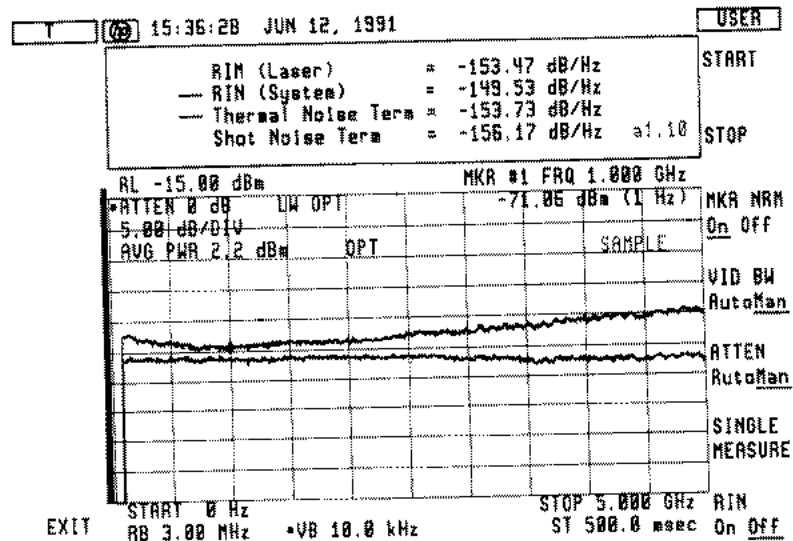

Figure 3. RIN measurement personality

Lightwave and Communications

Lightwave Signal Analyzers

HP 71400C/71401C

Modulation frequency response

The shape and amplitude of a laser's intensity-noise spectrum provides useful information. The laser's relaxation resonance appears as a peaking in the intensity noise floor of the laser. The maximum modulation rate of the laser is directly related to the location of this resonance peak, which is related to the bias-current level. More current will widen the resonance and shift its position higher in frequency.

Adding the HP 70300A and 70301A tracking generator modules allows you to simultaneously display the laser's frequency response and relaxation oscillation, or intensity noise resonance, for any laser-bias level. This display will show you if the laser is achieving its full frequency response potential or if there are electrical problems causing response degradations.

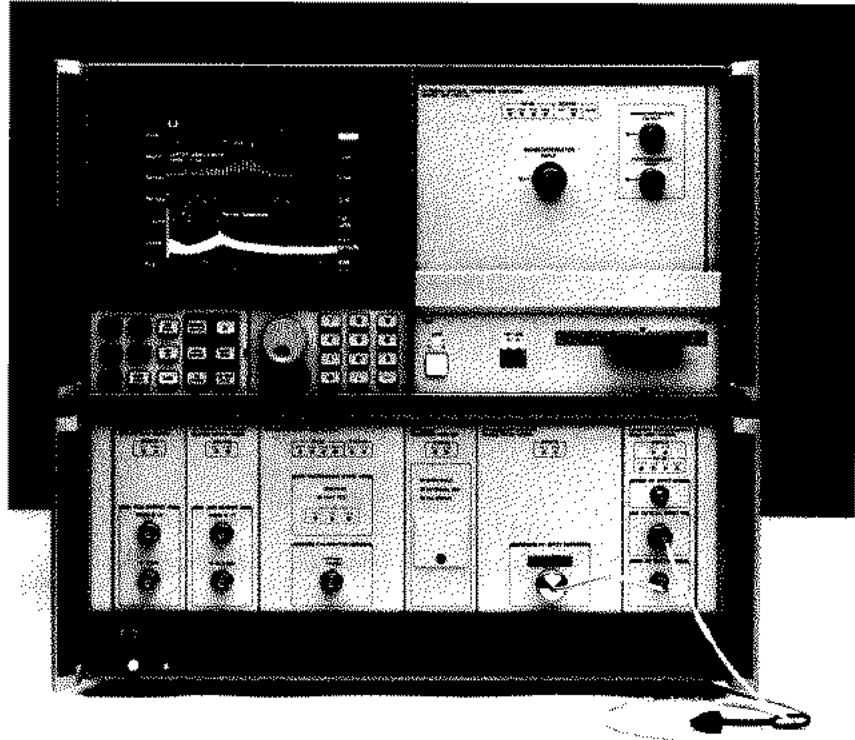

Add linewidth and chirp measurements

Linewidth

Add the HP 11980A fiber optic Mach-Zehnder interferometer and the HP 70880A automatic linewidth personality to a lightwave signal analyzer to measure linewidth. The HP 11980A uses the self-homodyne technique to translate the spectral line from the terahertz region to 0 Hz. The HP 70880A automatic linewidth personality is an advanced measurement program that measures the linewidth of distributed feedback (DFB) lasers and determines the fit and deviation of the laser from the ideal Lorentzian lineshape. This linewidth personality makes linewidth measurements automatically from the instrument keys and remotely across the HP-IB bus.

Chirp

With the HP 11980A, and a modulation source that can be gated on and off, you can measure chirp and

The MMS system allows an OSA to be combined and displayed with the signal analyzer.

frequency modulation (FM) characteristics of single-line lasers. Modulating a laser's injection current causes the laser to chirp or change frequency (FM). This incidental FM, or chirp, can be an unwanted by-product, causing chromatic dispersion on the transmission line, or it can be a desired feature for lightwave systems, allowing FSK (frequency shift keying) or other FM communications techniques to be used.

Sinewave, squarewave, and PRBS modulation will each cause different amounts of chirp. But large amounts of amplitude modulation from any source will cause large FM deviations. The HP 71400C can measure FM deviations up to 44 GHz.

Upgrade your system to include spectral information

The HP 71400C and 71401C are part of the modular measurement system

(MMS). This system provides an easy way to add additional capability to your lightwave signal analyzer. Shown here is the HP 70951B optical spectrum analyzer module with the HP 71400C lightwave signal analyzer. As a system, you can concurrently monitor the spectral and modulation characteristics of the laser. Or you can simultaneously measure the linewidth and sidemode suppression ratio on the same display.

Extended calibration

The HP 71400C and 71401C come standard with extended calibration that provides additional flatness corrections for the analyzer. Option 020 adds this extended calibration to the HP 70810B module bought separately for use in an existing HP 71210C or HP 71100C system.

Lightwave and Communications

Lightwave Signal Analyzers

HP 71400C/71401C

Specifications

Specifications describe the instrument's warranted performance over the 0° to 55° C temperature range, except where noted. All specifications apply after the instrument temperature has stabilized and after self-calibration routines have been run. Characteristics provide information about non-warranted instrument performance in the form of nominal values. All amplitude specifications are in optical dB unless noted otherwise.

	HP 71400C		HP 71401C	
	Standard	Opt 850	Standard	Opt 850
Wavelength range (characteristic)	1200 to 1600 nm	750 to 870 nm	1200 to 1600 nm	750 to 870 nm
Frequency range	100 kHz to 22 GHz		100 kHz to 2.9 GHz	
Average power accuracy (at 1300 and 1550 nm standard, or at 830 nm for Opt. 850)	Factory-calibrated: ± 0.65 dB ± 5.0 nW \pm connector variation ¹ User-calibrated: ± 0.05 dB ± 5.0 nW \pm power meter accuracy (by external power meter) ²			
Modulated power				
Amplitude accuracy at 100 MHz	20° to 30° C, ± 1.0 dB 0° to 55° C, ± 1.8 dB		20° to 30° C, ± 1.0 dB 0° to 55° C, ± 1.8 dB	
Frequency response relative to 100 MHz	100 kHz to 2.9 GHz 20° to 30° C, ± 1.0 dB 0° to 55° C, ± 1.3 dB		100 kHz to 2.9 GHz 20° to 30° C, ± 1.0 dB 0° to 55° C, ± 1.3 dB	
	2.9 to 22 GHz 20° to 30° C, ± 1.0 dB 0° to 55° C, ± 3.0 dB			
RF input frequency response ³				
100 kHz to 2.9 GHz	± 2.3 dB (electrical)		± 1.8 dB (electrical)	
2.9 to 22 GHz	± 2.8 dB (electrical)			
Displayed average optical noise level (10 Hz RBW, 3 Hz VBW)				
Ref. level ≤ -40 dBm	Standard	Opt 850	Standard	Opt 850
100 kHz to 1 MHz	-51 dBm	-47 dBm	-51 dBm	-47 dBm
1 MHz to 10 MHz	-57 dBm	-53 dBm	-57 dBm	-53 dBm
10 MHz to 100 MHz	-62 dBm	-58 dBm	-62 dBm	-58 dBm
100 MHz to 8 or 2.9 GHz	-66 dBm	-62 dBm	-66 dBm	-62 dBm
8 to 16 GHz	-66 dBm	-62 dBm		
16 to 22 GHz	-60 dBm	-56 dBm		
Harmonic distortion (10 MHz to 22 or 2.9 GHz)	70 dB below fundamental with modulated power ≤ -30 dBm		70 dB below fundamental with modulated power ≤ -30 dBm	
Input return loss (with HMS-10/HP)				
Internal	< 40 dB		< 40 dB	
Total	< 35 dB		< 35 dB	
Maximum input power (with 30 dB Atten.)				
Average power	+15 dBm		+15 dBm	
Modulated power	+15 dBm		+15 dBm	
Input connectors	Single-mode fiber connectors: Diamond HMS-10/HP, FC/PC, ST, DIN, Biconic			

¹ Connector reflections and losses vary with factors such as connector type, quality, cleanliness, temperature, damage, wear.

² Applies to any wavelength with average power readout set to match external calibrated optical power meter. Does not include VSWR losses.

³ Assumes extended system calibration (Opt. 020). Otherwise, use module specifications for frequency response.

Lightwave and Communications

Lightwave Section

HP 70810B

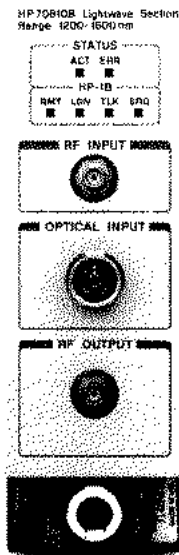

The HP 70810B lightwave section is a lightwave receiver module for the HP 70000 modular measurement system (MMS). Consisting of an optical attenuator, broadband photodetector, microwave preamplifier, and optical power meter, the module combines with an HP 70000 series spectrum analyzer to create an HP 71400 series lightwave signal analyzer.

The lightwave section has a wavelength range of 1200 to 1600 nm, a detected modulation bandwidth of 100 kHz to 22 GHz, and a built-in RF amplifier of 32 dB that provides optical sensitivity of -60 dBm in a 10 Hz bandwidth. The module also features both optical and electrical input capability.

As a slave module to the MMS local oscillator, the HP 70810B allows you to access the functions of the electrical spectrum analyzer in an HP 71400 series system.

Features

The HP 70810B lightwave section adds a number of features to the HP 71400C and 71401C lightwave signal analyzers. These include downloadable programming capability, which allows the analyzer to perform simple or complex tasks and calculations without an external controller. Downloadable programs (DLPs) can be written or loaded into the analyzer.

Other features are a memory card reader, which allows traces, states, and DLPs to be read from or stored on ROM and RAM cards; an HP-HIL keyboard interface; screen titles; mass storage to an external disk; limit lines; panning; and operation with non-lightwave modules.

Measurement enhancements

A DLP is provided with the HP 70810B lightwave section for measuring the RIN of lasers to -165 dB/Hz. The program subtracts receiver shot noise and thermal noise contributions from the total noise of the system.

The HP 70810B contributes several other enhancements to the lightwave signal analyzers. Measurement of relative power is now independent of the power-bar display. A linear graphic display has been added with an optical mode in power units or an electrical mode in power or voltage units. Trace information can be displayed in lightwave-electrical units, and optical power meter information can be displayed in lightwave-optical units.

A user-power function allows the lightwave signal analyzer to be referenced to another calibrated optical-power standard. The adjustment range of the user power function has been extended from ± 2 dB to ± 300 dB around the factory calibration point.

Lightwave and Communications

Lightwave Section

HP 70810B

Specifications

The HP 70810B lightwave section is for use with the HP 71400C and 71401C lightwave signal analyzers or the HP 71210C or 71100C spectrum analyzers. It can be used as a standalone optical-to-electrical converter housed in an HP 70001A mainframe.

Wavelength range (characteristic)	Standard	Opt 850
	1200 to 1600 nm	750 to 870 nm
Frequency range	100 kHz to 22 GHz	
Average power accuracy (at 1300 and 1550 nm standard; 830 nm for Option 850)	Factory-calibrated: ± 0.65 dB ± 5.0 nW \pm connector variation ¹ User-calibrated (by external power meter): ± 0.05 dB ± 5.0 nW \pm power meter accuracy ²	
Responsivity (characteristic) given for each instrument and accurate to $\pm 20\%$		
Nominal value at 100 MHz	Standard 1200 V/W	Opt 850 500 V/W
Noise equivalent power (dBm/ $\sqrt{\text{Hz}}$)	Standard	Opt 850
100 kHz to 1 MHz	-55	-51
1 to 10 MHz	-61	-57
10 to 100 MHz	-66	-62
100 MHz to 8 GHz	-70	-66
8 to 16 GHz	-68	-64
16 to 22 GHz	-64	-60
Frequency response (relative to 100 MHz) ³	Corrected	
100 kHz to 2.9 GHz	± 2.0 dB (electrical)	
2.9 to 22 GHz	± 5.0 dB (electrical)	
(characteristic uncorrected response is < 25 dB electrical, 100 kHz to 22 GHz)		
Maximum input power (with 30 dB atten)	Average +15 dBm	Modulated +15 dBm
Harmonic distortion (output ≤ -10 dBm)	43 dB (electrical) below fundamental	
Input return loss (with HMS-10/HP)		
Internal	< 40 dB	
Total	< 35 dB	
Electrical input flatness, corrected (characteristic) ³	Amplitude Error	
100 kHz to 6 GHz	± 1.4 dB (electrical)	
6 to 12 GHz	± 1.6 dB (electrical)	
12 to 16 GHz	± 2.0 dB (electrical)	
16 to 22 GHz	± 2.2 dB (electrical)	
Electrical output return loss (characteristic)		
100 kHz to 6 GHz	± 12.0 dB (electrical)	
6 to 12 GHz	± 10.5 dB (electrical)	
12 to 16 GHz	± 8.5 dB (electrical)	
16 to 22 GHz	± 7.5 dB (electrical)	
Bypass mode insertion loss		
100 kHz to 6 GHz	± 2.5 dB (electrical)	
6 to 12 GHz	± 3.7 dB (electrical)	
12 to 16 GHz	± 4.9 dB (electrical)	
16 to 22 GHz	± 5.2 dB (electrical)	
Input connectors	Single-mode fiber connectors: Diamond HMS-10/HP, FC/PC, ST, DIN, Biconic	

¹ Connector reflections and losses vary with factors such as connector type, quality, cleanliness, temperature, damage, wear.

² Applies to any wavelength with average power readout set to match external calibrated optical power meter. Does not include VSWR losses.

³ Specifications achieved by applying module responsivity or frequency correction factors stored in module memory.

Ordering Information

HP 71400C lightwave signal analyzer,
100 kHz to 22 GHz

Opt 001 add HP 11980A fiber-optic
interferometer

Opt 121 add distribution amplifiers

Opt 850 operate 750 to 870 nm

HP 71401C lightwave signal analyzer,
100 kHz to 2.9 GHz

Opt 850 operate 750 to 870 nm

HP 70810B lightwave section, 100 kHz
to 22 GHz

Opt 020 system adjustment and
calibration

Opt 850 operate 750 to 870 nm

Firmware upgrades (required with
spectrum analyzer date codes of
901008 or earlier)

Opt 098 system LO firmware
upgrade

Opt 099 system LO firmware
upgrade

**Connector interface options for all
models** (choose one)

Opt 011 Diamond HMS-10

Opt 012 FC/PC

Opt 013 DIN 47256

Opt 014 ST

Opt 015 biconic

Additional interface connectors

(compatible with HP 71400C,
71401C, and 70810B)

HP 81000AI Diamond HMS-10

HP 81000FI FC/PC

HP 81000SI DIN 47256

HP 81000VI ST

HP 81000WI biconic

Recommended accessories

HP 11980A fiber-optic
interferometer

HP 70880A linewidth
measurement personality

Lightwave and Communications

Fiber-Optic Interferometer

HP 11980A

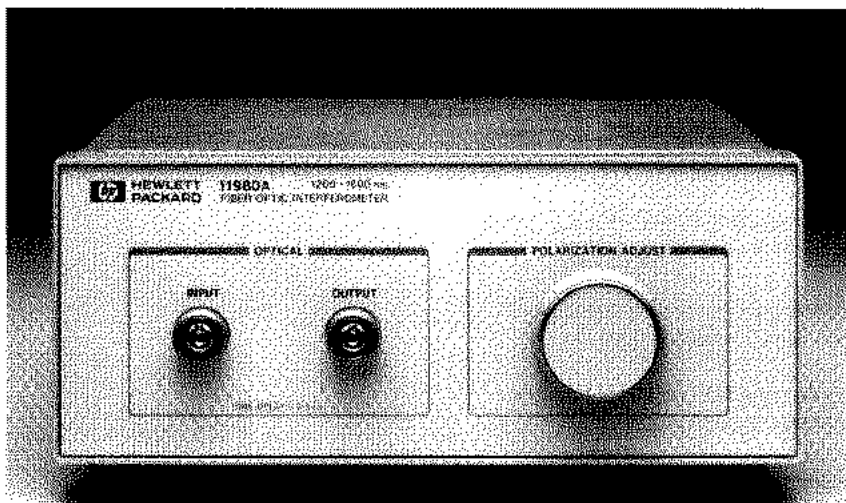

The HP 83810B includes the HP 11982, cables and personality program, and various RF spectrum analyzers.

The HP 11980A is a Mach-Zehnder interferometer of fixed delay. Used with an HP 71400 series or HP 83810B lightwave signal analyzer, it allows you to measure chirp and frequency modulation (FM) on DFB lasers. Traditional measurements of laser linewidth on single-line lasers can also be made.

Together, the interferometer, lightwave signal analyzer, and a gateable RF source permit the display of a true power spectrum of single-frequency lasers. This includes the display of intensity modulation linewidth and components of chirp caused by the intensity modulation.

Option 005 replaces the standard 0.76 km of delay with 5.2 km to measure laser linewidth down to 30 kHz.

Specifications

Optical insertion loss

1300 nm: < 8 dB
1550 nm: < 8 dB

Wavelength range (characteristic)

1250 to 1600 nm

Delay time (characteristic)

3.5 μ s
25 μ s with Opt. 005

Optical connectors

Single-mode fiber connectors: Diamond HMS-10/HP, FC/PC, ST, biconic, DIN

Ordering Information

HP 11980A fiber-optic interferometer
Opt 005 5 km of fiber (μ s delay)

Connector interface options
(choose one)

- Opt 011 Diamond HMS-10S
- Opt 012 FC/PC
- Opt 013 DIN 47256
- Opt 014 ST
- Opt 015 biconic

Lightwave and Communications

Optical Spectrum Analyzers

HP 71450B, 71451B and 71452B

Excellent sensitivity, dynamic range, and wavelength accuracy

LED, Fabry-Perot or DFB laser characterization

Stimulus response system for optical components

Polarization dependent loss versus wavelength

EDFA characterization with all common optical test methods

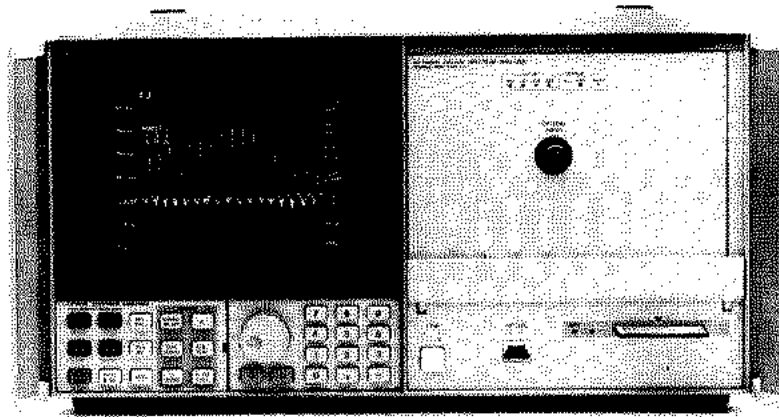

HP 71450B, 71452B

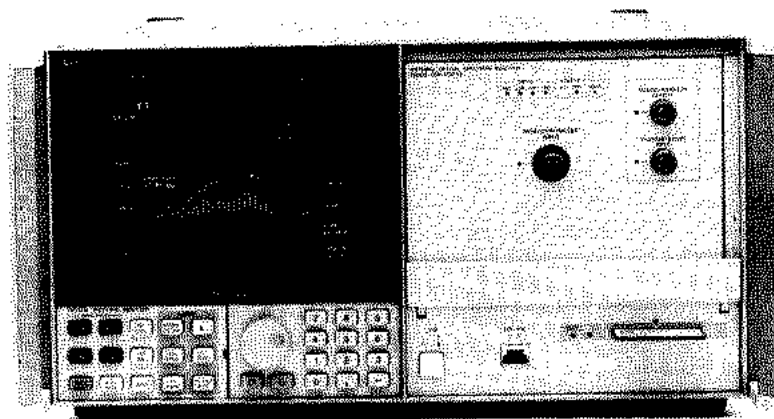

HP 71451B

The HP 71450B, 71451B, and 71452B are diffraction-grating based optical spectrum analyzers (OSAs) using a unique double-pass monochromator design which offers the dynamic range of a double monochromator and the sensitivity of a single monochromator. All OSAs perform quick, precise spectral measurements from 600 to 1700 nm. They offer critical measurement capabilities needed in the laboratory and on the production floor:

The HP 71450B, 71451B, and 71452B provide unprecedented performance with their outstanding dynamic range, sensitivity, high amplitude and wavelength accuracy, and polarization insensitivity. These instruments perform measurements quickly, especially when high sensitivity is required. Capable of sweeping 40 nm in 50 ms with reduced dead time, the analyzers can save hours of measurement time. In addition, the HP 71450B, 71451B, and 71452B can be left continually sweeping; you no longer need to stop the sweep to save wear and avoid costly repairs.

Each analyzer consists of a mainframe, color display, optical spectrum analyzer module, and a special keypad for ease of use. As part of the HP 70000 modular measurement system, the HP 70950B, 70951B and 70952B optical spectrum analyzer modules can be added to an existing MMS system.

Lightwave and Communications

Optical Spectrum Analyzers

HP 71450B, 71451B and 71452B

Small and rugged

Both analyzers are contained in a single 9-inch high package. They operate over the full 0° C to 55° C temperature range and are tested to rigorous Class B2 environmental specifications, including those for vibration and shock. Now you can safely transport the instrument into the next room or across the country with confidence.

Ease of use

All features of an electrical spectrum analyzer are available in these optical analyzers. Electronic modification of screen data allows immediate wavelength-position or span adjustment possible. Fully-variable spans, with full control over sweep speed, sensitivity, and resolution, as well as choice of manual or automatic settings, make measurements easy.

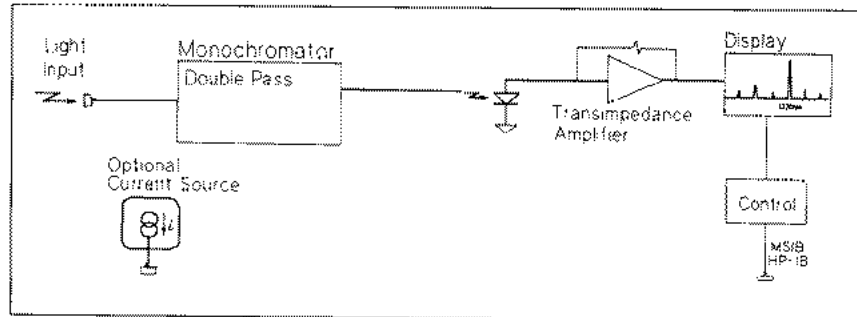

Figure 1. Standard operating mode of the HP 71450B or 71452B

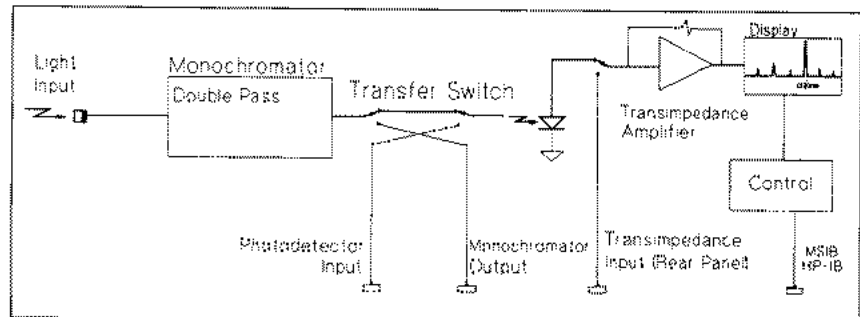

Figure 2. HP 71451B in OSA mode

The HP optical spectrum analyzers include automatic features. An automeasure function quickly locates the signal, zooms in, and centers the display. An auto-align feature automatically centers the light on the photodiode for optimum amplitude accuracy and removes the need for fiber alignment on the monochromator output. The HP 71451B extends the capabilities of the HP 71450B by adding an optical transfer switch. This switch provides access to key points in the spectrum analyzer block diagram. The monochromator output allows the input optical signal to be filtered by the monochromator with all resolution bandwidths available. The output is for use with other equipment in the analysis of WDM systems, mode partition noise analysis, and time

resolved chirp. The photodiode input allows a signal to bypass the monochromator and be input directly into the photodiode. With the display in zero span and a slow sweep time, you can dynamically adjust a laser for maximum power output (see Figures 1 and 2).

The HP 71452B is the result of the optical amplifier research, development, and manufacturing industries' need for innovative measurement techniques and stringent performance specifications. Its block diagram is identical to the HP 71450B. However, the HP 71452B contains enhanced optical components for excellent accuracy in characterizing optical amplifiers.

Lightwave and Communications

Optical Spectrum Analyzers

HP 71450B, 71451B and 71452B

Source measurements

The OSAs include built-in programs for advanced measurement on DFB and Fabry-Perot lasers and LEDs. The LED measurement identifies and measures the spectral full-width half-maximum value, mean-wavelength position, and peak-power density of the LED as shown in Figure 3.

The Fabry-Perot (FP) laser measurement function measures the spectral full-width half-maximum or envelope bandwidth, center wavelength, mode spacing, and total power of the laser. The Gaussian or Lorentzian curve fit to your laser may also be displayed (see Figure 4). The DFB laser measurement function provides center wavelength, automatic side-mode suppression ratios, peak power, and stop-band characterization.

All analyzers also offer an optional current source to bias your light source. A sink or source current up to 200 mA allows continuous or variable duty-ratio current pulses. The source can be set from the front panel or over the HP-IB. You can also set the maximum current limit to avoid accidentally overdriving the laser. The current source provides a transient suppression and voltage clamping to protect your diode under test.

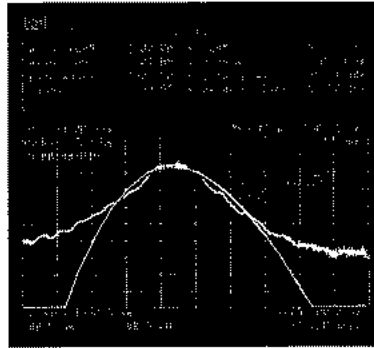

Figure 3. LED measurement

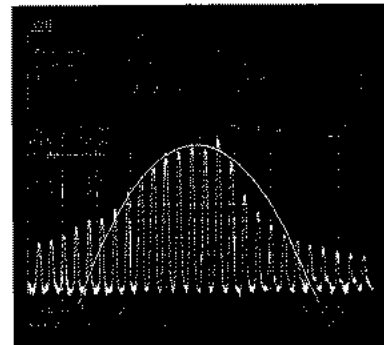

Figure 4. FP measurement

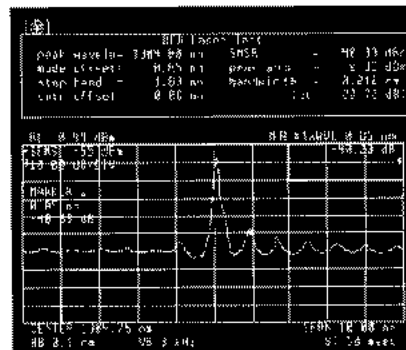

Figure 5. DFB measurement

Lightwave and Communications

Optical Spectrum Analyzers

HP 71450B, 71451B and 71452B

Stimulus response testing

The HP 71450B and 71451B optional white light source adds swept-wavelength stimulus-response test capability to your optical spectrum analyzer without increasing rack or bench space. The white light source has a wavelength range of 900 to 1600 nm. The output spectrum is filtered below 900 nm to prevent the detection of light at half the wavelength of interest. In addition, the need to frequently change the high intensity halogen lamp of your white light source has been eliminated.

The long lifetime design provides a mean time between failures (MTBF) of greater than 5000 hours. Devices such as couplers, fibers, filters, and isolators can be characterized as a function of wavelength with the HP 71450B, 71451B or 71452B. Responsivity as a function of wavelength on photodetectors and receivers can be quickly measured with the HP 71451B (see Figure 6).

Swept polarization dependent loss testing

The polarization dependent loss kit provides the capability to make swept-polarization dependent loss measurements on optical-to-optical and optical-to-electrical components and devices. Combining the HP 71451B OSA, white light source, and swept PDL kit, provides a system that can accurately measure PDL from 1250 to 1600 nm.

The swept PDL kit contains the semi-rigid multimode fiber, semi-rigid multimode adapter, polarizer, 2-meter single mode fiber with FC/PC connectors, and the HP 11896A polarization state controller. Figure 7 shows the swept PDL measurement setup.

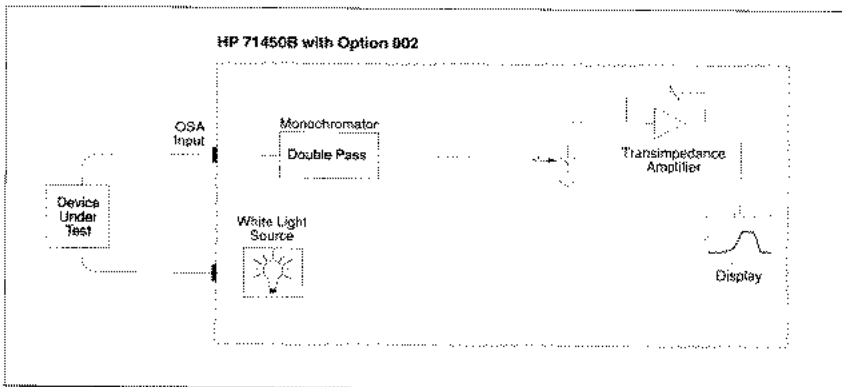

Figure 6. Stimulus response measurement setup

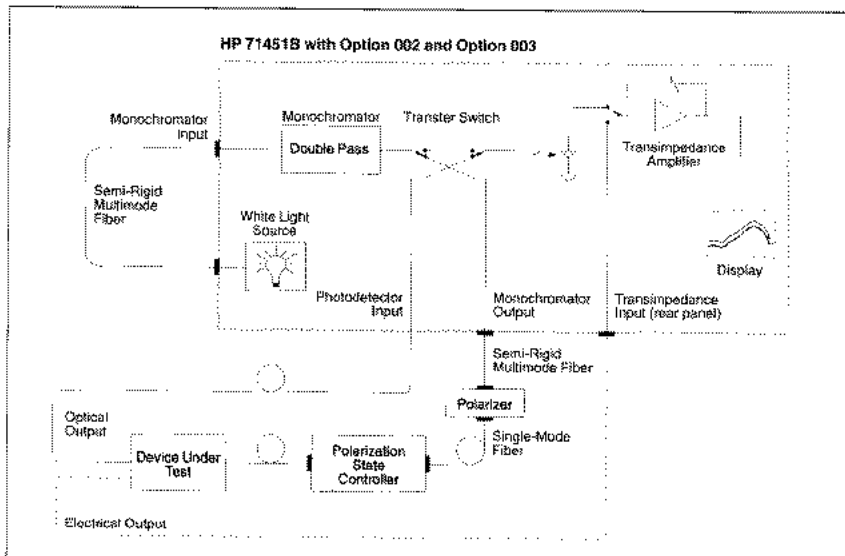

Figure 7. Swept PDL measurement setup

The polarization dependent loss is measured by viewing the output spectrum of the device under test. As the polarization state controller is varied, the maximum and minimum outputs are measured and displayed. The difference of the maximum and minimum traces is the peak-to-peak PDL of the device.

DWDM component testing

The DWDM component test kit (Option 031) augments the HP 71452B optical spectrum analyzer by adding an HP 11986A polarization controller and an HP 83438A Erbium ASE source with polarized light (Option 009). Furthermore, it removes all three EDFA test personalities from the OSA. Together, these three instruments are the core setup for testing passive components versus wavelength and polarization in the 1550 nm optical window.

Lightwave and Communications

Optical Spectrum Analyzers

HP 71450B, 71451B and 71452B

Specification Summary	HP 71450B	HP 71451B	HP 71452B
Wavelength range	600 - 1700 nm		
Span range (cont. variable)	0.2 nm - full range and zero span		
Absolute accuracy¹		± 1 nm	
after user calibration	± 0.3 nm	± 0.3 nm	± 0.2 nm
Differential accuracy for separations ≤ 20 nm ⁵		± 0.1 nm	
Tuning repeatability		± 0.005 nm	
Settability		0.005 nm	
Resolution bandwidth			
FWHM (selectable) ¹⁰	0.08, 0.1, 0.2, 0.5, 1, 2, 5, 10		
Resolution accuracy (bandwidth ≥ 0.5 nm, 1250 - 1600 nm)			
Default accuracy		± 20 %	
Using noise marker (factory calibrated)		± 3 %	
Amplitude			
Display scale	0.01 - 20 dB log, and linear		
Absolute accuracy at -30 dBm, 1300 nm		± 0.5 dB	
Scale fidelity (autorange off)	± 0.1 dB	± 0.1 dB	± 0.05 dB
(autorange on)	± 0.2 dB	± 0.2 dB	± 0.07 dB
Flatness ⁷			
<input type="checkbox"/> 1290 nm - 1330 nm	± 0.25 dB	± 0.25 dB	± 0.25 dB
<input type="checkbox"/> 1530 nm - 1570 nm	± 0.25 dB	± 0.25 dB	± 0.2 dB
<input type="checkbox"/> 1250 nm - 1600 nm	± 1 dB	± 1 dB	± 1 dB
Polarization dependence²			
1300 - 1320 nm ¹	± 0.5 dB	± 0.5 dB	± 0.125 dB
1542 - 1562 nm ¹	± 0.5 dB	± 0.5 dB	± 0.05 dB
Sensitivity			
600 - 750 nm (second order only)		-60 dBm	
750 - 900 nm (second order)		-75 dBm	
750-900 nm (first order)		-70 dBm	
900-1100 nm		-75 dBm	
1100 - 1600 nm		-90 dBm	
1600 - 1700 nm		-80 dBm	

Lightwave and Communications

Optical Spectrum Analyzers

HP 71450B, 71451B and 71452B

Specification Summary	HP 71450B	HP 71451B	HP 71452B
Dynamic range in 0.1 nm resolution ^{1,6}		-50 dB at ≥ ± 1 nm	<i>Option 122, 0.2 nm resolution</i>
600 - 1700 nm ⁵		-55 dB at ≥ ± 0.5 nm	-58 dB at ≥ ± 0.5 nm
1250 - 1600 nm			-65 dB at ≥ ± 1.0 nm
1250 - 1600 nm, chop mode on ⁵		-70 dB at ± 0.5 nm, ± 1 nm, ± 5 nm	
Pulse response			
≥ 2 μs after rising edge ⁵	± 0.2 dB	± 0.2 dB	—
≥ 10 μs after falling edge, extinction > 27 dB	± 0.2 dB ⁵	± 0.2 dB ⁵	± 0.2 dB
Signal-to-noise measurement⁴			
CW	± 0.63 dB	± 0.63 dB	± 0.18 dB
Pulse mode	± 0.68 dB	± 0.68 dB	± 0.29 dB
Input power			
< 0.05 dB compression level (within selected resolution)		> +10 dBm	
Maximum safe input level		+ 20 dBm per 5 nm, + 30 dBm total	
Input return loss⁷			
With 9/125 μm fiber		> 35 dB	
With 50/125 μm fiber ⁵	28 dB	28 dB	N/A
With 62.5/125 μm fiber ⁵	26 dB	26 dB	N/A
Sweep time⁵			
Max. sweep rate		40 nm / 50 ms	
Sweep cycle time			
50 nm span (auto zero off) ⁵		< 180 ms	
Full span		< 1 s	
Additional Specifications for the HP 71451B			
Monochromator output (into 62.5 μm fiber)			
Insertion loss (850/1300/1550 nm, 1st order)		< 18 dB/< 7 dB/< 10 dB	
Polarization dependence in the range 1250 - 1600 nm ²		± 0.5 dB	
Resolution accuracy in the range 1250 - 1600 nm ³		± 20 %	
Photodetector input (power meter mode)			
Absolute accuracy at -30 dBm, 1300 nm ⁸		± 0.35 dB	
Sensitivity ⁵		-95 dBm (1250 - 1600 nm), -85 dBm (600-1700 nm)	
1 dB compression level		> + 7 dBm	
Maximum safe input power		+ 20 dBm	
Flatness for ≤ 2 dBm input		± 0.4 dB (1250 - 1600 nm)	

Lightwave and Communications

Optical Spectrum Analyzers

HP 71450B, 71451B and 71452B

Opt. 002 Built-in White Light Source

Light source output	
Wavelength	900 - 1700 nm (filtered below 850 nm)
Spectral power density	
Into 9/125 μ m fiber	0.2 nW/nm (900 - 1600 nm), 0.1 nW/nm (1600 - 1700 nm)
Into 50/125 μ m fiber ⁵	10 nW/nm
Into 62.5/125 μ m fiber ⁵	25 nW/nm
Stability over 10 minutes⁵	\pm 0.02 dB
Lamp lifetime⁵	Mean Time Between Failure > 5000 Hrs.

Stimulus Response System Specification

Passive optical-to-optical devices (with HP 71450/51B)

Measurement range	
1250 - 1600 nm and 9/125 μ m fiber	0 to 33 dB in 10 nm RBW (36 dB typ)
1000 - 1600 nm and 50/125 or 62.5/125 μ m fiber	0 to 40 dB (10 nm RBW)
Dynamic range⁵	
1250 - 1600 nm and 9/125 μ m fiber	36 dB (with 10 nm RBW)
1000 - 1600 nm and 50/125 or 62.5/125 μ m fiber	36 dB (10 nm RBW)

Measurement accuracy	
1250 - 1600 nm and 9/125 μ m fiber	\pm 0.1 dB (excluding connector repeatability)
1000 - 1600 nm and 50/125 or 62.5/125 μ m fiber	\pm 0.2 dB (excluding connector repeatability)

Optical-to-electrical devices (with HP 71451B only)	
Minimum responsivity ⁵	0.01 A/W
Accuracy ⁵	\pm 0.9 dB (excluding connector repeatability)

Opt. 003 Swept PDL Kit (with HP 71451B only)

Accuracy (1250 - 1600 nm)	
Optical-to-optical devices (external photodetector)	+ 0.1/-0.05 dB
Optical-to-electrical devices ⁵	+ 0.075/-0.025 dB
Polarization extinction measurement range ⁵	0 to 30 dB

Notes

- After user calibration, with applied input fiber 9/125 μ m.
- For resolutions \geq 0.2 nm.
- For resolutions \geq 0.5 nm.
- Calculated ($1.15 \times$ RSS) from polarization sensitivity, scale fidelity, resolution bandwidth, accuracy, and pulse response (in pulse mode).
- Characteristic.
- Excluding multiple order grating response.
- Depends on the quality of the attached connector.
- 20-30 $^{\circ}$ C.
- Assumes polarization controller achieves all desired states of polarization. Specification applies for devices with less than 5 dB loss.
- Resolution of 10 nm is available in first order only.

Measurement Summary

Measurement	HP 71450B	HP 71451B	HP 71452B
-------------	-----------	-----------	-----------

O/E and E/O Devices

<input type="checkbox"/> Power spectrum, total power	good	good	good
<input type="checkbox"/> Noise density (W/nm)	good	good	good
<input type="checkbox"/> LED, FP, DFB characterization	good	good	good
<input type="checkbox"/> Detector responsivity	n/a	recommended	n/a

BWDM Passive Components

<input type="checkbox"/> Insertion loss	good	good	good
<input type="checkbox"/> Polarization dependent loss	n/a	recommended (Opt 003)	good
<input type="checkbox"/> Polarization mode dispersion	good	good	good

Optical Amplifiers

<input type="checkbox"/> Output spectrum	good	good	recommended
<input type="checkbox"/> Gain and noise figure	*	*	recommended
<input type="checkbox"/> Noise gain profile	*	*	recommended
<input type="checkbox"/> Noise gain peak	*	*	recommended

Wavelength Division Multiplexing Systems

<input type="checkbox"/> Output spectrum	good	good	recommended
<input type="checkbox"/> Non-linear effects	good	good	recommended

Supported Fiber Type	up to 62.5/125 μ m	up to 62.5/125 μ m	9/125 μ m
-----------------------------	------------------------	------------------------	---------------

*With reduced accuracy only

Lightwave and Communications

Optical Spectrum Analyzers

HP 71450B, 71451B and 71452B

Ordering Information

HP 71450B optical spectrum analyzer¹

- Opt 001** programmable current source
- Opt 002** built-in white light source
- Opt 051** EDFA test personality
- Opt 052** EDFA time-domain test personality
- Opt 053** EDFA noise-gain profile measurement personality
- Opt 1CM** rack mount kit

HP 71451B optical spectrum analyzer¹

- Opt 001** programmable current source
- Opt 002** built-in white light source
- Opt 003** swept PDL kit
- Opt 051** EDFA test personality
- Opt 052** EDFA time-domain test personality
- Opt 053** EDFA noise-gain profile measurement personality
- Opt 1CM** rack mount kit

HP 71452B optical spectrum analyzer¹ (*includes Opt 051 EDFA interpolation test personality, Opt 052 EDFA time-domain test personality, and Opt 053 EDFA noise-gain profile measurement personality*)

- Opt 001** programmable current source
- Opt 002** built-in white light source
- Opt 1CM** rack mount kit
- Opt 031** DWDM component test kit

HP 70950B optical spectrum analyzer module¹

- Opt 001** programmable current source
- Opt 002** built-in white light source
- Opt 051** EDFA test personality
- Opt 052** EDFA time-domain test personality
- Opt 053** EDFA noise-gain profile measurement personality

HP 70951B optical spectrum analyzer module¹

- Opt 001** programmable current source
- Opt 002** built-in white light source
- Opt 003** swept PDL kit
- Opt 051** EDFA test personality
- Opt 052** EDFA time-domain test personality
- Opt 053** EDFA noise-gain profile measurement personality

HP 70952B optical spectrum analyzer¹

(*includes Opt 051 EDFA interpolation test personality Opt 052 EDFA time-domain test personality, and Opt 053 EDFA noise-gain profile measurement personality*)

- Opt 001** programmable current source
- Opt 002** built-in white light source

HP 70953A time-domain extinction upgrade

(*For the HP 71450A, 71451A (HP 70950A, 70951A) only. After ordering the HP 70953A, the customer will receive packing material and instructions on how to return the HP 70950A, 70951A module to the factory where the upgrade will be done.*)

Accessories

Interface connectors

HP 81000AI Diamond HMS-10

HP 81000FI FC/PC

HP 81000GI D4

HP 81000KI SC

HP 81000SI DIN 47256

HP 81000VI ST

HP 81000WI biconic

HP 81000FB FC/PC bare fiber adapter

HP 85680-60093 BNC-to-SMB cable

The time-domain test personality requires one and the noise-gain profile measurement personality requires two trigger cables.

¹ FC/PC connector interface (HP 81000FI) is standard on each model.

Lightwave and Communications

Jitter Analyzer System

HP 71501C

Jitter transfer, tolerance, generation

50 Mb/s to >12 Gb/s

Test clock-recovery chips to complete systems

The HP 71501C jitter analyzer system provides advanced analysis of high-speed digital communication waveforms and the components which generate them. The HP 71501C can be configured as a powerful jitter analyzer when used with an HP 71603B 3 Gb/s BERT or the HP 71612A 12 Gb/s BERT. The HP 71501C is frequency agile, performing an extensive range of jitter tests from as low as 50 Mb/s to as high as 12 Gb/s or any rate between. Automatic tests include SDH/SONET compliance for:

- Jitter transfer
- Jitter tolerance
- Jitter generation/output jitter

Use standard jitter test templates for 155 Mb/s, 622 Mb/s, 2488 Mb/s, and 9952 Mb/s testing, or create your own custom templates to define the jitter magnitudes and frequencies as well as the data rate.

The HP 71501C can perform jitter measurements on devices where the input and output rates are different, such as a multiplexer or demultiplexer. Diagnostic measurements can also be made to display the demodulated jitter spectrum and waveform. Thus the HP 71501C is a powerful jitter analysis system for a broad range of devices from the semiconductor chip level all the way to a functioning communications system.

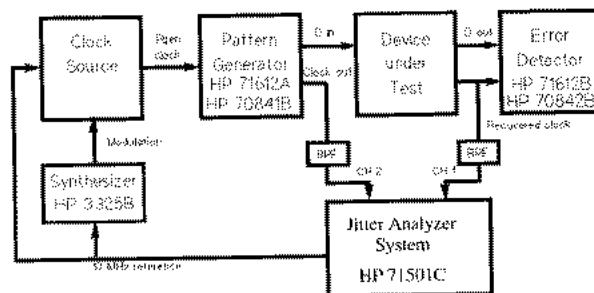
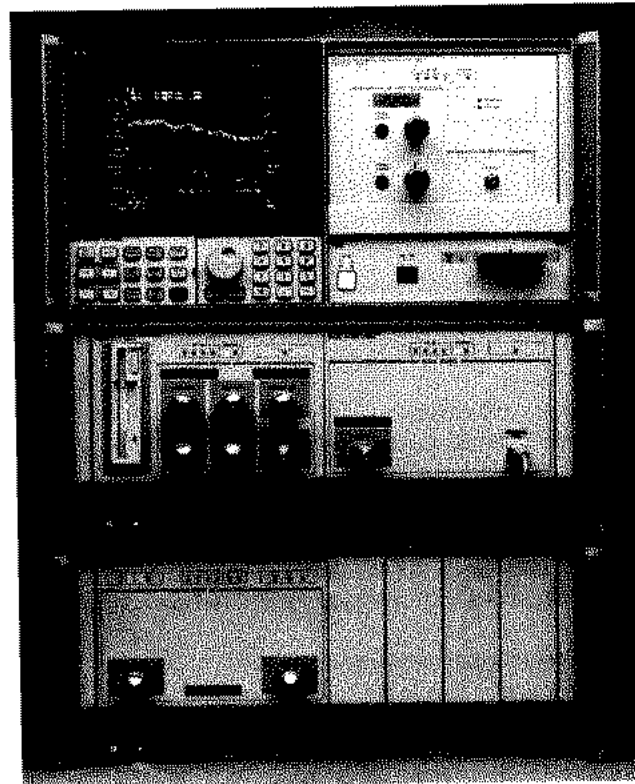

HP4 - Bardass Title

Figure 1. HP 71501C configured in the jitter analysis system

Lightwave and Communications

Jitter Analyzer System

HP 71501C

Jitter transfer

The HP 71501C performs automatic compliance or custom tests of jitter transfer. The HP 71501C controls the HP 3325B signal generator (jitter modulation source), HP clock source¹, and HP pattern generator to produce a data waveform with the specific input jitter levels and frequency ranges set by the standard or user-defined test. The HP 71501C then simultaneously measures both the input and output jitter levels to the device under test (DUT) to determine the jitter transfer function. Input rates and output rates need not be identical.

Jitter tolerance

Jitter tolerance measurements are made in a similar method as the jitter transfer measurement. With the HP 71501C as the system controller, the required jitter input signal is sent to the DUT. Standard or user-defined jitter inputs are used. The HP BER detector is monitored to determine the occurrence of errored bits. The test can be configured to verify performance at pre-defined jitter levels, or it can be put into a search mode to determine the maximum jitter levels and frequencies that the DUT can tolerate.

¹ A specific set of clock sources are compatible with the HP 71501C system: HP 70311A Option H08, HP 83752A, HP 70340A, and HP 83732B. Choice of clock source depends on data rates and jitter modulation requirements. Refer to HP 71501C literature for further information.

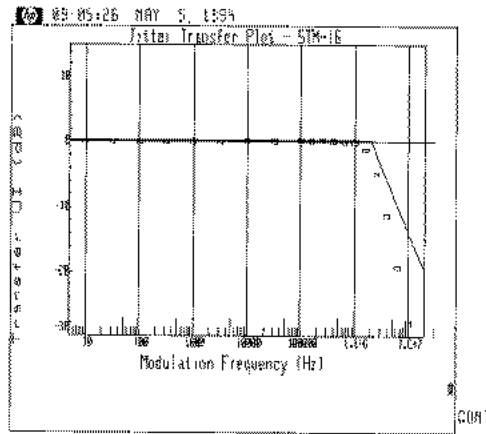

Figure 2. Jitter transfer measurement of a clock recovery circuit operating at 2.488 Gbit/s is measured to the G.958 standard.

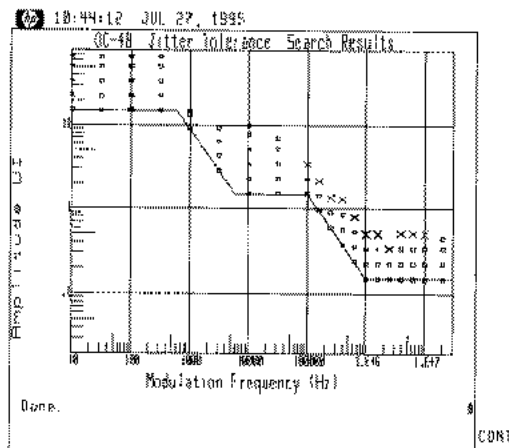

Figure 3. Jitter tolerance test shows compliance as well as margin levels.

Lightwave and Communications

Jitter Analyzer System

HP 71501C

Jitter output and generation

The HP 71501C will measure both jitter output and jitter generation as defined by the G.958 standard. Both RMS and peak-to-peak measurements are made. Measurement bandwidths are automatically set to the requirements of the standards. For custom tests, bandwidths can be set by the user.

Diagnostic measurements

Not only can the HP 71501C test for compliance to jitter test standards, it also has the ability to perform diagnostic measurements to aid in understanding and solving jitter related problems. Both the frequency spectrum and time-domain waveform of the jittered clock signal can be viewed. The spectrum and waveform of the jitter signal, extracted from the jittered clock, can also be automatically recovered and displayed.

Eye-diagram analysis

The HP 71501C can also be configured as an eye-diagram analyzer. Loading the eye-diagram analyzer software personality, the HP 71501C can perform many of the functions available in a high-speed sampling oscilloscope. In addition to conventional oscilloscope functions, the HP 71501C can generate continuous traces using HP Eyeline mode. This allows viewing of pattern dependencies in high-speed transmitters. Also, internal filtering can be performed to significantly reduce broadband noise without reducing measurement bandwidth. Data sequences that lead to eye mask violations can be captured and displayed using eyeline mode. The HP 71501C also can process data with user-defined software filters showing the effect of the filter on the shape of the eye without having to build and connect the actual hardware filter.

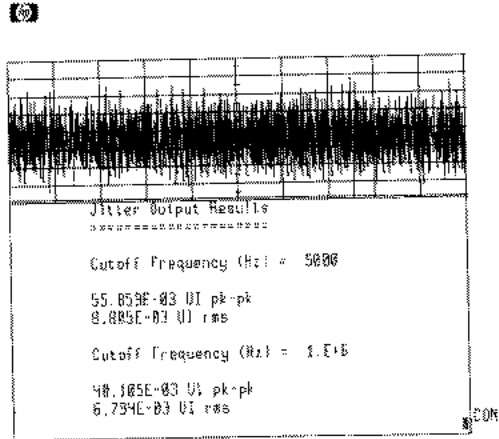

Figure 4. Jitter output measurement. Both peak-to-peak and RMS levels are determined.

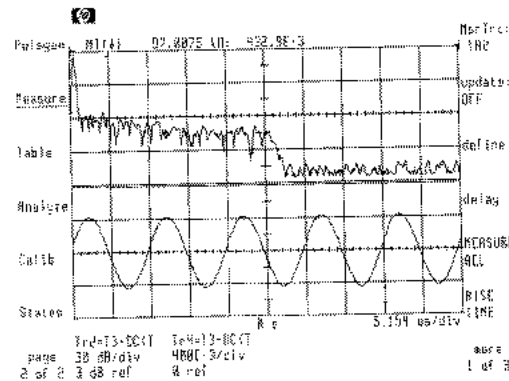

Figure 5. Frequency spectrum and waveform of a demodulated jitter signal are displayed.

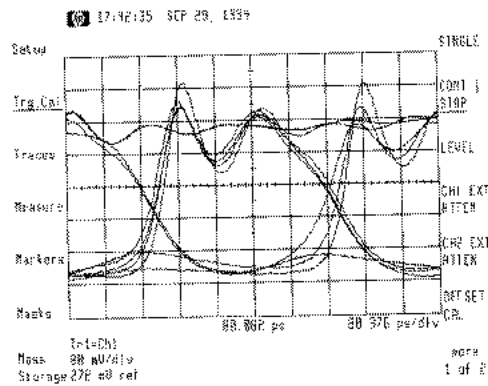

Figure 6. Individual traces can be viewed using HP Eyeline mode.

Lightwave and Communications

Jitter Analyzer System

HP 71501C

Specifications

Specifications describe the instrument's warranted performance over the 0° C to +55° C temperature range unless otherwise stated. Typical values describe expected but non-warranted performance.

Jitter analyzer measurement characteristics

Bit rate	50 Mbit/s - 12 Gbit/s
Jitter Frequency Range	10 Hz - 20 MHz
Amplitude level accuracy	± 2%
Jitter transfer measurement accuracy	± 0.05 dB
Intrinsic jitter	
Measurement range	0.005 UI - 0.5 UI rms, 5 UI pk-pk
Measurement accuracy	±10% + 0.005 UI rms
High-pass frequency range	100 Hz - 1 MHz

Note: The data rate range, as well as the jitter magnitudes and bandwidth that can be produced by the measurement system, are a function of the clock source used to drive the HP pattern generator. Four sources are supported by the HP 71501C including the HP 70311A, option H08, HP 70340A, HP 83752A, and HP 83732B. Choice of a source depends upon the data rates and jitter bandwidths to be tested. Typical performance is as follows:

Source	Data rates	Jitter range	Peak jitter magnitude
HP 70311A Opt. H08	100 Mb/s to 3 Gb/s	10 Hz to 20 MHz	33 UI at 2.5 Gb/s 5 UI at 155 Mb/s
HP 83752A/ 83732B	50 Mb/s to >12 Gb/s	300 Hz to 10 MHz	16 UI
HP 70340A	1 Gb/s to >12 Gb/s	50 Hz to 5 MHz	33 UI

Eye-diagram analysis specifications

Vertical Specifications

Bandwidth (-3 dB)	
Extended BW off	20 GHz
Extended BW on	40 GHz
Measurement level accuracy	1 % of pk-pk signal level ± 0.5 mV ± 5° C from Cal
Noise Floor (@ 1 GHz)	<1.4 mV rms

Input channels

Operating input range < ± 320 mV (including dc offset)

Maximum safe input voltage without damage ± 2V pk-pk

CAUTION: INPUTS ARE DC COUPLED

Number of input channels 2

Input connectors 2.4 mm (male)

Note: Includes 2 adapters (2.4 mm (f) to 3.5 mm (f))

Nominal input impedance 50 ohms

Programmable dc offset ± 320 mV

Horizontal specifications

Time scale range (full scale is 19 divisions)

5 ps/div to 100 s/div

Delta time measurement accuracy the greater of:
< timespan/ # of trace points; or 1 ps

Time delay Eye mode (clock frequencies > 10 MHz):
- (timespan/2) to
+ (1000 x timespan)

Eye line and pattern modes

Pattern frequency ≥ 10 MHz · (timespan/2)
to +(1000 x timespan)

Pattern frequency ≤ 10 MHz ± 2 pattern lengths

Time delay between channels (uncorrected) < 10 ps

Note: Time delay between channels (up to 20% of the timespan) is correctable in software.

Trigger specifications

Trigger sensitivity 65 mV pk-pk (typical) (dc to 40 GHz)

Jitter < 2.5 ps rms

Ordering Information

HP 71501C jitter analyzer system

Includes: HP 70004A color display and mainframe, HP microwave transition analyzer module, HP 3325B function generator (jitter source), HP 83752A clock source, jitter analysis personality, eye-diagram analysis personality, adapter and cable accessories, 155, 622, 2488, and 9953 Mb/s bandpass filters, and user manual sets for the HP 71501C, HP 70820A, and HP 70004A.

Opt 001 delete HP 83752A clock source

Opt 003 delete HP 3325B generator (jitter source)

Opt 004 delete hardware bandpass filters

Opt 005 add eye-diagram analysis software

Opt 200 delete HP 70004A color display and mainframe

Opt 201 replace HP 70004A display with HP 70001A mainframe

Note: The HP 71501C is incompatible with the HP 70205A monochrome display.

Opt 810 adds rackmount slide kit

Opt 908 adds rack flange kit (for instruments without handles)

Opt 910 adds extra set of user manuals

Opt 913 adds rack flange kit (for instrument with handles)

Opt 915 adds service manuals

Lightwave and Communications Gigabit Error Performance Analyzers and Pattern Generators

HP 71603B, 71604B,
71612A Series, 71501C

*User-programmable patterns
with screen-based editor*

*Hitless switching between
two programmed patterns*

Trigger anywhere in pattern

*Automatic setting of clock/data
phase and data decision threshold*

Fast transition times, low jitter

Full jitter analysis capability

Advanced eye-diagram analysis

*Burst mode capability for fiber
loop testing*

4 sub-rate outputs for WDM testing

Location of specific errored bits

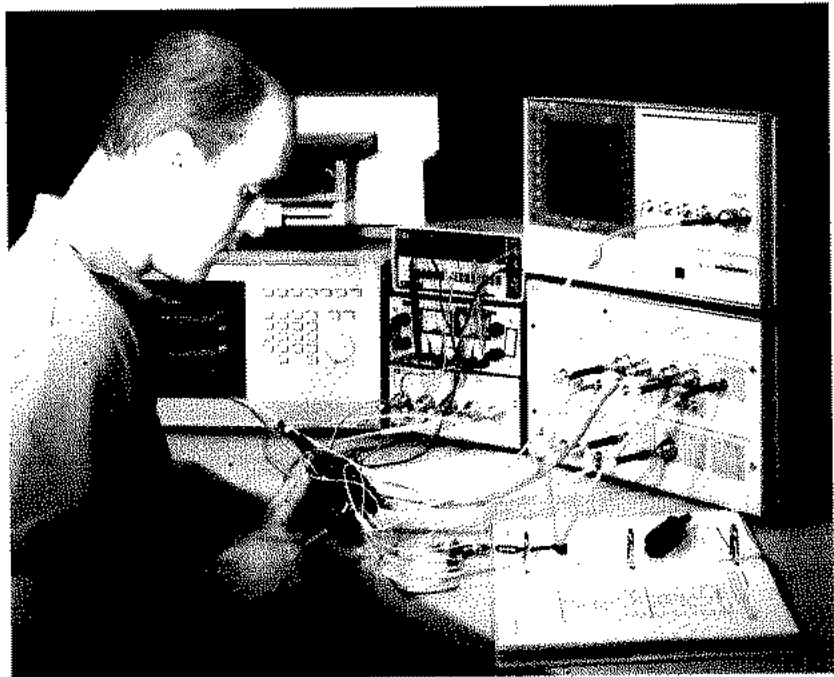

HP 71603B 3 Gb/s error performance analyzer

The HP 71603B error performance analyzer consists of a pattern generator, a synthesized clock source, and error detection modules configured in the modular measurement system. The HP 71603B covers the range of 100 Mb/s to 3 Gb/s and features automatic clock and data alignment for rapid setup of the error detector. It measures waveforms badly distorted by noise, jitter, phase adjustment, and inter-symbol interference caused by the high-resolution setting of decision threshold.

Applications include component testing—GaAs and high speed silicon components; optical components—and module and system testing—SONET and SDH; broadband video and ATM; submarine cable; high speed LAN and computer peripheral communication.

Specifications (typical)

Bit rate	100 Mb/s to 3 Gb/s
Rise time (20% to 80%)	< 90 ps
Patterns	2^7-1 to $2^{31}-1$; user patterns to 4 Mb
Data and data outputs	0.25 V to 2 V p-p amplitude; +1 V to -3.75 V range
Data input sensitivity	< 50 mV @ 2.5 Gb/s
Decision threshold voltage	+1 V to -3 V, resolution 1 mV
Clock/data delay	± 1 ns; resolution 1 ps
Measurements	Error count, ratio, errored intervals; G.821 analysis; eye width and height

Lightwave and Communications Gigabit Error Performance Analyzers and Pattern Generators

HP 71603B, 71604B, 71612A Series, 71501C

HP 71612A Series 12 Gb/s testers

The HP 71612A series of 12 Gb/s testers includes an error performance analyzer, a pattern generator, and an error detector. These instruments have functionality similar to that of the 3 Gb/s series. User pattern length has been increased to 8 Mb, and error location analysis has been added. The HP 71612A Option UHF error performance analyzer and Option UHG pattern generator have four substrate pattern outputs at one quarter of the output rate.

Applications include the simulation of SONET and SDH frames at the STM-64/STS-192 transmission rate and margin testing up to 12 Gb/s, all made possible by the increased speed and pattern size of this series. A burst mode feature allows fiber optic loop tests, and error location analysis allows identification of pattern-dependent errors for user-defined patterns.

Specifications (typical)

Bit rate	1 to 12 Gb/s (optional) 100 Mb/s to 12 Gb/s
Patterns	Same as HP 71603B; user patterns extended to 8 Mb
Transition times (10% to 90%)	< 30 ps
Jitter	< 20 ps p-p
Data and data outputs	0.5 V to 2 V p-p amplitude; +1.5 v to -3.0 V range
Data input sensitivity	< 100 mV @ 10 Gb/s
Decision threshold voltage	+1 V to -3 V, resolution 1 mV
Clock/data delay	± 1 ns up to 500 MHz; 1 clock period 500 MHz to 12 GHz
Measurements	Error count, ratio, errored intervals; G.821 analysis, eye width and height; optional error location analysis

HP 71603B and 71612A advanced eye-diagram analysis

The HP 71603B and 71612A error performance analyzers can be used with the HP 83480A digital communications analyzer to create unique analysis tools for eye diagrams. You can use the HP Eyeline mode to reveal the pattern sequence causing mask violations and to remove noise from eye diagrams. You can also construct eye diagrams from continuous traces to show pattern-dependent effects.

HP 71501C jitter analysis system

You can get full jitter analysis capability with either the HP 71603B or 71612A by adding the HP 71501C. Measurements include jitter transfer, jitter tolerance, and jitter generation over the full data rate range of the error performance analyzer.

You can use the jitter analysis system to make standards-based SDH and SONET measurements. In addition, you can create custom templates for testing at other data rates, including fiber channel. Multiplexers and demultiplexers with differing input and output rates are easily characterized. For diagnostic tests, the system can be used as a calibrated jitter source.

Ordering Information

HP 71603B error performance analyzer

HP 71603B pattern generator

HP 71612A Option UHF error performance analyzer

HP 71612A Option UHG pattern detector

HP 71612A Option UHH error detector

HP 71501C jitter analysis system

HP 83480A digital communications analyzer

Measurement and functional test software

Automatic eye-diagram and Q-factor measurement

The new HP E4543A is PC software that automates commonly used measurements made by the HP 71612A 12 Gb/s error performance analyzer. The software makes it easier to characterize the eye diagram in optical line systems, a process which can be very time consuming and prone to error. The HP E4543A controls the acquisition of measurement data via the HP-IB, and it directly interprets and displays the results as eye contours and Q-factor measurements that can be used to estimate very low background error rate on lightwave systems.

Ordering information

HP E4543A PC software

Simplified testing of STM-64/ OC-192 lightwave systems

The new HP E4544A functional test software makes it easier to generate and control structured SONET and SDH systems up to 9953.28 Mb/s. The software controls the HP 71612A 12 Gb/s error performance analyzer from a PC via the HP-IB and allows you to construct SONET or SDH frames and load them into the pattern memory of the analyzer. You can edit frames to inject specific parity error and alarm conditions for qualifying and probing the response of STM-64 or OC-192 network elements under test.

Ordering information

HP E4544A functional test software

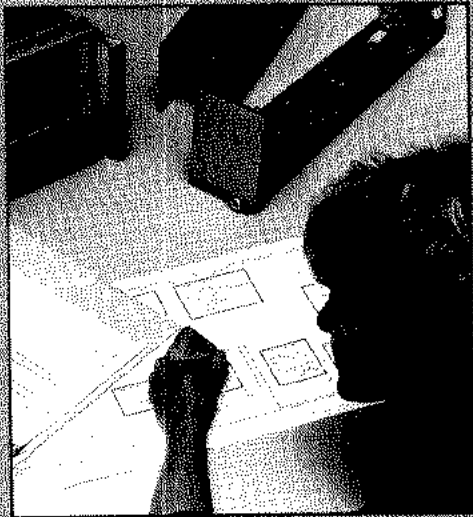

Custom module
development

Section Contents

115 System Integration

- 115 Resources and Tools
- 116 Custom Switch Matrix
- 117 Attenuator/Switch Driver
- 122 Interface Modules

124 Custom Engineering

- 124 Hewlett-Packard
- 124 Tern Engineering
- 130 Hamilton Software
- 133 Symix

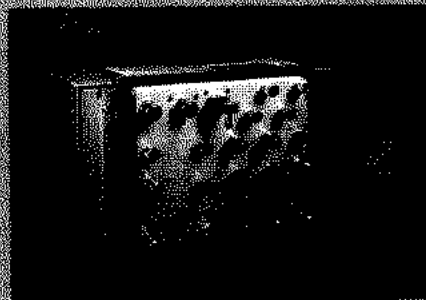

Custom switch
matrix



Engineering
resources

System Integration

Resources and Tools

Easily Integrate Your System

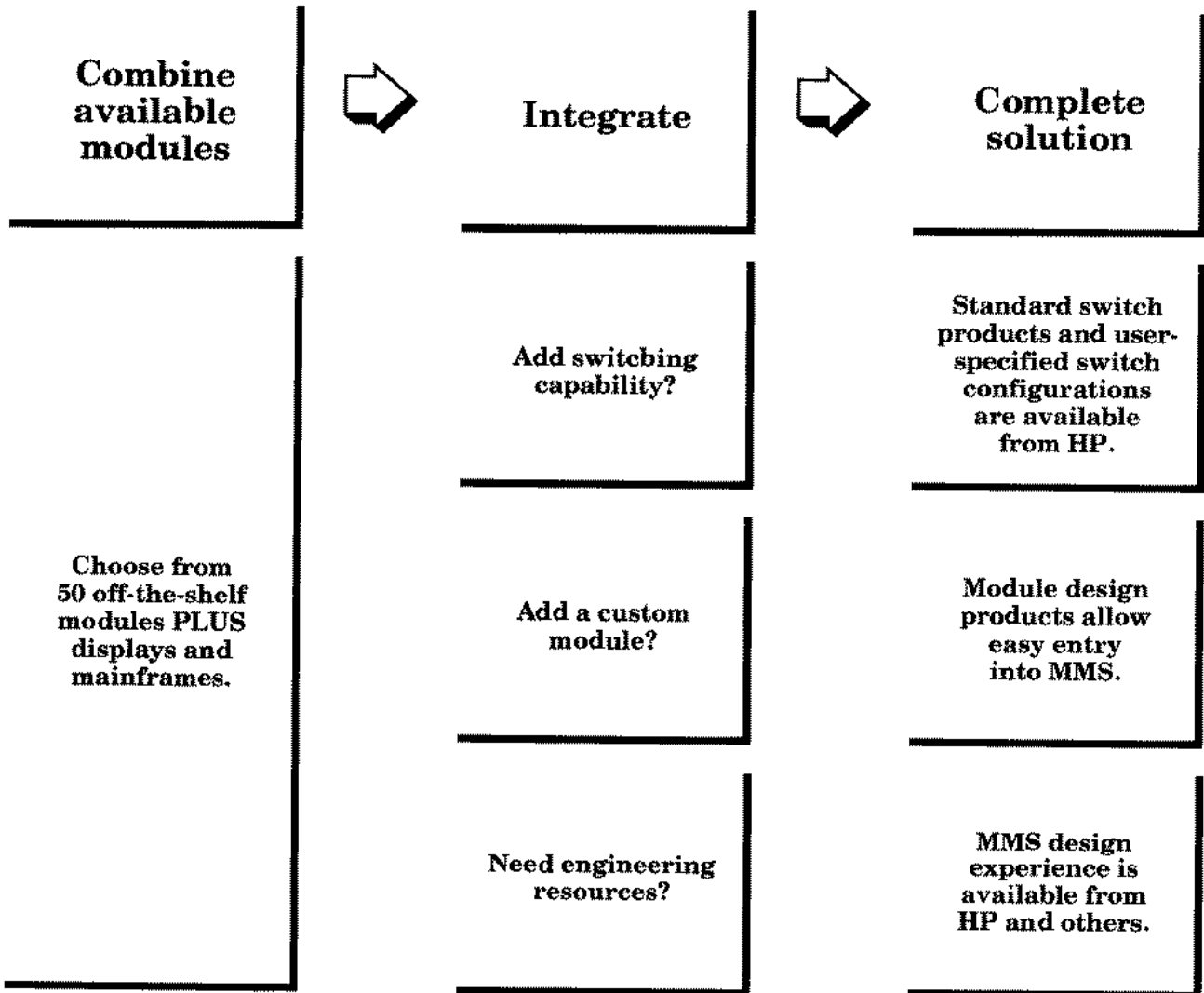

System Integration

Custom Switch Matrix

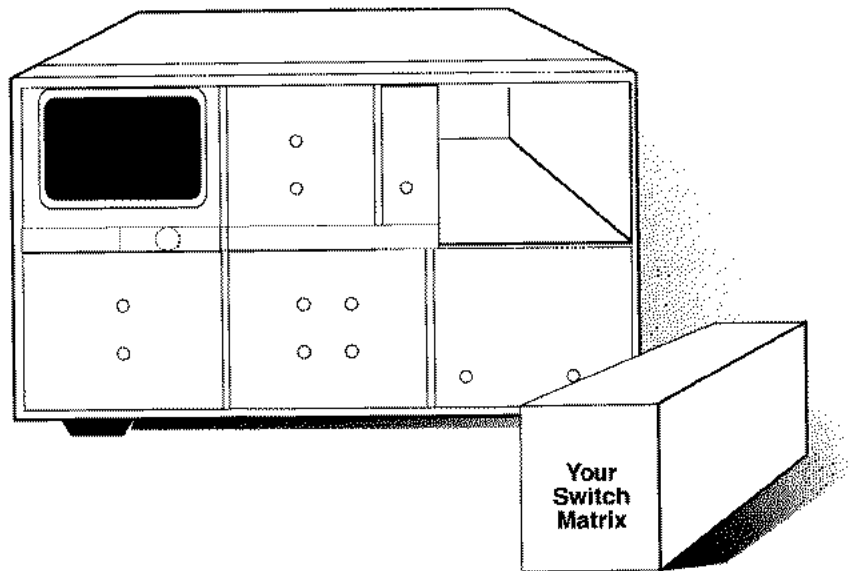

Custom interface solutions

Once you've chosen your test platform and controller, ordered your test equipment, and determined what tests need to be run in order to characterize your device under test—don't waste valuable time trying to figure out how to hook together all this gear without compromising your test objectives. HP can help solve your interconnect problems by designing a custom interface module for your automated test set. This custom module will tie all your sources and test equipment to your device under test while providing real-time feedback on system status.

More than switches

Whether your test platform is based on MMS, VXI, or System II, HP can design and fabricate an interface module composed of switches, attenuators, amplifiers, couplers, or any other required RF or microwave

functional building blocks. The module can be made to route, condition, detect, sample, and indicate the signal flow of your automated test system.

Using only the highest quality components, HP offers custom solutions that are backed by our reputation for reliability and by our worldwide customer support network.

Free up your engineers

More importantly, since HP has resources dedicated solely to solving your interface problems, the cost of an HP interface solution is often more attractive than that of dedicating your engineers to this task. And HP provides full documentation with every interface module.

In addition to custom solutions, HP has also developed a family of

standard MMS interface modules and switch/attenuator drivers.

These are described in the Instruments section under the headings HP 70611A, 70612A/C, and 70613A/C. For smaller ATE applications in MMS, these modules can provide an off-the-shelf solution to the problem of routing several test channels to a single piece of test equipment or one source to several test port locations.

For more complex problems, please contact your local HP sales representative to fill out a **MATRIX ORDERING FORM**.

Additional Information Color Brochure

*Why Buy a Switch Matrix from
Hewlett-Packard*
part no. 5966-0990E

System Integration

Attenuator/Switch Driver

HP 70611A

Capable of driving 248 devices

HP-IB/MSIB compatible

1-slot wide MMS module

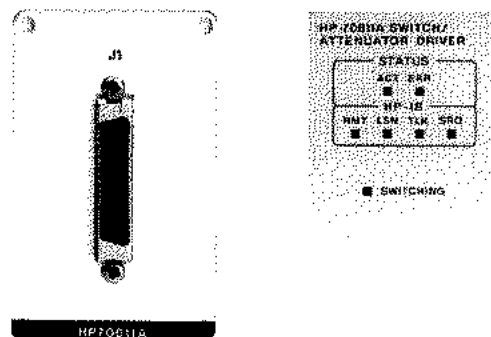

The HP 70611A is a 1-slot MMS module capable of controlling 31 electromechanical switches or attenuator switch sections. With additional driver cards, it can control a total of up to 248 devices. The basic design of the module is shown in Figure 1. The standard HP 70611A provides a manual interface through the MSIB (Modular System Interface Bus) or through the CPU interface card to the HP-IB.

Option 001 adds an output driver card (HP 84940A) that is capable of generating up to 31 individual 200 mA, 24 V dc current pulses. These low impedance output pulses can be adjusted for pulse width in order to minimize switching speed.

Used with the appropriate HP 8760 series switches or HP 8490 series attenuators, the HP 70611A can sense switch states and relay this information back to the bus. The attenuator/switch driver can remotely control an additional 217 electromechanical switches or attenuator switch settings for a total of 248. This total drive capacity is realized through the use of additional output driver cards installed in either a custom rack-mounted unit or a custom MMS interface module. See Figure 2. (For more information on the custom MMS interface module, refer to System Configuration Resources and Tools in this catalog.)

Switching speed

The switching speed of the HP 70611A is determined by (a) the pulse width selected for the output signals and (b) whether sensing is enabled or disabled. Enabling the sensing implements a built-in delay that allows the switches to settle prior to reading of their sense lines. The HP 70611A transmits output signals in groups of four. As a result, the total switching speed depends on the number of switches to be controlled and whether sensing has been implemented.

Default settings of 30 ms switching speed and the 20 ms sensing delay accommodate HP's large offering of switches and attenuators. Total switching speed is 0.4 s for 31 switches with sensing enabled.

System Integration

Attenuator/Switch Driver

HP 70611A

Programming highlights

- The HP 70611A is compatible with the standard commands for programmable instruments (SCPI).
- You can program a power-up switch state into the HP 70611A to provide a known startup configuration in case of power loss.
- Output pulse widths are programmable from 5 to 1275 ms.
- Switch sensing delays are programmable from 5 to 1275 ms.
- You can determine current open and closed switch states by querying the module.

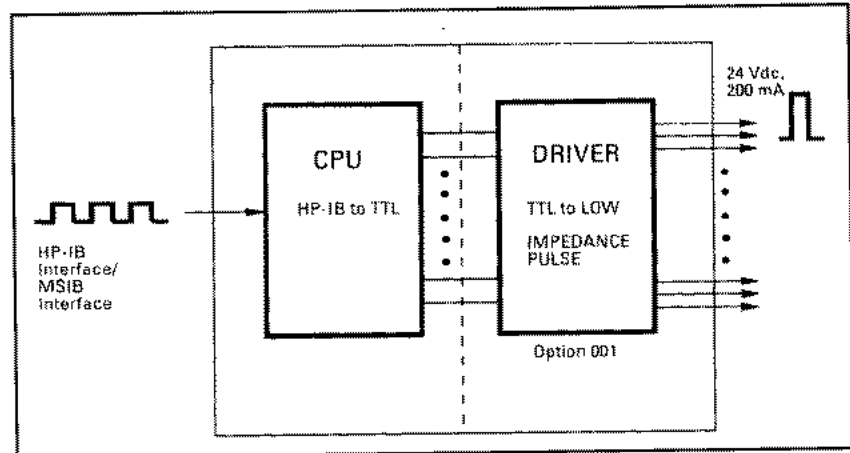

Figure 1. HP 70611A block diagram

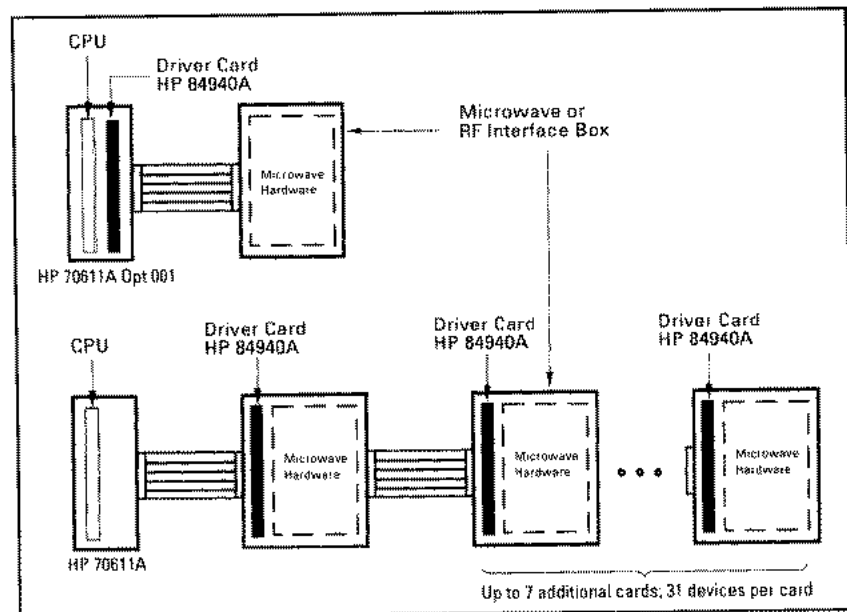

Figure 2. HP 70611A controller options

System Integration

Attenuator/Switch Driver

HP 70611A

HP 70611A manual interface

The manual interface of the HP 70611A is implemented through any MMS display. The PATH command allows you to define a set of switches and their states for incorporation into a custom menu. This set of switches can be configured with sensing enabled or disabled and with pulse width chosen. Once defined, the set of switches can be labeled alpha-numerically, saved, and recalled onto the custom menu. An HP 70004A display illustrating the status of an output driver card is shown in Table 1.

Once you have defined a set of switches (paths) and their states, you can group these paths together to make a two-level menu. This menu feature gives you quicker access to desired paths by eliminating the need to scroll through all defined paths to find the one you want. A typical user-generated menu appears in Table 2.

Group	Card	Channel	
1	00	01 02 03 04 05 06 07 08 09 10 11 12 13 14 15	Unused
	16	17 18 19 20 21 22 23 24 25 26 27 28 29 30 31	
2	00	01 02 03 04 05 06 07 08 09 10 11 12 13 14 15	Sensing
	16	17 18 19 20 21 22 23 24 25 26 27 28 29 30 31	
3	00	01 02 03 04 05 06 07 08 09 10 11 12 13 14 15	Delay
	16	17 18 19 20 21 22 23 24 25 26 27 28 29 30 31	
4	00	01 02 03 04 05 06 07 08 09 10 11 12 13 14 15	Width
	16	17 18 19 20 21 22 23 24 25 26 27 28 29 30 31	
5	00	01 02 03 04 05 06 07 08 09 10 11 12 13 14 15	Width
	16	17 18 19 20 21 22 23 24 25 26 27 28 29 30 31	
6	00	01 02 03 04 05 06 07 08 09 10 11 12 13 14 15	Width
	16	17 18 19 20 21 22 23 24 25 26 27 28 29 30 31	
7	00	01 02 03 04 05 06 07 08 09 10 11 12 13 14 15	Width
	16	17 18 19 20 21 22 23 24 25 26 27 28 29 30 31	
8	00	01 02 03 04 05 06 07 08 09 10 11 12 13 14 15	Width
	16	17 18 19 20 21 22 23 24 25 26 27 28 29 30 31	

INVERSE-Open NGRMAL-Closed
 Turn knob to select a switch or enter channel number
 Use ↑ for next card or ↓ for previous card
 Current switch: CARD 3, CHANNEL 15

Table 1. PATH definition menu

Autoselect

Switch states can be changed instantaneously using the autoselect command. When you have designated a previously defined switch state with autoselect, simply scrolling to that labeled menu item will cause the HP 70611A to transmit the signals required to implement that state. This feature is particularly useful when you need to monitor and compare system response to various state configurations in a rapid-response mode; for example, when you are scrolling through attenuator power level settings.

Group	Defined paths	Path select
Path	1. Intermod test	Path select
	2. Harmonic test	
Channel	3. Insertion loss	Group select
	4. SWR	
Config	5. Isolation	Group select
	6. 5 dB attenuation	
Misc	7. 10 dB attenuation	Label
	8. 15 dB attenuation	
Misc	9. 20 dB attenuation	Label
	10. 25 dB attenuation	
Misc	11. 30 dB attenuation	Label
	12. Test DUT 1	
Misc	13. Test DUT 2	Label
	14. Switch in load	
Misc	15. Antenna on line	Label
	16. Standby configuration	
Turn knob to select a switch path or to enter the path number of the desired path.		
Switch path 11 selected 30 dB attenuation		

Table 2. Typical user-generated menu

System Integration

Attenuator/Switch Driver

HP 70611A

Attenuators

Model no.	Description	Switching speed (ms)	Sensing
HP 8494, 84904	11 dB, 1 dB step attenuator	20	Yes
HP 8495, 84907	70 dB, 10 dB step attenuator	20	Yes
HP 8497, 84906	90 dB, 10 dB step attenuator	20	Yes
HP 8496	110 dB, 10 dB step attenuator	20	Yes

Switches

Model no.	Description	Switching speed (ms)	Sensing
HP 8765	Unterminated SPDT	5	No
HP 8762	Terminated SPDT	30	Yes
HP 8763	Terminated transfer	30	Yes
HP 8766K	SP3T	20	Yes
HP 8767K	SP4T	20	Yes
HP 8768K	SP5T	20	Yes
HP 8769K	SP6T	20	Yes

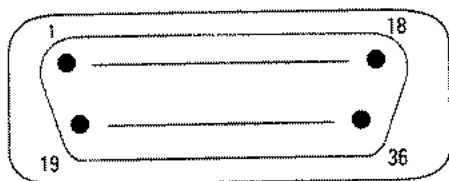

Output connectors

Standard output cable for the HP 70611A is a five foot cable with two female, 36 pin SCSI connectors.

Pin	Function	Pin	Function
1	Return	19	D6, Data line
2	Return	20	D7, Data line
3	NC	21	D8, Data line
4	NC	22	D9, Data line
5	NC	23	D10, Data line
6	NC	24	D11, Data line
7	+5 Vdc	25	D12, Data line
8	+5 Vdc	26	D13, Data line
9	+24 Vdc	27	D14, Data line
10	+24 Vdc	28	NC
11	Return	29	NC
12	Return	30	Register CLR
13	D0, Data line	31	Strobe
14	D1, Data line	32	I/O
15	D2, Data line	33	Return
16	D3, Data line	34	Return
17	D4, Data line	35	NC
18	D5, Data line	36	NC

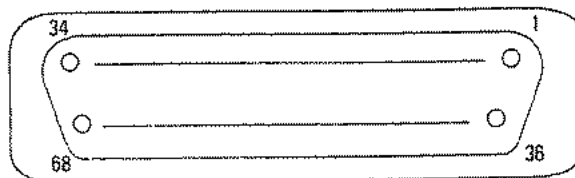

Output connectors for Option 001

Standard output cable for HP 70611A, Option 001, is a six foot cable with two male, 68 pin SCSI connectors.

Pin	Function	Pin	Function
1	Return	35	Return
2	Switch 0, open	36	Switch 0, close
3	Switch 1, open	37	Switch 1, close
4	Switch 2, open	38	Switch 2, close
5	Switch 3, open	39	Switch 3, close
6	Switch 4, open	40	Switch 4, close
7	Switch 5, open	41	Switch 5, close
8	Switch 6, open	42	Switch 6, close
9	Switch 7, open	43	Switch 7, close
10	Switch 8, open	44	Switch 8, close
11	Switch 9, open	45	Switch 9, close
12	Switch 10, open	46	Switch 10, close
13	Switch 11, open	47	Switch 11, close
14	Switch 12, open	48	Switch 12, close
15	Switch 13, open	49	Switch 13, close
16	Switch 14, open	50	Switch 14, close
17	Switch 15, open	51	Switch 15, close
18	Switch 16, open	52	Switch 16, close
19	Switch 17, open	53	Switch 17, close
20	Switch 18, open	54	Switch 18, close
21	Switch 19, open	55	Switch 19, close
22	Switch 20, open	56	Switch 20, close
23	Switch 21, open	57	Switch 21, close
24	Switch 22, open	58	Switch 22, close
25	Switch 23, open	59	Switch 23, close
26	Switch 24, open	60	Switch 24, close
27	Switch 25, open	61	Switch 25, close
28	Switch 26, open	62	Switch 26, close
29	Switch 27, open	63	Switch 27, close
30	Switch 28, open	64	Switch 28, close
31	Switch 29, open	65	Switch 29, close
32	Switch 30, open	66	Switch 30, close
33	+24 V dc	67	+24 V dc
34	Return	68	Return

System Integration

Attenuator/Switch Driver

HP 70611A

Specifications

Module size	1 slot
Switching speed	Individual switch lines can be adjusted from 5 to 1275 ms. Overall switching speed is dependent on selected switch pulse widths.
Sensing	Can be enabled or disabled. Sensing delay is programmable from 5 to 1275 ms. Sense delay and programmed switch pulse width, control the overall switching speeds of the HP 70611A. For N switches if N/4 is an integer, total switching speed is $N/4 \times (P+D)$, where P=selected pulse width and D=sensing delay. If N is not an integer, total switching speed is $(INT(N/4)+1) \times (P+D)$.
Weight	2.5 kg (5.5 lb) maximum
Operating temperature	0 to 55° C
Drive capacity	31 devices for HP 70611A, Option 001. Switches or attenuators can be connected to the HP 70611A, Option 001, via a 68-pin SCSI connector. 248 devices for the standard HP 70611A when mated with eight HP 84940A driver cards via a 36-pin daisy-chained SCSI connector.
RFI	Meets or exceeds all the pertinent requirements of MIL-STD-461B, VDE B (0871), FTZ 526, 527/1979 and FCC Part 15 Subpart J, Class B.

Ordering Information

HP 70611A attenuator/switch driver

Option 001 includes output driver card, HP 84940A. Capable of being directly wired to 31 switches or attenuator switch sections.

Option 910 extra operating/service manual

HP 84940A output driver card

Can be directly wired to 31 switches or attenuator switch sections. Designed to be incorporated into MMS or System II interface modules controlled by an HP 70611A.

System Integration

Interface Modules

HP 70612A/C and 70613A/C

MMS switch matrix

HP-IB and manual control

Custom configuration

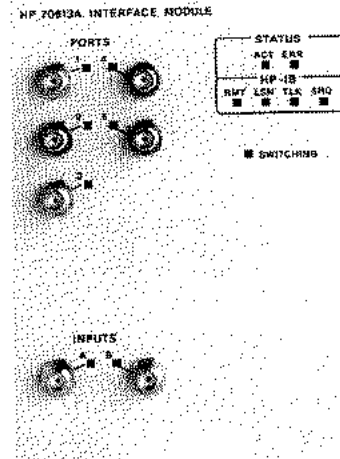
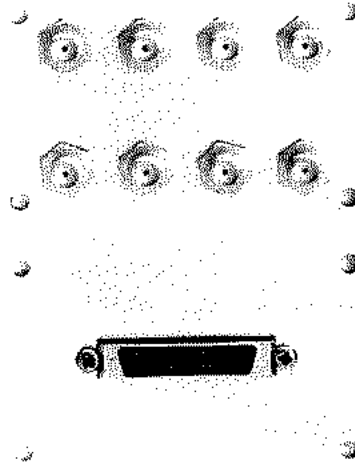

The HP 70612A/C and 70613A/C interface modules give MMS designers an off-the-shelf solution to their interconnection problems. These standard modules, illustrated on the next page, are 1x6 and 2x5 common highway switch matrixes. They are available in several frequency ranges covering to 26.5 GHz and are 2-slot MMS modules. The HP 70612 and 70613 combine the functions of the HP 70611A switch driver with the switch hardware.

In addition to routing signals between sources and devices under test, the HP 70612A/C and 70613A/C feature attenuator options for adjusting signal strengths from 0 to 110 dB in 1 dB steps. Input ports terminated in 50 W are a standard feature.

Each module comes with front panel indicators and front panel 3.5 mm connectors. Front panel indicators alert you to current switch status. Rear panel RF connectors are also available.

Control features

These switch matrixes can be controlled remotely through HP-IB or manually using any MMS display. You can manually control individual switches or define a special manual interface. You can save and recall multiple switch states using alphanumeric labels that you specify.

The HP 70612A/C and 70613A/C can remotely or manually control up to 217 additional devices through the use of HP 84940A driver cards installed in other interface modules. These remotely located interface modules, which can be controlled by a standard HP 70612 or HP 70613, or by an HP 70611A attenuator/switch driver, consist of an HP 84940A driver card and microwave hardware in a 2 slot MMS module. These modules can be ordered as Option 011 for the HP 70612A, 70612C, 70613A, and 70613C.

In addition to these standard interface modules, HP offers the ATE test set designer custom rack-mounted or MMS-compatible interface modules containing switches, attenuators, detectors, couplers, indicators, and amplifiers.

See Custom Interface/Switch Matrix in the System Configuration and Tools section of this catalog. Refer to the HP 70612A/C and 70613A/C data set sheets for complete specifications. Also refer to the HP 70611A for additional information on the driver and manual interface contained in the HP 70612 and 70613.

System Integration

Interface Modules

HP 70612A/C and 70613A/C

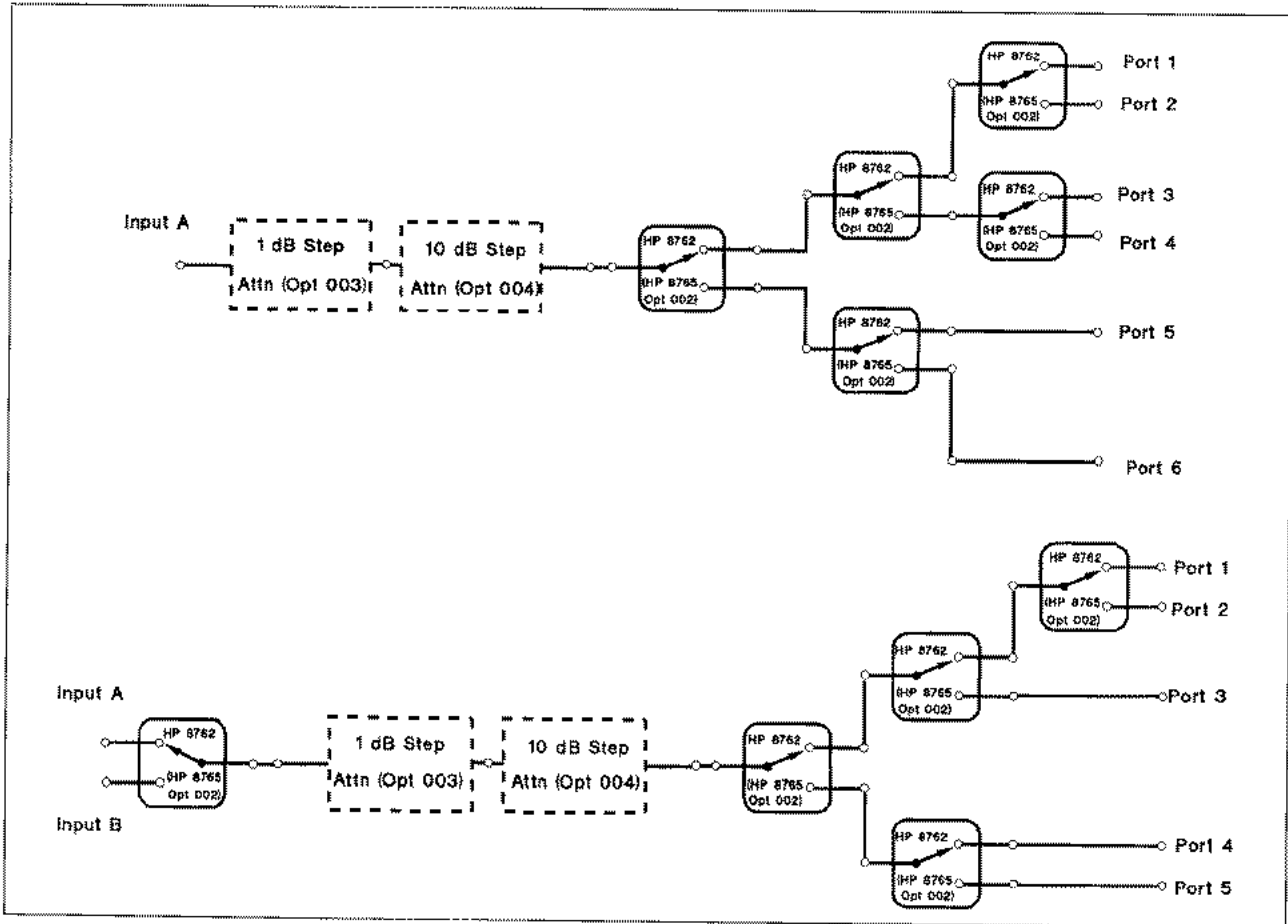

Block diagrams of the HP 70612A/C (top) and 70613A/C (bottom) interface modules

Ordering Information

HP 70612A 1x6 matrix, dc to 6.5 GHz

HP 70613A 2x5 matrix, dc to 6.5 GHz

HP 70612C 1x6 matrix, dc to 26.5 GHz

HP 70613C 2x5 matrix, dc to 26.5 GHz

Options for HP 70612A/C and 70613A/C

Option 002 delete switch terminations

Option 003 add 1 dB step attenuator

(price depends on frequency)

Option 004 add 10 dB step attenuator

(price depends on frequency)

Option 011 delete the CPU interface card (requires another module that contains the CPU card, such as the HP 70611A or the HP 70612/13)

Option W30 two additional years of return-to-HP warranty (3 years total)

System Integration

Custom Engineering

HP engineering and integration services are available to help meet your system goals. HP's expertise and experience ensure that your job will be done correctly, making best use of your firm's internal resources. These services are available through your HP sales representative.

Product enhancements

Hewlett-Packard can modify existing MMS products, tailoring their functionality to your needs. This cost-effective approach to system development can give you the highest performance while making use of designs that already exist. These product enhancements are offered with complete operating and service documentation, and the products are supported at HP service facilities worldwide.

Consulting

When you need functionality that is not currently available, consulting services through HP can assist in the development of modules or systems.

Hewlett-Packard

Software development

Save your firm the time and effort of having to learn instrument code. Experienced HP software and systems engineers can consult with you to develop your system software.

System integration

Partial or full system integration is available through HP. By out-sourcing this task, you can focus your attention on effective development and delivery of your products and services.

Custom Engineering



Tern Technology, Inc.

Overview

Since 1980, Tern Technology, Inc. (TTI) has been at the forefront in providing products and technical support to the RF/Microwave and ATE (Automatic Test Equipment) Industries. Our history of exceptional performance on technically challenging, quick-reaction programs is the cornerstone of our success. In 1992, the acquisition of a systems integration team focused on test and data acquisition enhanced the corporate capability.

Our product emphasis has been on switching systems with signal conditioning and processing capable of operation in an ATE environment. TTI's engineering expertise, sound work ethic and up-to-date manufacturing facility provide the basis for fully satisfying the most rigorous customer requirements with world class, quality products.

Tern Technology, Inc.

Customer satisfaction is our number one goal. We strive to provide the key technologies and support to lower both development and operation costs for our customers, ranging from complex avionics support to manufacturing quality assurance testing.

For more information, call or write:

Mr. Hank Podobinski
Tern Technology, Inc.
1747-22 Veterans Memorial Highway
Islandia, NY 11722

System Integration

Tern Technology, Inc. Model 890225A RF Receiver Module

Frequency range:
10 MHz to 40 GHz
(external mixer required for
signals above 18.5 GHz)

Amplitude range:
+30 to -130 dBm

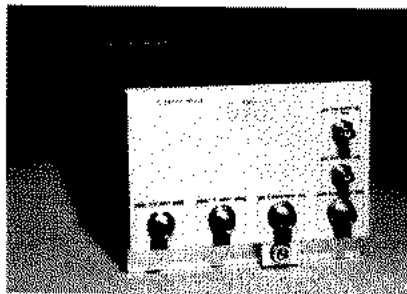

Overview

10 MHz to 40 GHz, +30 to -130 dBm receiver. Provides the capability to measure complex Electronic Warfare (EW) signals over the frequency range of 10 MHz to 40 GHz. Wide measurement range and sensitivity permit concurrent RF signal processing and spectral analysis to be performed. Includes a fundamental source 5.7 to 18.33 GHz. Four Slot MMS module.

Description

The RF Receiver Module was designed specifically for use within the MMS Mainframe and functions as the RF front-end, and operates while being controlled by the Hewlett-Packard (HP) Local Oscillator (LO) Module. This four (4) slot RF Receiver Module is deployed worldwide within the F-15E TISS Automatic Test Equipment (ATE) system.

The RF Receiver Module provides the ability to measure complex Electronic Warfare (EW) signals over the frequency range of 10 MHz to 40 GHz. Its wide measurement range (+30 dBm to -130 dBm) permits concurrent RF signal processing and spectrum analysis to be performed by the TISS ATE system. This extremely capable RF Receiver Module contains a fundamental 5.70 to 18.33 GHz source which is fully utilized by the TISS system.

Additional information regarding this product as it is associated with the program in which it has been designed, developed and manufactured will be provided gladly upon request.

Specifications

TII part number	10139370-102 (Model No.: TTI-890225A)
Frequency span	0 to 40 GHz
Inputs	RF In (Type-N), VLO In (Type-N), 300 MHz Cal In (BNC), S Band In (Type-N), Tune Span In (SMB), STALO In (SMA), 300 MHz LO In (SMB)
Outputs	SLO Out (Type-N), 321.4 MHz IF Out (SMA), 21.4 MHz IF 1 and 2 Out (SMB)
Power requirements	All power is supplied by the Modular Measurement System (MMS) mainframe
Temperature	Operating: 0° C to +55° C Storage: -40° C to +75° C
Relative humidity	5% to 95%
Warm-up time	Approximately twenty (20) minutes
Size	Height = 5.88 inches Width = 7.60 inches Length = 20.79 inches
Weight	Approximately eighteen (18) pounds

System Integration

Tern Technology, Inc.

Model 930219-101 Microwave Interface Unit

Overview

An integrated test system comprised of a complimentary MIM and a MOM, the MATS RFIU efficiently allows for a full complement of signal distribution, down conversion, fixed and variable delay, pulse detection and conditioning functions within.

Specifications	
Frequency range	10 MHz to 18 GHz
TTI part number	30000050-101
Model number	9302-
Frequency range	10 MHz to 18 GHz
Maximum input power	+30 dBm (path dependent)
RSS VSWR (In/out)	1.6:1 (typical)
Insertion loss	60 dB (microwave paths) 40 dB (UHF paths)
Functions	Composite of MIM & MOM
Isolation	Path function dependent

Control	IEEE-STD-488 bus MATE-STD-CIIL
Power requirements	MMS mainframe 200 watts maximum
Temperature	Operating: 0° C to 55° C Storage: -40° C to 75° C
Relative humidity	5% to 95%
Warm up time	10 minutes
Size	Height = 7.50 inches Width = 17.25 inches Length = 23.00 inches
Weight	≤ 60 pounds

Model 9302-M1 Microwave Output Module

Overview

10 MHz to 18 GHz provide signal conditioning and signal distribution along with the following functions

- fixed/variable pulsed RADAR delay emulation
- attenuation/signal gating combination and routing
- four slot MMS module

Specifications	
Frequency range	10 MHz to 18 GHz
Functions	Fixed / variable (with MIM) pulsed radar
Delay emulation attenuation/signal	Gating combination and routing
TTI part number	30000051-101
Model number	9302-M1
Maximum input power	+30 dBm (path dependent)
RSS VSWR (In/out)	1.6:1 (typical)
Insertion loss	path / function dependent
Isolation	60 dB (microwave paths) 40 dB (UHF paths)

Control	IEEE-STD-488 bus MATE-STD-CIIL
Power requirements	MMS mainframe 100 watts maximum
Temperature	Operating: 0° C to 55° C Storage: -40° C to 75° C
Relative humidity	5% to 95%
Warm up time	10 minutes
Size	Height = 5.85 inches Width = 7.60 inches Length = 20.79 inches
Weight	≤ 17.6 pounds

Tern Technology, Inc. Model 9286 Phase Noise Module

<i>Offset</i>	<i>Noise Floor</i>
100 Hz	-85 dBc/Hz
1 KHz	-107 dBc/Hz
10 KHz	-124 dBc/Hz
30 KHz	-124 dBc/Hz
100 KHz	-127 dBc/Hz
300 KHz	-135 dBc/Hz

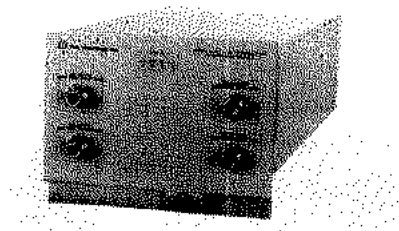

Overview

Microwave (X-band) and VHF frequency module to measure both absolute phase noise and AM noise (Opt 002) to -124 dBc/Hz at 10 KHz offset from carrier. Four slot MMS module.

Description

The TTI Model 9286 Phase Noise Module was primarily developed to assist Automatic Test Equipment (ATE) system prime contractors in the performance of absolute phase noise measurements. This four (4) slot wide Modular Measurement System (MMS) plug-in unit is able to supplement the capability provided by other station assets, and eliminates the need to configure the ATE system with an expensive and large phase noise analyzer approach.

The Model 9286 Phase Noise Module operates over the Modular System Interface Bus (MSIB). AC power and remote programming (via GPIB) is provided within the MMS system. This Phase Noise Module is provided with two (2) inputs corresponding to the two (2) operational frequency ranges, the first in the microwave range and the second in the VHF range. The microwave operating range is preset at TTI by selection of the internal low noise source.

Additional information regarding product options and further selections in sensitivity will be provided gladly upon request, including information about standalone phase noise conditioner units with a varied selection of sensitivity ranges. These specifications are achievable when a Hewlett-Packard HP 71209A Spectrum Analyzer, equipped with an HP 70900B Local Oscillator (LO) Module, is used to perform the measurement.

Specifications

TTI part number	9286
Frequency range	Microwave (input) 9.33 to 9.50 GHz and 9.70 to 9.87 GHz, VHF (input) 100 to 270 MHz
Temperature	Operating: 0° C to +55° C Storage: -40° C to +75° C
Relative humidity	5% to 95%
Warm-up time	Approximately thirty (30) minutes
Microwave noise floor	
<i>Offset</i>	<i>Noise Floor</i>
<input type="checkbox"/> 100 KHz	-78 dBc/Hz
<input type="checkbox"/> 1 KHz	-97 dBc/Hz
<input type="checkbox"/> 10 KHz	-102 dBc/Hz
<input type="checkbox"/> 30 KHz	-109 dBc/Hz
<input type="checkbox"/> 100 KHz	-120 dBc/Hz
<input type="checkbox"/> 300 KHz	-130 dBc/Hz

Options

Opt 001 - Extended sensitivity

Opt 002 - AM noise processing capability for either CW or pulsed signals (standard sensitivities = -120 dBc/Hz at offsets < 400 Hz)

Functions

Downconverts the Unit Under Test (UUT) signal to be measured, contains the signal conditioning necessary to extend sensitivity of standard spectrum analyzers, and enables highly sensitive phase noise measurements to be performed.

Power requirements

All power is supplied by the Modular Measurement System (MMS) mainframe

Size
Height = 5.88 inches
Width = 7.60 inches
Length = 19.58 inches

Weight
Approximately seventeen (17) pounds

System Integration

Tern Technology, Inc. Model 9302-M2 Microwave Input Module

Functions

- *Multiple signal routing*
- *Pulse detection and down conversion*
- *High gain, low noise figure measurement path (UHF)*
- *Adjunct to MOM for radar signal*
- *Emulation*

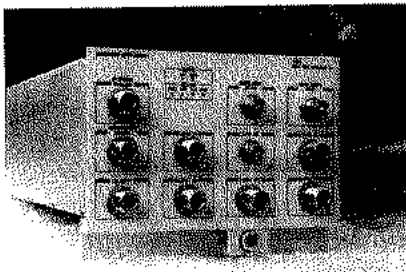

Overview

10 MHz to 18 GHz provides multiple signal routing with signal conditioning for measurement.

Functions provided:

- pulse detection and down conversion
- high gain, low noise figure measurement paths (UHF)
- multiple signal routing
- adjunct to 9302-m1 for RADAR emulation (option)
- four slot MMS module.

Specifications

TTI part number	30000052-101
Model number	9302-M2
Frequency range	10 MHz to 18 GHz
Maximum input power	+30 dBm (path dependent)
RSS VSWR (In/out)	1.6:1 (typical)
Insertion loss	Path / function dependent
Isolation	60 dB (microwave paths) 40 dB (UHF paths)
Control	IEEE-STD-488 bus MATE-STD-CIIL
Power requirements	MMS mainframe 100 watts maximum
Temperature	Operating: 0° C to 55° C Storage: -40° C to 75° C
Relative humidity	5% to 95%
Warm up time	10 minutes
Size	Height = 5.85 inches Width = 7.60 inches Length = 20.79 inches
Weight	≤ 17.6 pounds

Model 9403A X-Band Linear Amplifier

Maximum input power:
+20 dBm (2.4 to 20 GHz)
No damage
Insertion gain: >25 dB

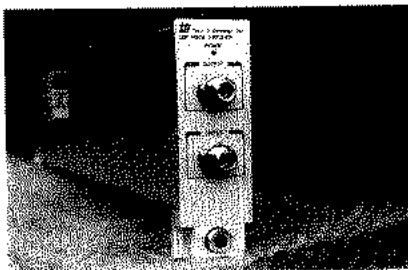

Overview

50 dB gain provided from 10 MHz to 18 GHz with virtually no contribution to the phase noise of the amplified signal. One slot MMS module.

Components

MMS Processor

Description

Low noise and low harmonic output amplifier with a saturated power output of 26.5 to 29 dBm (@ +5 dBm input). Units are characterized to insure extremely low additive phase noise and AM noise contribution.

Specifications

TTI part number	30000141-101
Model number	9403A
Frequency range	8.2 to 11.5 GHz
Maximum VSWR (In/out)	≤ 2.0:1
Reverse isolation	± 40 dB
Functions	Band limited amplification Low noise Low harmonics
Power requirements	MMS mainframe 100 watts maximum
Temperature	Operating: 0° C to 55° C Storage: -40° C to 75° C
Relative humidity	5% to 95%
Warm up time	20 minutes
Size	Height = 5.85 inches Width = 1.88 inches Length = 20.79 inches
Weight	≤ 6.5 pounds

System Integration

Tern Technology, Inc. Modular Measurement System Components

TTI's extensive design experience within the Modular Measurement System architecture enables us to offer standard and tailored designs including MMS components as follows:

Power supplies

MMS Plug-in Modules are provided with 40 KHz AC power via the HP 70000 Mainframe. This regulated source permits the user to develop very high efficiency power supplies within a module. TTI has designed and manufactured many power supplies using this AC source. Our supplies are used in stringent RF/Microwave environments, where power supply noise can degrade performance.

We offer standard and custom supplies for MMS modules.

MSIB interface

TTI is very familiar with the MSIB interface, having designed modules using the GPIB interface internal to the MMS, and modules that use the MSIB bus. We offer designs and services to meet your MSIB needs.

VXI/VME designs and typical applications

Our previous experience has required designs that are compatible with the VXI architecture. As a result, TTI can provide modular RF/Microwave equipment using the VXI system as a host.

Integration services and support

TISD specializes in Integration Engineering with a particular focus on Test and Data Acquisition Technology. The complementary nature of our skills to our customers provides for a synergistic relationship to increase our customer's ability to leverage business to their advantage. The systems approach to solving customer problems is the only means to produce successfully integrated products into the customer environment which are fully compliant with all requirements. To accomplish this, we have established relationships with many industry leaders (such as HP, National Instruments, and TYX).

TISD can develop complete systems or subsystems for testing. Our test engineering services include:

- test programs (TPs or TPSs)
- software re-engineering
- requirements documents (TRDs)
- test system utility development
- compiler and test executive development and maintenance
- software post processor development
- database management design
- life cycle cost analysis
- fault list generation and integration aids
- configuration control, status and audit
- software development and migration
- system improvement/life cycle extensions
- system or subsystem integration test
- testability analysis
- calibration verification utilities

Our experience includes an extensive set of Military and Commercial standards including IEEE 488, ATLAS, Ada, VXIbus, MMS consortium, DoD Std 2167A, DoD Std 2168, Mil Std 1519, Mil Std 2077, Mil Std 1345A, Mil Std 483, SMART, MATE, CASS, SCPI, SQL, Labview and VEEtest, to name a few.

Over the last decade, microprocessor technology has produced advanced tools and power in a cost effective, down sized package that is available for almost any application. However, the poor integration of these resources and tools within a systems framework (tied to vendor independent open standards and customer operational needs) remain an impediment to achieving production/operational efficiencies. The knowledge and discipline to effectively and methodically incorporate this technology is what Integration Engineering is, and what TISD has to offer.

TISD is committed to the implementation of these technologies via Open Systems Solutions to the maximum extent possible.

Tern Technology, Inc.
35 N. Central, Suite 501
Clayton, MO 63105
(314) 727-1337
Contact: Michael Rutledge

System Integration

Custom Engineering
Remote Operation Software

Hamilton Software
iPanels

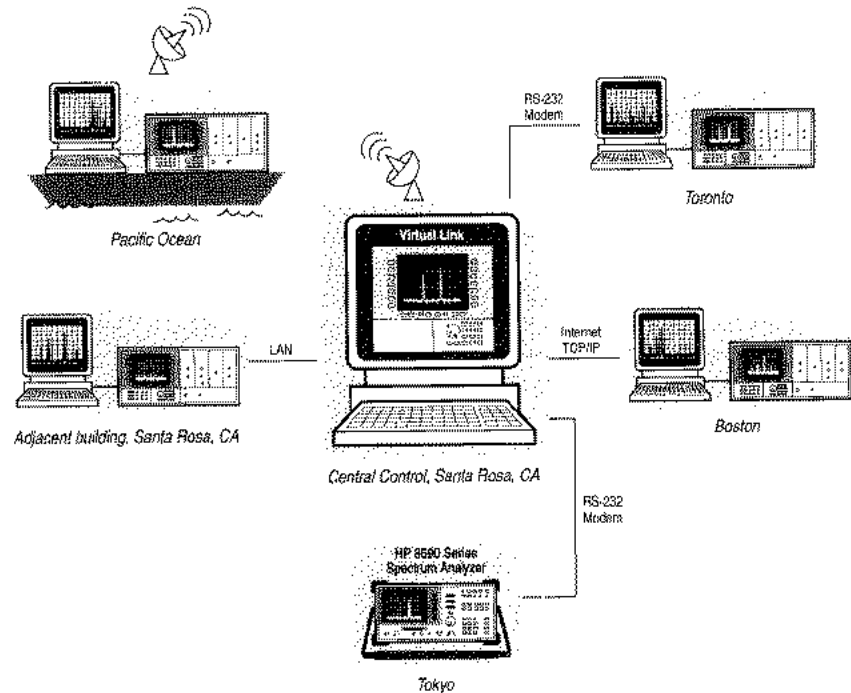

iPanels for Windows[®] NT provides remote operation and other powerful capabilities for the Modular Measurement System.

iPanels is used in conjunction with the HP 70207B, a PC ISA interface card and software that allows a PC and the lower-cost HP 70001A mainframe to replace the HP 70004A display/mainframe. iPanels also works with the HP 70004A and adds the same capabilities.

Remote operation of MMS

A PC with the HP 70207B is connected locally by MSIB to the MMS system. The local PC provides full control and display capability for the system. The remote PC with iPanels can communicate with the local PC via a LAN, conventional modem, wireless modem, or the Internet (TCP/IP). iPanels creates a virtual front-panel interface on the monitor of the remote PC.

The virtual panel looks and functions like the HP 70004A display. By simply clicking a mouse on the virtual controls, you can operate the MMS system and see measurement results on the remote PC. When connected by LAN, operation is real-time. Operation via modem is very fast when the latency of the connection is considered.

Remote control of multiple systems and standalone instruments

Using a single PC with iPanels, an engineer at one location can control up to 31 different MMS modules, systems and standalone instruments located around the globe. They can be connected via LAN, modem, or the Internet. Each MMS system must have a locally-connected PC with the HP 70207B.

Control of non-MMS devices

An HP 8590 series spectrum analyzer with RS-232 interface may also be linked to the remote PC by LAN, modem or Internet and operated as though it were an MMS module. A local PC is not required. When you select the spectrum analyzer from the remote PC, the software changes the virtual HP 70004A front panel to an HP 8590 panel. In the future, additional GP-IB instruments and VXI modules will be similarly integrated with the MMS environment and remotely operated from the Windows[®] interface.

System Integration

Custom Engineering

Remote Operation Software

Hamilton Software

iPanels

Additional capabilities

The Windows interface provides capabilities never before available in a commercial software product:

- direct interaction with Windows applications
- output to Windows-supported printers and plotters
- unattended operation
- data logging and storage
- keystroke recording and playback

While performing measurements remotely or locally, you can copy the virtual instrument screen and paste it into any Windows word processor or graphics application for records and reports. You may also export measurement data to a spreadsheet like Excel[®] for analysis.

Test results can also be output to any printer or plotter driven by your PC. You can program your PC to perform automatic measurements at any time of the day or night, over any time period. Data obtained from manual or automatic operation may be stored and logged in a data file. The size of the data file is limited only by the storage capacity of your computer.

To help you repeat a test procedure exactly, the software records any sequence of MMS keystrokes and plays it back whenever you wish.

Custom MMS module development

Hamilton Software develops custom MMS modules by connecting RS-232, GP-IB and VXI instruments and interfacing PC-based ATE cards to iPanels. Digitizers, counters or any other custom PC boards can be converted to function as MMS modules quickly at low cost. Modules with low production volume can be incorporated and manufactured cost-effectively.

PC/MMS hardware integration

A unique PC-ISA card and software allow remote control of a Modular Measurement System. Non-MMS modules can easily be connected to the MMS to provide custom solutions to meet a specific need or purpose, quickly and cost-effectively. Your existing products can be a part of the MMS family in a fraction of the time and cost it takes to develop a plug-in module.

Contact Hamilton Software for custom requirements for your Modular Measurement System.

Ordering Information

Hamilton Software, Inc.
2270 Northpoint Parkway
Santa Rosa, CA 95407
Tel: (800) 704-0085; (707) 542-2700
FAX: (707) 542-3443
email: hsi@hamsoft.com

Hamilton Software offers a full range of software and firmware services for MMS module developers and end users as well as custom software engineering for non-MMS applications. See our company overview elsewhere in this catalog or contact us directly at the address shown.

Custom software

Programmable microwave switch drawers

Microwave fixturing

Production fixturing

- robotics
- pneumatic
- manual fixturing

Custom ATE services

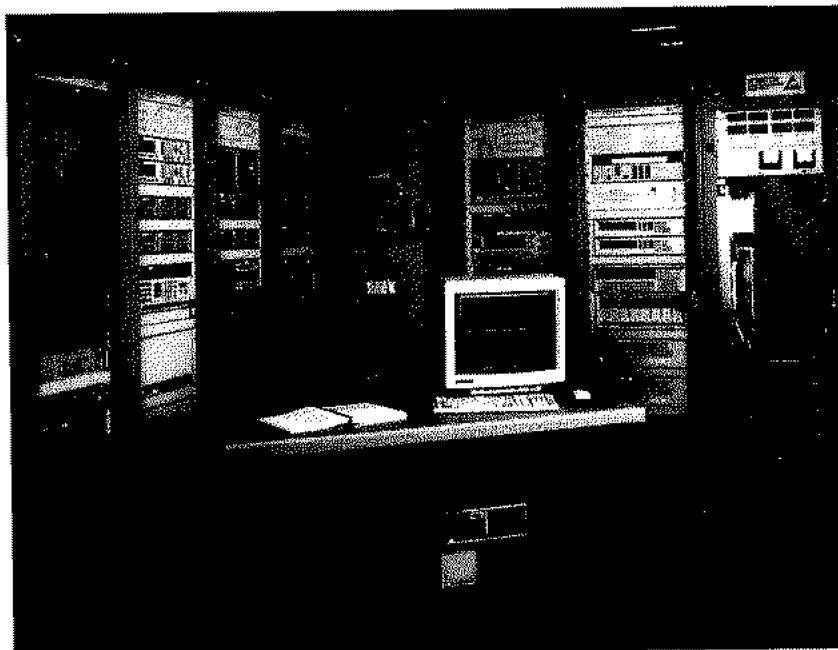

Symtx

One of Hewlett-Packard's Channel Partners, Symtx has built a reputation as a quick response, custom test system integrator, known for our "FasTest Service." To help you meet your schedule, all of our test systems are done on a fixed schedule and budget, with quick delivery, in as little as a few weeks.

Symtx's microwave capabilities include:

Programmable microwave switch drawers

Symtx can create customized microwave switch drawers to provide you measurement flexibility.

Microwave measurement techniques

We are experts in microwave measurements up to 40 GHz, including coaxial transmission lines and waveguide.

Symtx's general test system development capabilities include:

Detailed requirement specs

We develop detailed specification of the operations and measurements required to fully characterize and qualify your product, including equipment and measurement techniques, ergonomic issues, networking, data storage, communication with other systems, and any other special requirements.

Custom hardware development

We can design and document any special hardware and fixturing you need to interface with your product, including custom racks, special microwave switching, and user interface issues. The hardware is packaged to meet your requirements using VXI modules, rack mounted instruments, or custom packaging.

Software development

We will design and document the system self-test, calibration, or application software required to perform product testing and characterization. This can be provided under your choice of environments, including UNIX, DOS/Windows, real-time operating systems (such as Lynx), or embedded (firmware). The language used for implementation is similarly yours to select, with most projects developed in C/C++, HP VEE, or Visual Basic.



Exclusive *FasTest* Service means that Symtx can supply a custom turnkey test system — including custom hardware, software, and fixturing — in just a few weeks for extremely time-critical projects.

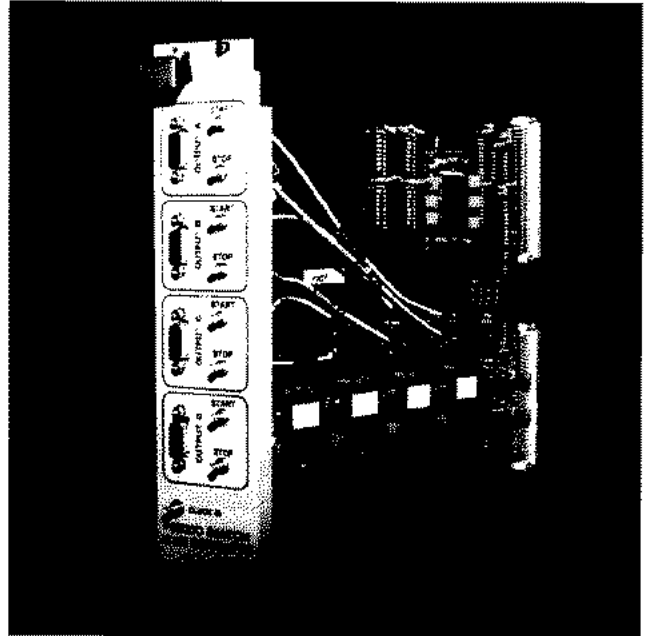

Fixturing

We can develop the custom interfacing required to connect a measurement system to your product, including: on-wafer probing, pneumatic fixturing, custom interface boards, or special mechanical interfaces. We can even develop automatic (robotic) controls for loading or adjusting your product.

Symtx is headquartered in Austin, Texas, with an office in San Jose, California. We have been in business since 1981 and have been a Hewlett-Packard Channel Partner since the program's inception. For more information about Symtx or a list of customer references, please give us a call.

Our engineering department has the expertise to get your product to market on time. Each project is backed with a full warranty and complete follow-up support.

When you work with us, we take care of you. Every phase of the project is scheduled in detail before we start. It's updated and reviewed on the way. So we keep you on schedule. We can do the entire system, or assist you in any phase of your project.

For critical deadlines, ask us about our *FasTest* Service — we can turn around an entire project in a matter of weeks when your customer just can't wait. For more information or a free info packet, please give us a call at **(800) 560-TEST (8378)**.

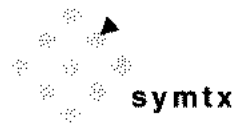

For more information
Contact Sales Manager at:
Symtx
1301 Capital of Texas Hwy.
Suite #C 200
Austin, TX 78746
Tel: (800) 560-TEST (8378)
(512) 328-7799
Fax: (512) 328-7778
E-mail: FasTest@symtx.com

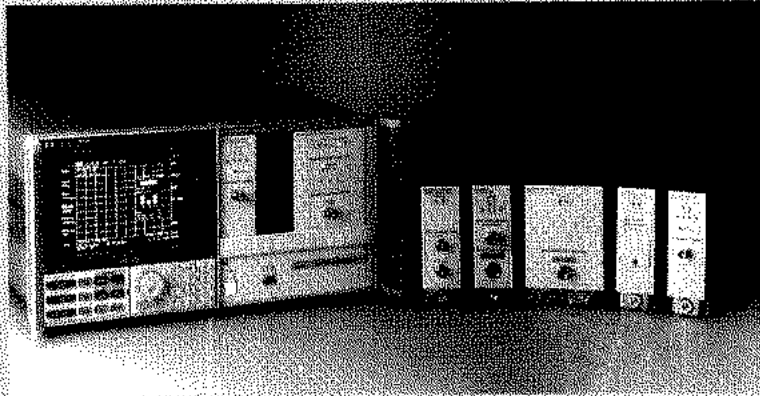

Configure modules for unique system applications.

Add system accessories.

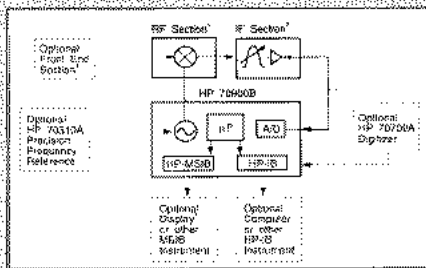
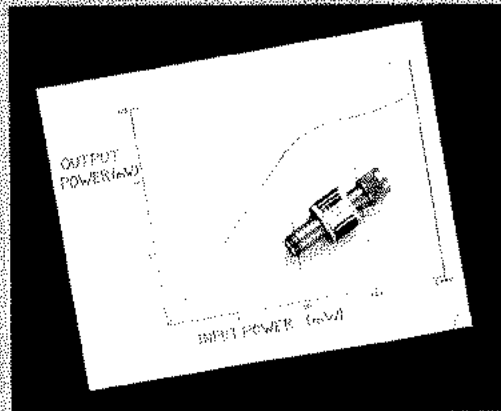

Block diagrams

Section Contents

135 System Building Blocks

- 136 System Mainframe
- 137 PC Display for MMS
- 138 System Displays
- 141 Tracking Generators
- 143 Precision Frequency Reference
- 145 MATE Module
- 146 Microwave Transition Analyzer
- 148 Local Oscillator
- 151 IF Sections
- 154 RF Sections
- 159 External Mixer Interface Module

161 Computers and Software

- 161 Visual Engineering Environment

164 Accessories

- 165 System Accessories
- 165 Cables
- 166 General Accessories

System Building Blocks

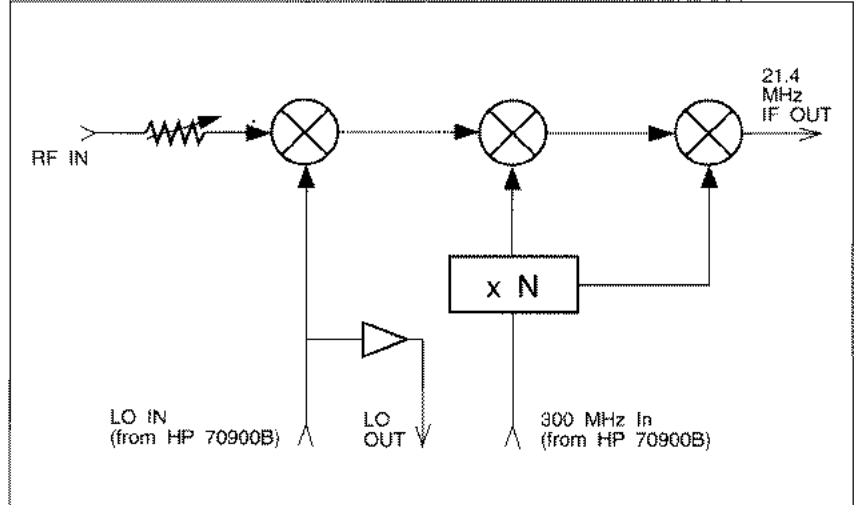

This section describes modules that are often used for more than one task. These modules can form the basis of a dedicated system for individual applications, such as those applications described in the Configuration Examples.

General functionality, feature set, block diagrams, and input and output characteristics are given here for each module.

System components, such as mainframes and displays, and accessories for modules and instruments are also included.

System Building Blocks

System Mainframe

HP 70001A

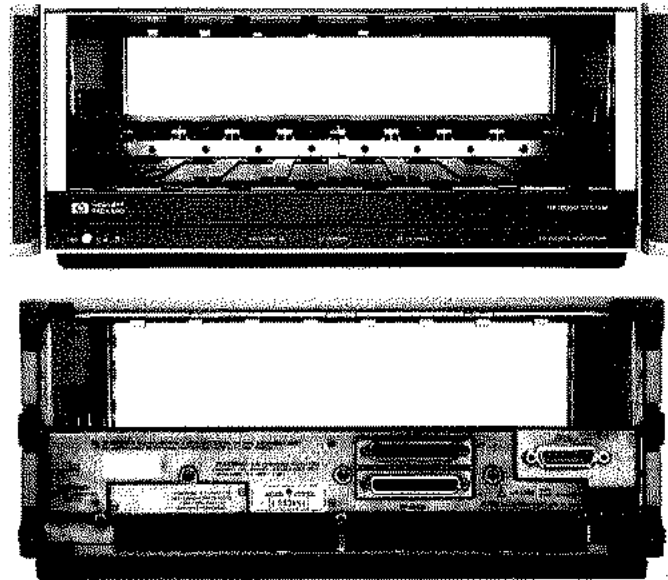

The HP 70001A system mainframe provides the structural environment for MMS plug-in modules as well as cooling, power, and digital communication interface buses (MSIB and HP-IB). It has eight slots available for single- or multiple-slot modules. It is compatible with standard EIA racks, and its integral bails and handles make bench top use easier.

The modular system interface bus (MSIB) provides high speed digital communication between MMS instruments, modules, and displays connected in the same system. The MSIB allows simultaneous communication between all modules on the bus. The Hewlett-Packard interface bus (HP-IB) is used to provide computer control and communication between MMS instruments and other HP-IB instruments, including VXIbus products.

The mainframe has good EMC performance and rugged structural design, making it suitable for sensitive measurements in tough industrial environments. System configuration is easy. Simply sliding a module into place automatically connects it to the power, digital interface, and forced-air cooling supplied by the mainframe. The flexibility, reliability, and performance of the HP 70001A system mainframe make it the ideal foundation for the modular measurement system.

General Characteristics

Dimensions	177 mm high, 425.4 mm wide, 526 mm long (6.97 in, 16.75 in, 20.7 in)
Weight	14.5 kg (32 lb)
Power requirements	
AC mains	100, 102, 220, and 240 V ac ($\pm 10\%$)
Frequency	47-66 Hz and optional 400 Hz (Opt. 400 and 401; 100 and 120 V ac only)
Max power	360 W, 600 VA
Max power delivered to the modules	200 W/mainframe 100 W/connector
Environmental	
Temperature	Operational, 0° to +55° C Storage, -40° to +75° C
Humidity	Operational, 0 to 95 % relative humidity at 45° C
EMC	Conducted and radiated interference is in compliance with CISPR pub 11, FTZ 526/1979, and MIL-STD 461B, RE02/part 7.

Ordering Information

HP 70001A mainframe

- Option 010** rack slide kit (part no. 5062-0781)
- Option 400** 400 Hz power line operation
- Option 908** rack flange kit without handles attached (part no. 5062-3978)
- Option 910** extra user's manual
- Option 913** rack flange kit with handles attached (part no. 5062-4072)
- Option 915** service manual set

System Building Blocks

PC Display for MMS

HP 70207B

Full capability of an MMS display in a PC window

Easy operation using mouse

Multi-tasking and software synergy

Printer/plotter dumps to any Microsoft Windows® device

Faster throughput than previous displays

Compatible with all MMS instruments—no firmware upgrades needed

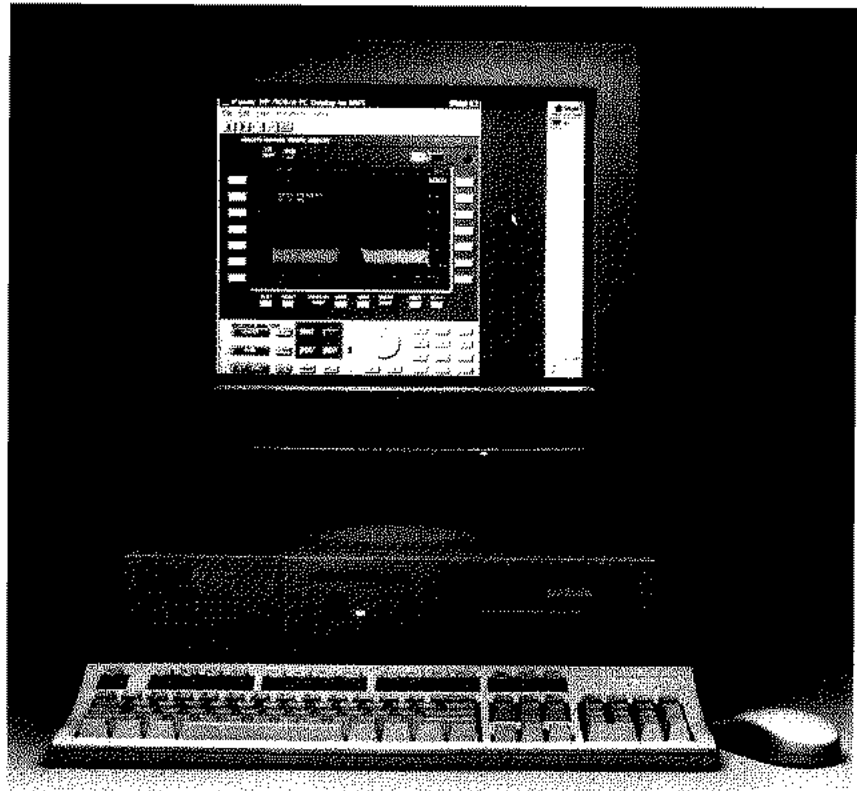

HP 70207B
Opt. E05

The HP 70207B PC display for MMS provides complete manual control of any MMS asset from a local PC. The product consists of an MSIB interface board, software, and y-cable. It implements the display protocol as defined in the MMS specifications issued by the MMS consortium. This ensures operation with any MMS instrument that supports a manual interface. No firmware upgrades are required to use the PC display with an MMS instrument, regardless of when the instrument was produced.

Enhanced test system operation
Taking advantage of Windows NT® multi-tasking capabilities, a PC controller with test system software and the PC display can provide you with continuous visual feedback about the test process. Direct instrument control from the PC controller simplifies system troubleshooting.

Simplified report generation
Exporting measurement results to other applications for report genera-

tion simply requires using Windows cut-and-paste features. Measurement images are transferred directly into your word processing program. The PC display software also works through the Windows environment to enable you to use printer any hardware and drivers installed in the system, including color printers.

The PC display is standard with all HP 71000P series spectrum analyzer and receiver systems.

Additional Information **Product Overviews**

HP 70207B PC Display for MMS
part no. 5965-4795E

Modular Spectrum Analyzers with PC Displays
part no. 5965-5791E

Ordering Information

HP 70207B PC display for MMS
Call the factory for pricing of options that include an HP Vectra PC.

Option E05 PC Display for MMS, HP Vectra Pentium PC, 17-inch Monitor, Windows NT, Keyboard, Mouse, User's Guide and MS-IB cable

Option E06 PC Display for MMS, HP Vectra Pentium PC, 17-inch Monitor, Windows NT, Keyboard, Mouse, User's Guide, MS-IB cable, HP-IB board and HP BASIC programming language

Option E07 PC Display for MMS, HP Vectra Pentium PC, 17-inch Monitor, Windows NT, Keyboard, Mouse, User's Guide, MS-IB cable, HP-IB board, HP BASIC and HP-VEE programming languages

Standard systems with PC display for MSS

HP 71100P RF spectrum analyzer

HP 71210P 22 GHz spectrum analyzer

HP 71209P 26.5 GHz spectrum analyzer

HP 71910P wide band receiver

System Building Blocks

System Displays

HP 70205A

Modular measurement system displays

Several displays are available for use in the modular measurement system. The HP 70205A provides a menu-driven human interface in a compact 3-slot module package.

The HP 70004A provides an improved human interface on a 7.5-inch color display, plus a mainframe capable of holding four 1-slot modules. The HP 70207B provides a display on a PC. All displays provide the manual interface to the modular measurement system, which can have up to 31 MMS instruments and up to 255 MMS modules. An address map shows the configuration information.

These high resolution graphic displays show measurement results, including trace information, text, and markers. Softkeys organized in a menu structure establish an interactive front panel for the modular instrument. Results from up to four independent measurement systems can be shown and simultaneously updated on a single display, and one display can be used to control multiple systems. Without a display in the system, a computer must be used to control the instruments. The display can be separated from the MMS instruments by up to 1.0 kilometers of MSIB cable for use as a remote manual interface.

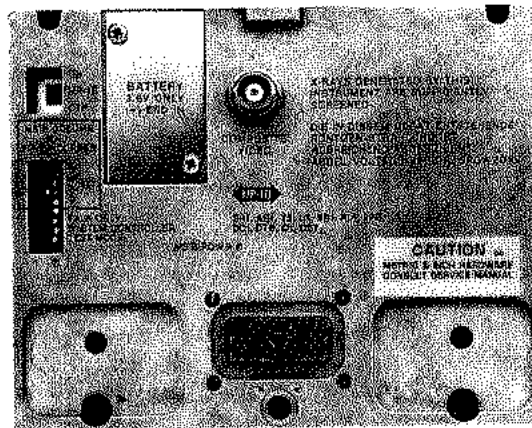
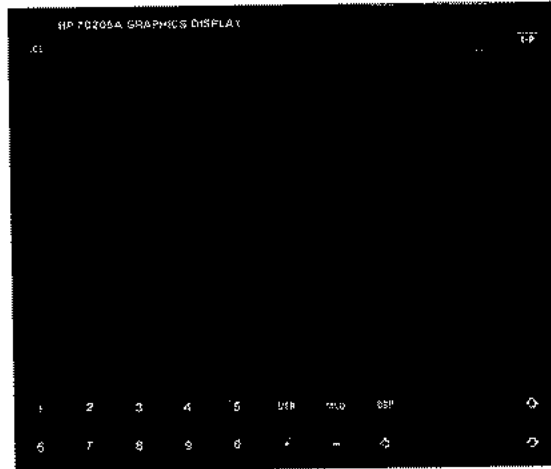

HP 70205A display

The HP 70205A graphic display is a 3-slot module that provides a menu driven human interface for the HP 70000 modular measurement system. The HP 70205A is ideally suited for applications in which space, size, and weight requirements are stringent. It is small, yet gives you full control of the modular instruments in your system.

Specifications for the HP 70205A are included with the HP 70004A.

System Building Blocks

System Displays

HP 70004A

HP 70004A color display and mainframe

The HP 70004A display has a full color CRT, a removable custom hardkey panel, a key to aid in selecting the MMS instrument to be controlled, and several advanced firmware features. The HP 70004A has a mainframe section capable of holding up to four 1-slot MMS modules.

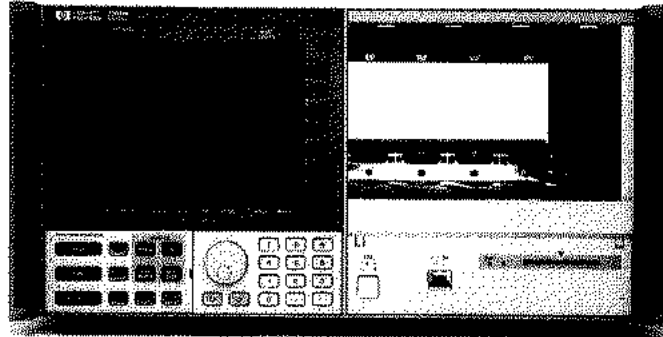

Color display

The color display can show up to sixteen colors at once. An advanced color editor allows you to change the color of various display elements by choosing from a palette of 4,096 colors. The color of display elements, such as traces, graticule lines, and background, can be changed to suit your needs. If you are color blind or need to use special protective goggles for work with lasers, you can select built-in palettes with colors that are useful for you. Also, a monochrome mode (ten shades of green) is available. This selection is convenient if you are using a remote monochrome monitor to view the display.

Mainframe

Four module slots can be used to house a modular instrument or used with an HP 70001A eight-slot system mainframe to expand the system. The HP 70004A supplies the power and cooling for MMS instrument modules.

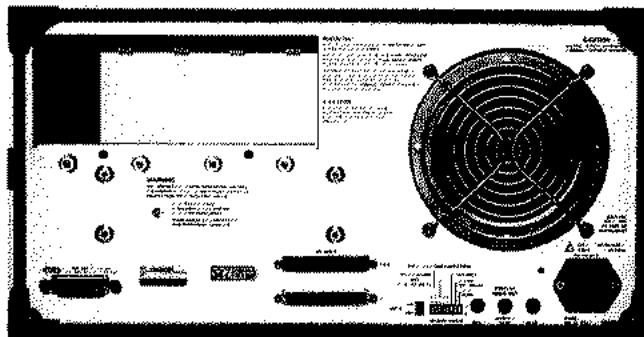

Multiple instrument control

Up to four modular instruments can be shown on the display simultaneously. The display keyboard (softkeys and hardkey panel) controls one instrument at a time. The INSTR key lets you pass control from one instrument to another with a single keystroke.

Printer/buffered plotter dump

Like the HP 70205A, the HP 70004A sends displayed graphics to an HP-IB printer or plotter.

Custom hardkey panel

The HP 70004A has a front panel keypad that can accommodate a custom hardkey panel for quick and easy access to the most frequently used functions of your modular instrument. Custom hardkey panels are provided with the HP 70000 spectrum analyzers, the microwave transition analyzer, and the optical spectrum analyzer.

System Building Blocks

System Displays

HP 70004A/70205A

Features	HP 70205A	HP 70004A
High-resolution (1024x400) graphics display	Yes	Yes
Display size	5-in diagonal	7.5-in diagonal
Color display	No	Yes (16 colors)
Size	3-slot module	EIA rack width ¹
INSTR key	No	Yes
Custom hardkey panel	No	Yes
Plot/print hardkeys	No (softkeys only)	Yes
HP-IB Printer support	HP ThinkJet	HP PaintJet, HP ThinkJet
HP-IB Plotter support	HPGL	HPGL (buffered)
AC power	Supplied by mainframe	800 VA
Memory card support	No	Yes ²
External monitor output	Composite video	R, G, B; composite sync or green
Horizontal sweep rate	24.5 kHz	25.5 kHz

General Characteristics

External monitor output³

Composite video (HP 70205A)

- Connector BNC female, rear panel
- Horizontal sweep rate 24.5 kHz \pm 1%
Signal level into 75 Ω load= 1 V p-p \pm 10%,
60 Hz \pm 1% refresh rate, 25 MHz bandwidth

R, G, B color (HP 70004A)

- Connectors (R, G, B): RCA phono, rear panel (horizontal sync. on green)
- Horizontal sweep rate 25.5 kHz
Signal level into 75 Ω load= 1 V p-p \pm 10%,
60 Hz \pm 1% refresh rate, 25 MHz bandwidth

Dimensions

HP 70205A	3-slot module
HP 70004A	222 mm high, 425.4 mm wide, 526 mm long (8.74", 16.75", 20.7")

Weight

HP 70205A	5.1 kg (11.2 lb)
HP 70004A	20 kg (44 lb)

Power requirements (HP 70004A only)

AC mains	100, 102, 220, and 240 V ac (\pm 10%)
Frequency	47 to 66 Hz and 400 Hz
Max power, HP 70004A	260 W; delivers 25 W/slot

Environmental

Temperature	Operational, 0° to +55° C Storage, -40° to +75° C
Humidity	Operational 0 to 95% relative humidity at 45° C

EMC

Conducted and radiated interference is in compliance with CISPR pub 11, FTZ 526/1979, and MIL-STD 461B, RE02/part7

Ordering Information

HP 70004A color display and mainframe

Option 810 rack mount slide kit (part no. 5062-7086)

Option 908 rack flange kit without handles (part no. 5062-3979)

Option 910 extra user's manual set

Option 913 rack flange kit with handles (part no. 5062-4073)

Option 915 service manual set

HP 70205A graphics display

Option 910 extra user's manual

Option 915 service manual set

See page 137 for information on the HP 70207B PC display for MMS.

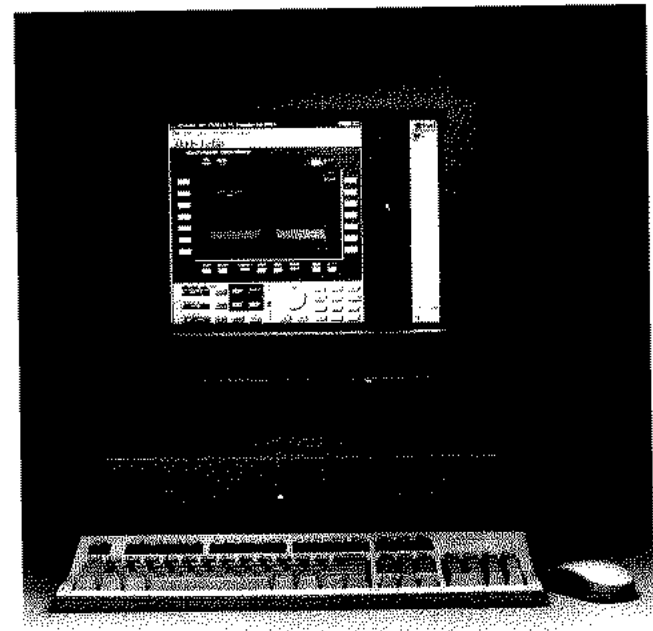

HP 70207B
Opt. E05

- ¹ The HP 70004A also contains four module slots for modular instruments.
- ² The HP 70004A provides access to its internal memory card or an HP-IB disk drive by a module that has mass storage driver capability such as an HP 70900B local oscillator.
- ³ See accessory pages for compatible large-screen monitors.

System Building Blocks

Tracking Generators

HP 70300A/70301A

Use in scalar and spectrum analyzers

Use as RF and microwave sources

HP 70300A is 20 Hz to 2.9 GHz

HP 70301A is 2.7 GHz to 18 GHz

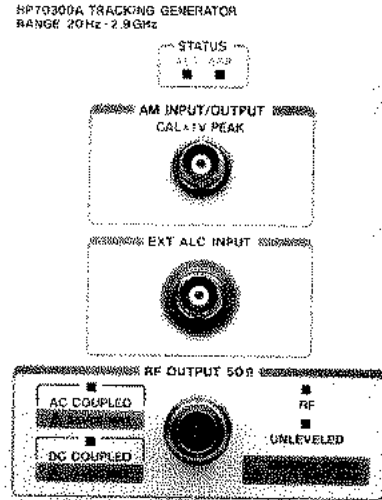
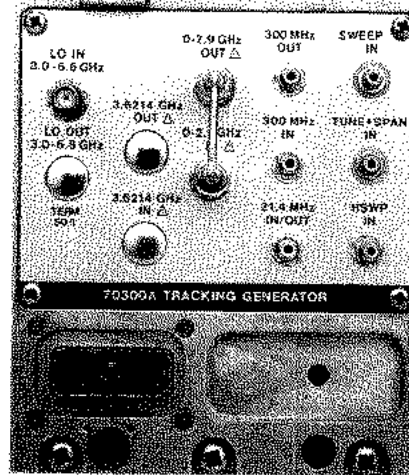

Component test system

Two tracking generators combine with HP 70000 spectrum analyzers to create component test systems that cover RF to lightwave. Use them with the HP 71100C/P, the HP 71209A/P, or the HP 71210C/P spectrum analyzers for high dynamic range scalar network analysis and for signal analysis measurements.

Characterize the frequency response of optical components using the HP 70300A with the HP 71401C lightwave signal analyzer or use both tracking generators with the HP 71400C lightwave signal analyzer.

Together the tracking generators cover from 20 Hz to 18 GHz. Both tracking generators are compatible with the HP 70871A scalar personality.

Offset tracking

Make real-time frequency response or gain/loss measurements on mixers, up/down converters, and other frequency-translated devices. Combine the HP 70300A with another HP 70900B LO module to get an independent source that tracks the spectrum analyzer with an offset up to 2.9 GHz from the analyzer input.

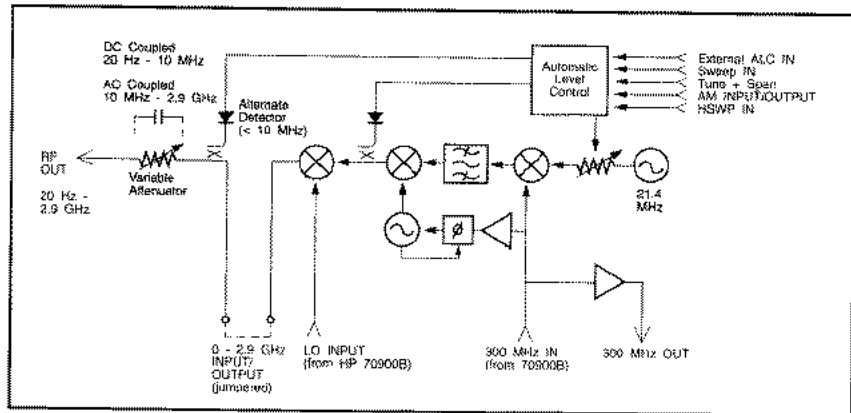

HP 70300A block diagram

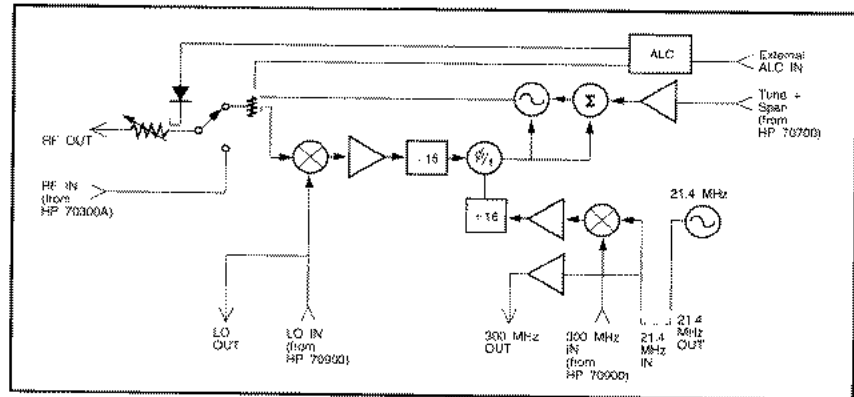

HP 70301A block diagram

System Building Blocks

Tracking Generators

HP 70300A/70301A

RF and microwave sources

Create an RF or microwave source to produce continuous wave (CW) or swept signals. You can use the HP 70300A with the HP 70900B local oscillator for a 20 Hz to 2.9 GHz source (20 Hz to 10 MHz available with alternate detector mode). You can also use the HP 70301A and 70900B for a 2.7 to 18 GHz source. Or use both tracking generators for a 20 Hz to 18 GHz source. These sources are fully programmable with adjustable output power.

The HP 70300A RF tracking generator can be amplitude-modulated and has power sweep capability.

General characteristics

Refer to *Instruments section for module and system specifications and ordering information.*

Installation and Verification Manual HP 70300A

Part number 70300A-90096

HP 70301A

Part number 70301-90003

Operation Manual

HP 70300A and 70301A

Literature number 5958-7011

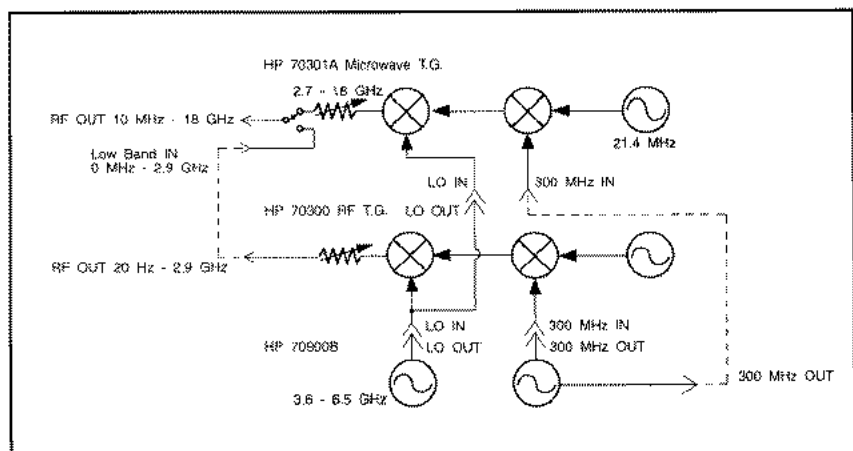
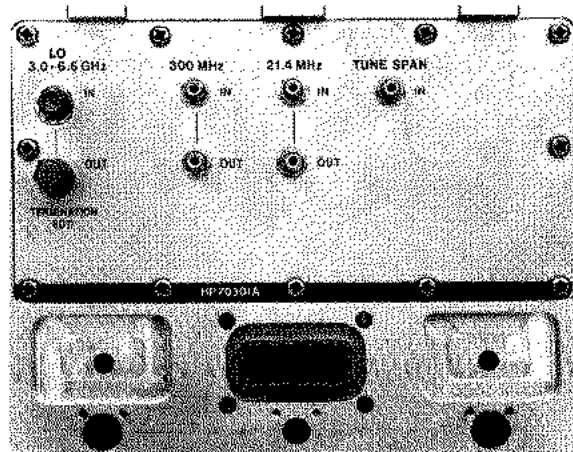
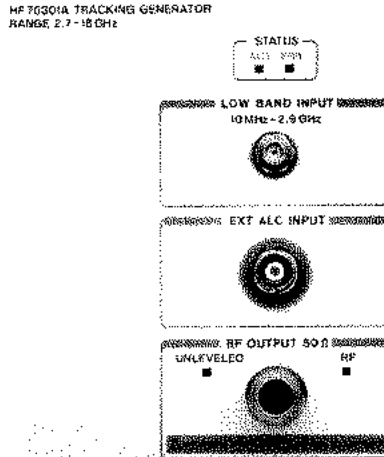

Dual tracking generator source

System Building Blocks

Precision Frequency Reference

HP 70310A

The HP 70310A precision frequency reference, a 1-slot plug-in module for the HP 70001A mainframe, provides precision reference signals for use by HP 70000 systems and other instruments. System frequency accuracy is enhanced because the 10 MHz and 100 MHz reference signals provided by the HP 70310A are phase locked to an internal ovenized oscillator, resulting in excellent stability over both time and temperature. By adding the HP 70310A, the reference aging rate of HP 70000 modular spectrum analyzers is improved to 1×10^{-7} /year from 3×10^{-6} /year, and temperature stability is improved to 7×10^{-9} from 1×10^{-5} over 0° to 55° C. A power pack accessory included with the module provides standby power for the oven when the mainframe is turned off.

Improved frequency accuracy and measurement speed

With a highly accurate and stable reference in your system, you can find signals more quickly by tuning to very narrow spans. For example, when frequency accuracy is improved, you can measure low level spurious signals much more quickly using narrow resolution bandwidths.

Connection to a house standard

The precision frequency reference module also allows you to lock a modular spectrum analyzer to an external reference, such as the HP 5051B cesium standard or the HP 5065A rubidium standard. In fact, you can use any external reference of 1, 2, 5, or 10 MHz.

Option 002—delete the ovenized oscillator

Option 002 deletes the ovenized oscillator and the accessory power pack from the HP 70310A, but retains the external reference input.

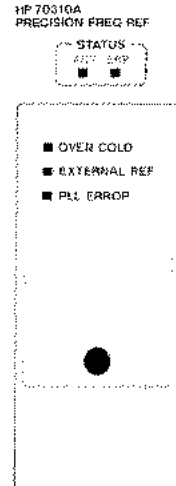
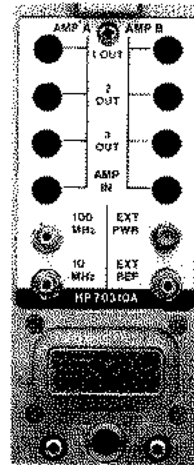

capability. This is a good low cost solution if you plan to connect a house standard or other external reference permanently to your HP 70000 modular spectrum analyzer.

Reference accuracy for other systems or modules

Option 001 adds two precision distribution amplifiers. Each amplifier offers three outputs leveled to 0 dBm. Each input will accept a -4 to -14 dBm signal from 5 to 300 MHz.

Using the output signals of the precision frequency reference or the 300 MHz signal from the HP 70900 local oscillator, you can lock together multiple analyzer systems without any degradation in system performance. The distribution amplifiers are a must if more than one LO is to be used with one reference module. The 300 MHz system reference can be routed to multiple front ends or to other modules.

In addition to the HP 70000 series reference signals, you can input house standards or other signals for distribution. The high isolation between the system's two sets of amplifiers allows distribution of external signals while distributing any internal reference signal.

User reference-locked output

Special options are available that provide a reference-locked frequency source for phase locking various system components. Outputs are available from 3 MHz to 25 MHz in 100 kHz steps and from 25 MHz to 50 MHz in 200 kHz steps. When a reference locked frequency source is used in conjunction with the distribution amplifiers, you can configure versatile systems that offer the following:

- An 18.4 MHz signal to the HP 70902A IF section for spectrum analyzer based multichannel systems.
- A 21.4 MHz output signal for a tracking generator when you need phase coherency; for example, if you are using the tracking generator as a source or if you are testing narrow-band devices in which frequency accuracy is critical.
- A 3.2 MHz signal to mix with the 3 MHz output of an IF section, which gives a 200 kHz signal suitable for digitizing.
- A fixed frequency reference anywhere in the range stated above.

System Building Blocks

Precision Frequency Reference

HP 70310A

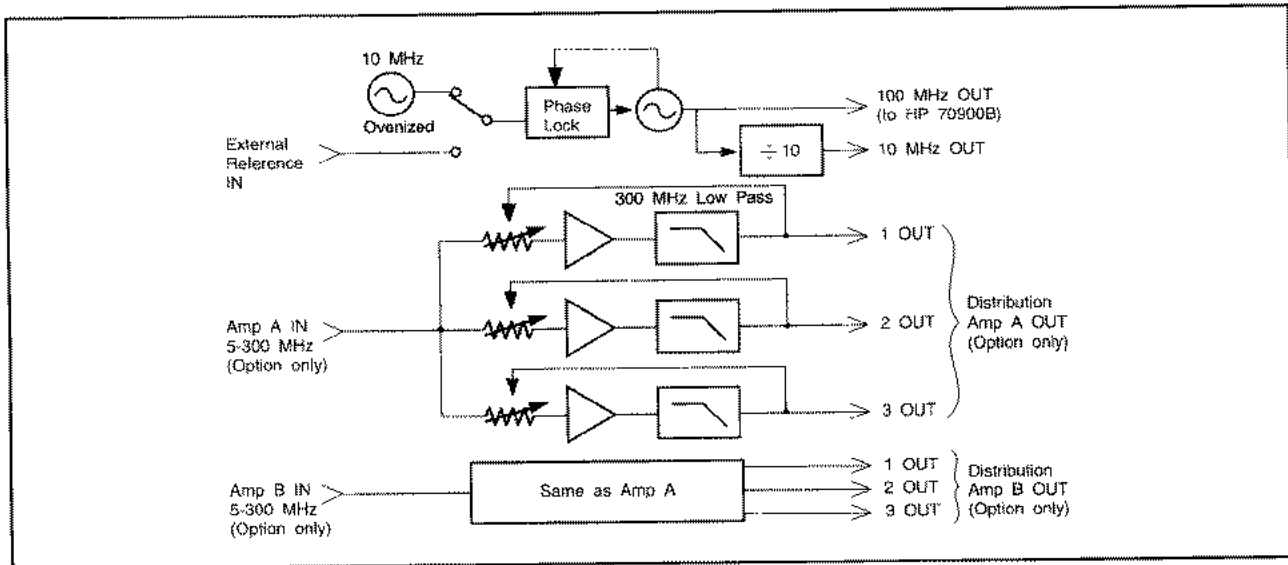

General Characteristics

Frequency reference accuracy aging	< 5×10^{-10} /day (7-day average); < 1×10^{-7} /year
Temperature stability	< 7×10^{-10} over 0° to 55° C
Warm-up time	< 96 hours to meet aging rate specification after < 24-hour off period < 30 days to meet aging rate specification after indefinite off period < 30 minutes to be within 1×10^{-8} of 24-hour warm-up frequency (at 25° C)

100 MHz output power 0 dBm (characteristic)

10 MHz output

Power	0 dBm (characteristic)
Harmonics	< -20 dBc
Spurious	< -80 dBc

External reference input

Input frequencies	1, 2, 5, or 10 MHz (use of 1, 2, or 5 MHz input signals may degrade system phase noise)
Input power range	-5 to +21 dBm
Impedance	50 Ω (characteristic)

Input signal characteristics required to meet HP 71100C/P, 71200C/P, and 71210C/P system specifications (10 MHz input)

Offset	Phase noise	Spurious
<input type="checkbox"/> 10 Hz	< -95 dBc/Hz	< -135 dBc
<input type="checkbox"/> 100 Hz	< -125 dBc/Hz	< -135 dBc
<input type="checkbox"/> 1 kHz	< -145 dBc/Hz	< -125 dBc

Option 001 distribution amplifiers

Input	
Frequency	5 MHz to 300 MHz
Power range	-4 to +4 dBm
Impedance	50 Ω (characteristic)
Output	
Power	3 outputs per amplifier leveled to 0 dBm (characteristic)

HP 70000 spectrum analyzer frequency accuracy

	With HP 70310A	Without HP 70310A
At 1 GHz span no aging (0° to 55° C)	± 17 Hz	± 10 kHz
At 1 GHz span after 1 yr aging (0° to 55° C)	± 117 Hz	± 13 kHz

The accessory power pack included with the HP 70310A supplies dc power to module the to maintain oven temperature when the mainframe is turned off. The power pack mounts to the rear of the mainframe and may be operated using ac power with the following characteristics: 47 to 444 Hz and 100, 120, or 240 V ac.

Weight 3.0 kg (6.6 lb) characteristic

Dimensions 1-slot module

Ordering Information

The HP 70310A is standard in the spectrum analyzers and lightwave signal analyzers. It also can be ordered separately for any modular measurement system.

When ordered separately, the HP 70310A is shipped with a set of cables that allow it to be connected to virtually any system. Cables shipped include a 3/8 span SMB, a 7/8 span SMB, and a 1.2 meter BNC to SMB cable.

HP 70310A precision frequency reference

- Option 001** distribution amplifier
- Option 002** delete ovenized oscillator
- Option 1BN** certificate of calibration
- Option 1BP** certificate of calibration and data
- Option 910** extra installation and verification manual (part number 70310-90059)
- Option 915** service manual set

System Building Blocks

MATE Module

HP 70590A H69, H72

MATE compatible modules

The HP 70590A Options H69 and H72 are test module adapters (TMAs) that make the HP 70000 spectrum analyzers compatible with the U.S. Air Force Modular Automatic Test Equipment (MATE) requirements. These 1-slot modules translate the Control Intermediate Interface Language (CIIL) into the HP 70000 series spectrum analyzer native code.

Module compatibility

These modules are compatible with the HP 71100C/P and 71210C/P spectrum analyzers. The analyzers include the following modules: HP 70900A/B local oscillator (firmware date 861015 or later); HP 70902A and 70903A IF sections; HP 70904A, 70905A/B, 70906A/B, and 70908A RF sections; HP 70907A/B external mixer interface modules; HP 70310A precision frequency reference module; HP 70001A mainframe; and HP 70205A and 70004A displays.

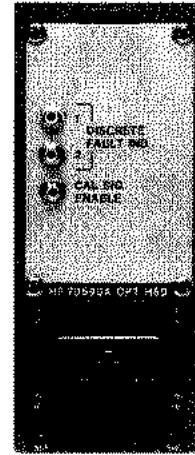
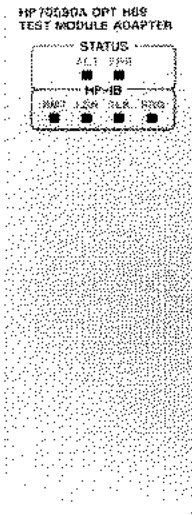

General Characteristics

HP 70590A/H69 TMA

A discrete fault indicator, DFI, allows you to determine if power to the spectrum analyzer is lost. A TTL calibration switch signal on the rear panel indicates that you need to apply the calibration signal. This calibration switch signal will operate upon issuance of the following CIIL commands: CNF for a confidence test and IST for Instrument Self Test.

DFI 1 and DFI 2	SMB (m), 50 Ω (nominal, rear panel)
CAL	SMB (m), TTL signal (rear panel)

HP 70590A/H72 TMA

A discrete fault indicator, DFI, allows you to determine if power to the spectrum analyzer is lost. Option H72 replaces the rear-panel cal indicator with front-panel connections and an internal switch. Either the 300 MHz, -10 dBm calibrator or your RF INPUT signal can be switched to the spectrum analyzer's RF Input. Upon issuance of the CNF or IST commands, the calibrator will be connected. Option H72 will degrade the spectrum analyzer's amplitude specifications by the cable and switch loss and flatness.

DFI 1 and DFI 2	SMB (m), 50 Ω (nominal, rear panel)
CAL IN	BNC (f), 50 Ω (nominal, front panel)
RF IN	Type-N (f), 50 Ω (nominal, front panel)
RF OUT	Type-N (f), 50 Ω (nominal, front panel)

Call your local HP sales representative for current ordering information.

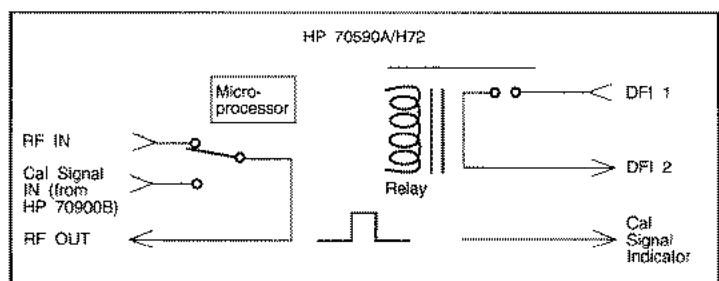
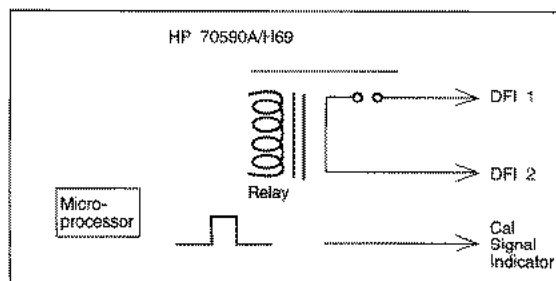

System Building Blocks

Microwave Transition Analyzer

HP 70820A

Measurement engine of the HP 71500A microwave transition analyzer system (see instrument section)

HP 70820A MICROWAVE TRANSITION ANALYZER
RANGE DC-40GHz

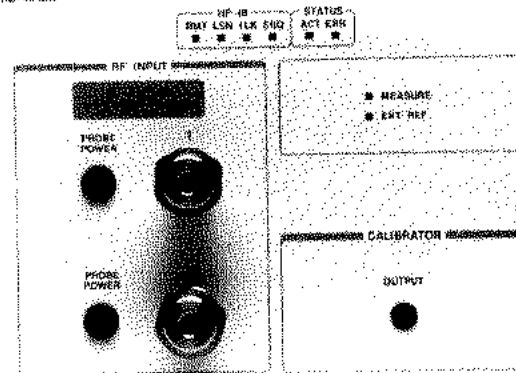

Architecture

The figure below shows a simplified block diagram of the microwave transition analyzer. The analyzer has two identical signal processing channels. Each channel samples and digitizes signals over an input bandwidth of dc to 40 GHz. The channels are sampled simultaneously (within 10 ps), permitting accurate ratioed amplitude and phase measurements. A single synthesized low-noise oscillator drives a step recovery diode, the output of which

is split into two pulse trains that drive the microwave samplers. The microwave samplers and the analog-to-digital converters (ADCs) are run at the same frequency. The maximum sampling frequency is 20 MSa/s (20 million samples per second).

The signal at the output of the samplers is processed by a 10-MHz-bandwidth low-pass intermediate frequency (IF) strip. The IF circuitry includes a programmable shaping amplifier to compensate for the

sampler's IF response roll-off, 60 dB of step gain to optimize the signal level into the ADC, and variable low-pass filtering to remove noise and sampler feedthrough. The trigger circuitry is at the end of the analog path. Triggering on IF signals (instead of RF input signals) allows the microwave transition analyzer to be internally triggered to 40 GHz. Enhancements to the hardware trigger are available through the use of digital signal processing.

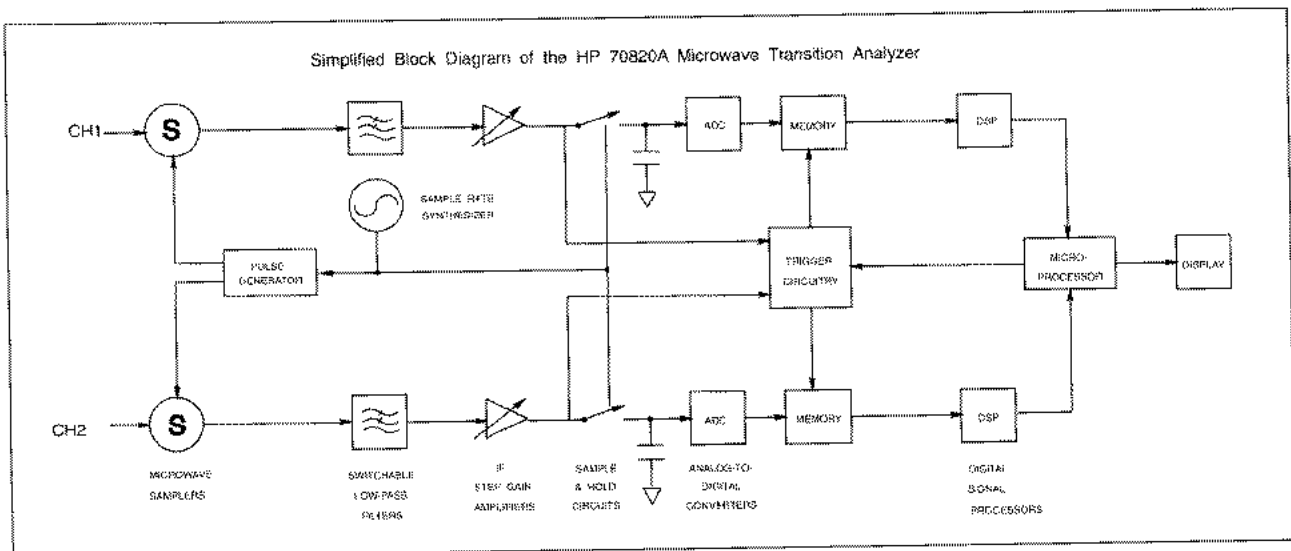

System Building Blocks

Microwave Transition Analyzer

HP 70820A

Specifications

Input/output

Input channels

Operating input range	<10 dBm (± 320 mV, dc +ac peak, includes the dc offset)
Maximum safe input	16 dBm peak (± 2 V pk-pk)

CAUTION: INPUTS ARE DC COUPLED

Number of input channels	2
Input connectors	2.4 mm (male)
Input crosstalk	< -70 dB
Nominal input impedance	50 Ω
Programmable dc Offset	± 320 mV

Pulse generator (modulator out)

Repetition frequency	52.9 Hz-5 MHz
Repetition period	6.553 ms-200 ns
Pulse width	6.552 ms-100 ns
Level	TTL into 50 Ω
Transition time	< 5 ns
Connector	Rear panel, SMB (male)

The pulse generator is phase locked to the 10 MHz reference. Pulse width and repetition period are variable in 100 ns steps. Inaccuracies in the pulse widths are dominated by the transition times (< 5 ns).

IF calibrator output

Connector	Front panel, SMA (female)
-----------	---------------------------

Reference output

Connector	Rear panel, SMB (male)
Frequency	10 MHz
Amplitude	0.45 V p-p square wave (-2 dBm fundamental) into 50 Ω ; 0.55 V p-p (0 dBm), typical

External reference input

Connector	Rear panel, SMB (male)
Frequency	10 MHz
Amplitude	0 \pm 5 dBm (0.13 V_{rms} to 0.4 V_{rms}) sine-wave or square wave (ECL) into 50 Ω

DAC output (accessible only through HP-IB programming)

Voltage range	0-10 V
D/A resolution	12 bits
Connector	Rear panel, SMB (male)
Drive capability	5 mA

Probe power supplies

Supply	Tolerance	Current drive
<input type="checkbox"/> +15 V	± 0.5 V source	130 mA
<input type="checkbox"/> -12.5 V	± 0.5 sink	45 mA

Sync input

Connector	Rear panel SMB (male)
Input level required	TTL (into high impedance)
Sync modes	Force sweep; arm internal trigger
Nominal delay from sync input to channel input to A/D	280 ns, 10 MHz IF
	450 ns, 7 MHz IF
	11 μ s, 100 kHz IF

Forced sweep mode

Forced sweep occurs on transition from low to high of sync input. Must remain high for 250 ns.

<input type="checkbox"/> Forced sweep uncertainty	± 100 ns
<input type="checkbox"/> Minimum pulse width	250 ns
<input type="checkbox"/> Maximum pulse width	Determined by sweep time. Next sweep will not occur until the next low-to-high transition.

Arm internal trigger mode

Arm sweep on high level of sync input

Minimum delay from sync input going high to internal trigger event	100 ns
--	--------

Power requirements 90 W, supplied by mainframe

Weight Approximately 9 kg (20 lb)

Size Four-slot module

Ordering Information

HP 70820A microwave transition analyzer

Option 003 add tutorial kit

Option 910 add extra set of user manuals

Option 915 add service manuals

Option W30 three year extended repair service

Option W50 five year extended repair service

System Building Blocks

Local Oscillator

HP 70900B

Compatibility

The HP 70900B is the master control module for the modular spectrum analyzers. It is also a component of the lightwave signal analyzers. It can control the following slave modules: HP 70902A and 70903A IF sections; HP 70904A, 70905A/B, 70906A/B, 70908A sections; HP 70907A and 70907B external mixer interface module; HP 70300A and 70301A tracking generators; HP 70620A, 70620B and 70621A preamplifiers; HP 70700A high speed digitizer; and HP 70310A precision frequency reference and HP 70810B lightwave section.

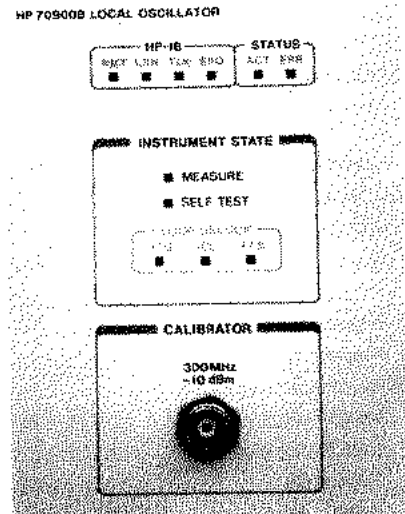
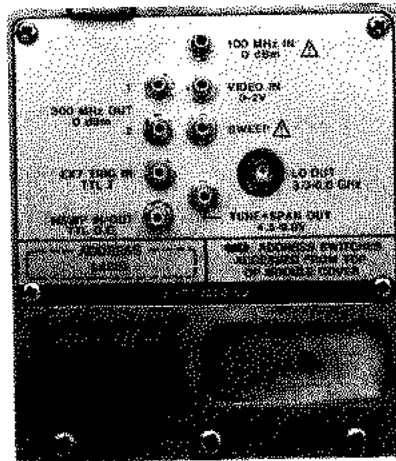

Dual functionality as an analyzer

The HP 70900B LO has two main functions in the HP 70000 spectrum analyzers: as the synthesized local oscillator (LO) and as the master control module for the system.

As a spectrum analyzer local oscillator, it affects phase noise, stability, and frequency accuracy. The HP 70900B is the reason that the analyzer has excellent phase noise performance of -108 dBc/Hz at 10 kHz offset from the carrier.

The synthesis technique has millihertz resolution for accurate frequency control. The fast tuning speed of the LO directly relates to the tuning speed of the analyzer.

As the master control module, the HP 70900B determines system features, slave module control, command processing speed, and HP-IB speed. The combination of hardware and processing power provides fast tuning for surveillance applications and automatic testing.

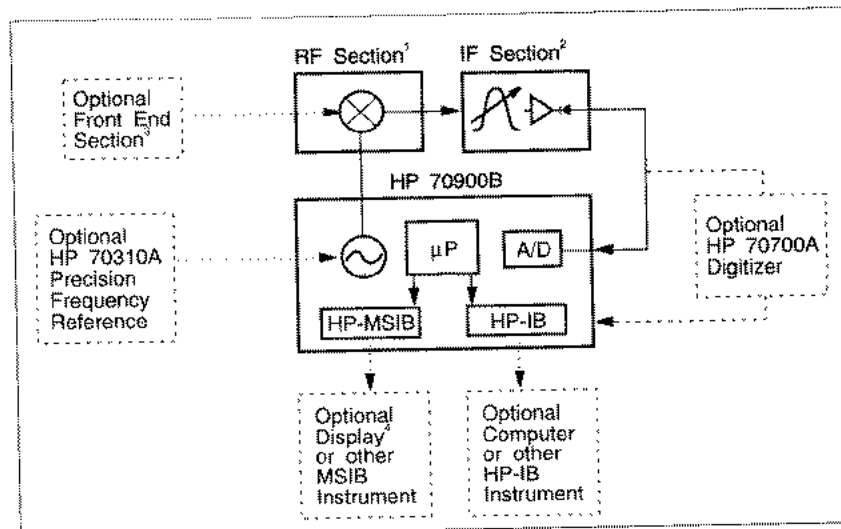

System requirements

When configured as a spectrum analyzer, the HP 70900B requires an IF Section and either an RF section or an HP 70907A/B external mixer interface module. Only one RF section is allowed. The LO does not require a display to operate over the HP-IB.

Diagram notes

- 1 Includes HP 70904A/70905A/B/70906A/B/70907B/70908A.
- 2 Includes HP 70902A/70903A.
- 3 Includes HP 70620B/70621A/70810A/70907B.
- 4 Includes HP 70004A/70205A/70207B.

System Building Blocks

Local Oscillator

HP 70900B

Source and offset tracking capability

Combine the HP 70900B with the HP 70300A or 70301A tracking generators to get a source from 20 Hz to 18 GHz. Or combine the HP 70300A/70900B with an HP 70000 spectrum analyzer for offset tracking applications (see Tracking Generator section).

Distributed processing with downloadable programs

Measurement routines to operate the analyzer, make decisions, and branch to other routines can be downloaded into the analyzer. Once downloaded, you activate the routines manually from the front panel, or execute them from a computer as a high level command. Let the computer do other things while the analyzer takes data, performs high level math operations—such as a probability distribution function—and then returns information to the computer.

A debug mode is a useful aid in the development of downloadable programs and standard programs written on a computer.

Limit lines

Enter limit lines directly from the front panel. The limit lines give pass/fail indications (either an on-screen warning or a beep) if the trace data falls outside the limit. This is useful for component tests or digital radio masks.

Extensive markers

Extensive marker capability allows you to simplify complex tasks. Marker noise and delta marker allow you to quickly measure carrier to noise ratio. Various marker read-outs, such as period and $1/T$, are advantageous to those working in radar with pulsed RF signals.

Delta markers can be placed on different traces to compare results from previously stored data. Up to five on-screen markers are available. The peak, minimum, left, right, and closest peak allow you to move about the trace easily and quickly.

Trace math and more

Numerous trace math functions are available manually, and even more are available via programs. Manually you can add and subtract traces and manipulate the trace versus a display line for proper on-screen position. You also have manual control to title your display and to use a display line and threshold lines. Trace lengths can be varied from 3 to 2048 points. Over HP-IB or with downloadable programs, you can use logarithms, exponents, and more complex routines such as FFTs and probability distribution functions.

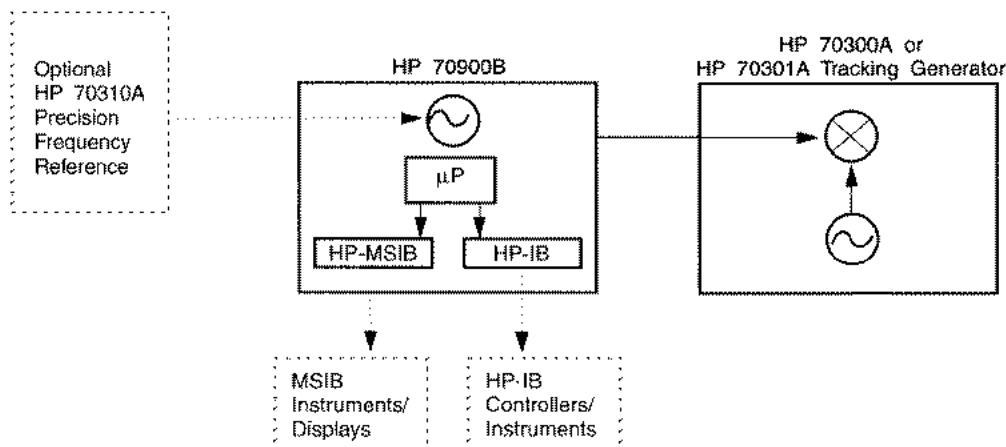

HP 70900B requirements and optional capability when used as an analyzer

System Building Blocks

Local Oscillator

HP 70900B

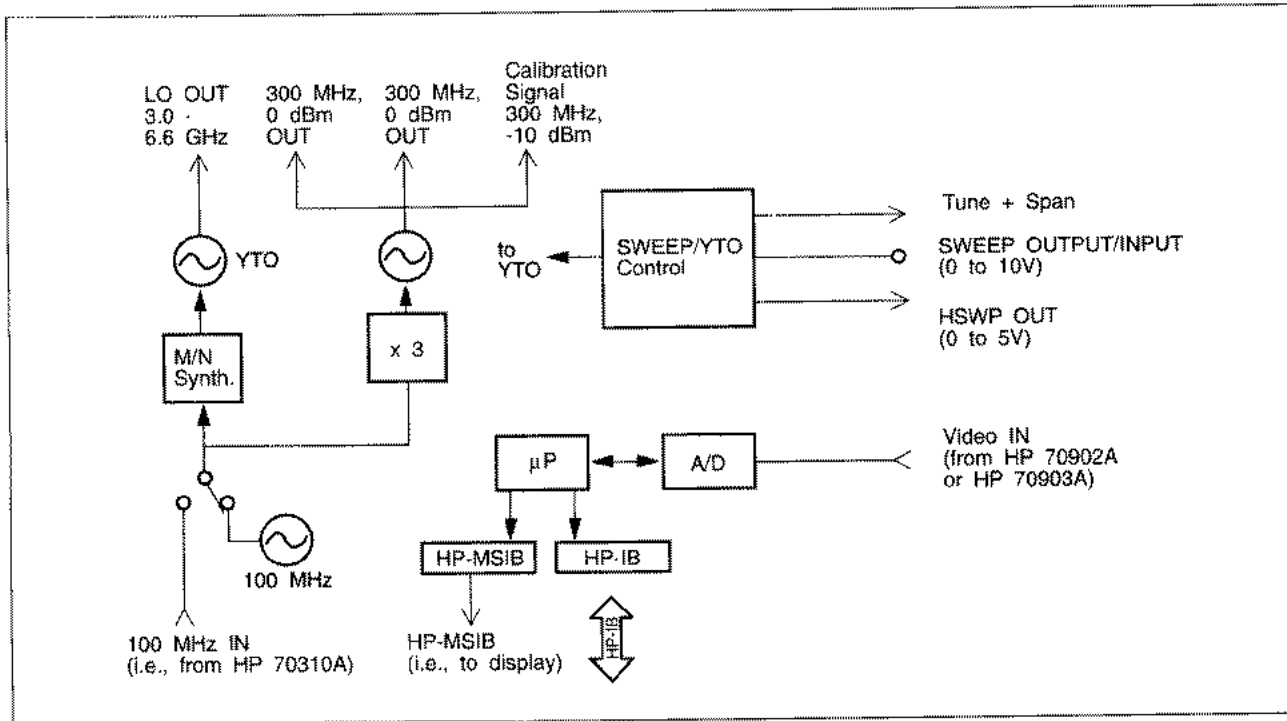

HP 70900B local oscillator/control module block diagram

Secure environments

Follow one of several procedures to ensure that equipment is secure enough when it leaves your environment. The PARTIAL ERASE command erases all unprotected internal memory (user-defined variables, traces, functions, keys, and files) and reserved memory (instrument settings and predefined variables) except for cal factors and serial number. The ERASE command provides maximum security, as all internal memory (protected or not), reserved memory, cal factors, serial number, and input buffer are completely erased from memory.

Custom applications

Other spectrum analyzer-based solutions are possible using the HP 70900B. These include using the HP 70900B with an LO distribution amplifier to make phase coherent multi-channel receivers. Refer to the Configuration Examples section for more information.

General Characteristics

300 MHz calibrator output	BNC (f), 50 Ω (nominal)
Output power	-10 dBm \pm 0.3 dB
Frequency accuracy	300 MHz x frequency reference accuracy
Ext freq ref input	SMB (m), rear panel, 50 Ω (nominal), 100 MHz
Power required	0 dBm \pm 3 dB maximum
Max. phase noise	-150 dBc/Hz at \geq 10 kHz offset
Maximum spurious	< phase noise or -115 dBc, whichever is greater
Sweep output/input	SMB (m), rear panel, 0-10 V for sweep \geq 50 ms
Accuracy	2%
Tune + span output	SMB (m), rear panel, 4.5-8.9 V (1.5 V/GHz)
HSWP output/input	SMB (m), rear panel, TTL open collector
Sweep condition	low = not ready to sweep
Maximum delay	200 μ s from HSWP high to sweep
Max. current draw	16 mA
HP-IB codes	SH1 AH1 T6 L4 SR1 RL1 DC1 PP0 DT1 E2 C1

Ordering Information

HP 70900B local oscillator and control module

- Option 1BN** certificate of calibration
- Option 1BP** certificate of calibration and data
- Option 512** 1 MB memory
- Option 910** extra user's manual
- Option 915** service manual set
- Option W30** two additional years of return-to-HP warranty (3 years total)

System Building Blocks

IF Sections

HP 70902A/70903A

HP 70902A
10 Hz to 300 kHz
resolution bandwidths

HP 70903A
100 kHz to 3 MHz
resolution bandwidth

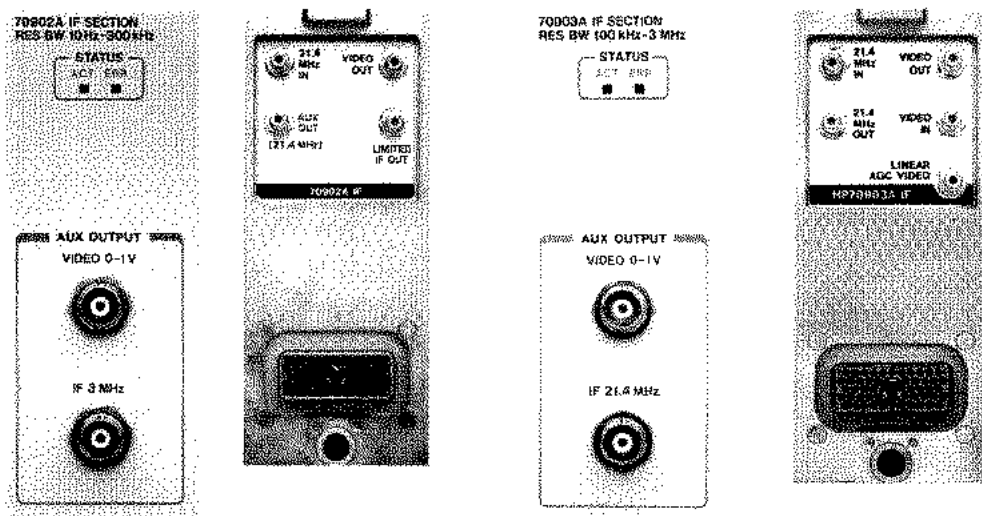

IF sections for analyzers

The intermediate frequency (IF) sections provide signal processing elements required for the spectrum analyzers and lightwave signal analyzers. The HP 70902A provides narrow resolution bandwidths, from 10 Hz to 300 kHz, while the HP 70903A provides 100 kHz to 3 MHz resolution bandwidths. You can use either or both IF sections in any of the configured systems.

Bandwidths in 10% increments

Maximize measurement speed using 10% incremental bandwidths. Wider bandwidths offer the most speed, whereas narrow bandwidths offer more resolution and sensitivity. The 10% incremental bandwidth steps offer you the best choice of bandwidth sizes. The bandwidths can also be changed in a 1, 3, 10 sequence.

Logging amplifier and detector

Calibrated logging amplifiers provide superb amplitude accuracy for the analyzers. Four detection modes are available to properly display a variety of signals:

- positive peak detector for impulsive signals
- normal—alternate positive and negative peak for CW signals and many others
- sample for observing modulation in fixed tuned (zero span) mode and noise averaging
- negative peak detector

Outputs

The 3 MHz IF output on the HP 70902A and the 21.4 MHz output on the HP 70903A allow connection to other instruments such as demodulators, digitizers, and oscilloscopes. The HP 70903A has a linear AGC video output that provides a constant peak amplitude output of the detected modulation component of the input signal. You can use this in zero-span (fixed-tuned) to drive an oscilloscope for pulsed RF signals, an audio amplifier for AM signals, or a sync processor. The limited IF output on the HP 70902A can be used with frequency counters.

System Building Blocks

IF Sections

HP 70902A/70903A

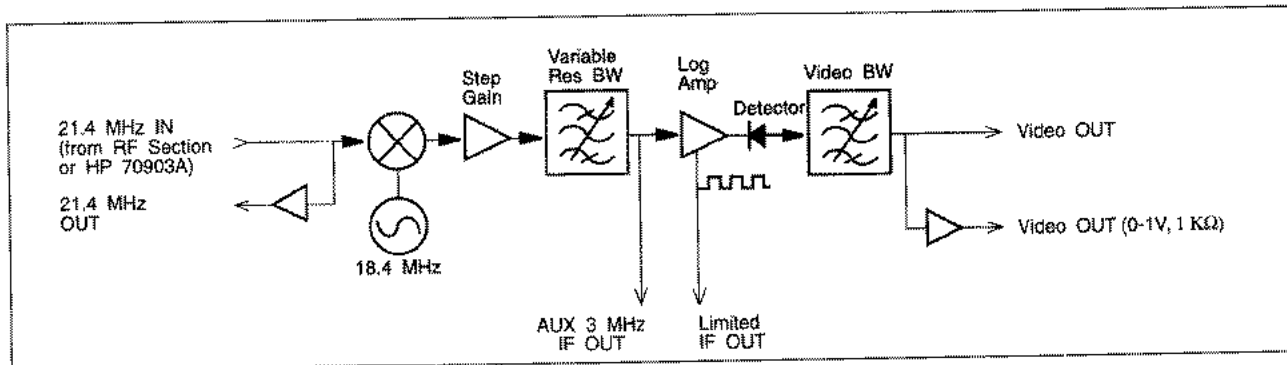

HP 70903A IF section block diagram

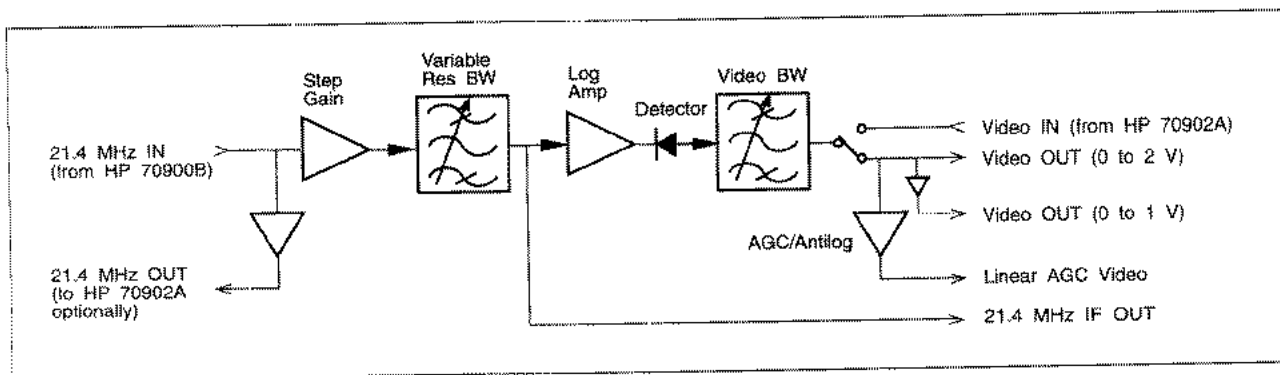

HP 70902A IF section block diagram

General Characteristics

HP 70902A inputs/outputs

Auxiliary video output	BNC (f), 0–1 V, 1 k Ω (nominal), front panel
3 MHz IF output (linear)	BNC (f), 50 Ω , 1.5:1 VSWR (nominal), front panel
Output power	-15 dBm nominal with -10 dBm RF input, 0 dB attn and -10 dBm reference level
Limited IF output	SMB (m), 1 \pm 0.5 V p-p (nominal), rear panel

HP 70903A inputs/outputs

Auxiliary video output	BNC (f), 0 to 1 V, 100 Ω (nominal), front panel
21.4 MHz IF output (linear)	BNC (f), 50 Ω , 1.5:1 VSWR (nominal), front panel
Output power	-15 dBm nominal with -10 dBm RF input, 0 dB attn and -10 dBm reference level

Linear ADC video output

Leveled output	1 V, 50 Ω , SMB (m) (nominal)
Distortion (-30 dBm input, 90% AM, $F_{mod} = 10$ kHz)	< 8% THD
AGC attack time (periodic signals)	30 ms
AGC decay time (periodic signals)	300 ms

Ordering Information

HP 70902A IF section

- Option 910 extra user's manual set
- Option 915 service manual set

HP 70903A IF section

- Option 1BN certificate of calibration
- Option 910 extra user's manual
- Option 915 service manual set

System Building Blocks

IF Sections

HP 70911A

Ultra-wide bandwidth IF module

100 Hz to 26.5 GHz

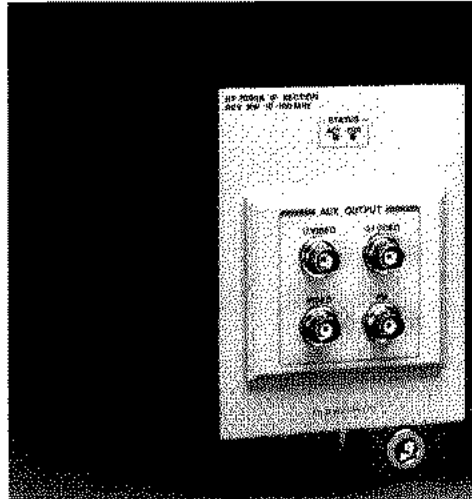

The HP 70911A ultra-wide bandwidth IF module adds receiver functionality to certain HP 70000 series spectrum analyzers. Designed specifically to work with the HP 71209A/P Option 001 analyzer, it adds receiver bandwidths of 10 MHz to 100 MHz in 10% increments. Adding the HP 70911A to the HP 71209A/P Option 001 constitutes the HP 71910A wide-bandwidth surveillance receiver.

The HP 71910A/P receiver monitors signals from 100 Hz to 26.5 GHz. It provides a cost-effective combination of search and wide-bandwidth collection capabilities for surveillance and signal monitoring applications. Its flexibility makes it an ideal downconverter in stimulus-response applications.

To search for signals, the receiver sweeps over user-specified spans up to 26.5 GHz wide using bandwidths up to 3 MHz. A wide dynamic range ensures that signals of various amplitudes are quickly identified. Once a signal is located, the receiver is fixed-tuned and the wide IF bandwidths are used for signal collection. (Bandwidths up to 36 MHz are available with microwave preselection, and up to 100 MHz unpreselected.) A linear IF signal path provides good signal fidelity with standard outputs of 321.4 MHz IF and linear video. Optional outputs include 70 and 140 MHz IF, analog I/Q, and demodulated FM.

For more about the HP 71910A wide bandwidth surveillance receiver, see page 37.

Ordering Information

HP 70911A ultra-wide bandwidth IF module

Important: Options 001 through 007 are circuit boards. There are only four circuit board slots available. Option 004 consists of two circuit boards. When ordering, be certain that the total number of circuit boards does not exceed four.

Option 001 70 MHz IF output (one board)

Option 002 140 MHz IF output (one board)

Option 004 analog I/Q output (two boards)

Option 005 FM output (one board)

Option 007 70 MHz IF channel filters (one board); requires Option 001

Option 098 LO firmware upgrade, CPU board upgrade, and 1 MB RAM

Option 099 LO firmware upgrade and 1 MB RAM

System Building Blocks

RF Sections

HP 70904A

Part of the spectrum analyzers and lightwave signal analyzers

100 Hz to 2.9 GHz RF section

Attenuator and mixer conversion stage

RF section for analyzers

The HP 70904A RF section provides the 100 Hz to 2.9 GHz broadband input conversion for the HP 71100C/P spectrum analyzer and the HP 71401C lightwave signal analyzer.

RF performance

The HP 70904A RF section contains an input attenuator and a mixer. The RF mixer converts the incoming RF signals to the intermediate frequency (IF) for further processing. The broadband, low noise mixer offers the performance needed to make high dynamic range measurements.

The input attenuator can be automatically coupled either to the reference level for mixer protection or to the highest mixer level to maximize dynamic range. The input attenuator varies from 0 to 70 dB in 10 dB steps. Option H25 has 5 dB step attenuators.

DC blocking capacitor

You can switch in a dc blocking capacitor to prevent damaging dc signals from entering the input attenuator and mixer. This section offers both ac and dc coupled inputs.

Probe power

If you need to probe your circuit, you can drive the probe using the connection available on the front panel. High impedance probes, such as the HP 41800A and 85024A, are available.

Outputs

A buffered LO output is available to drive tracking generators or other modules such as the external mixer interface module.

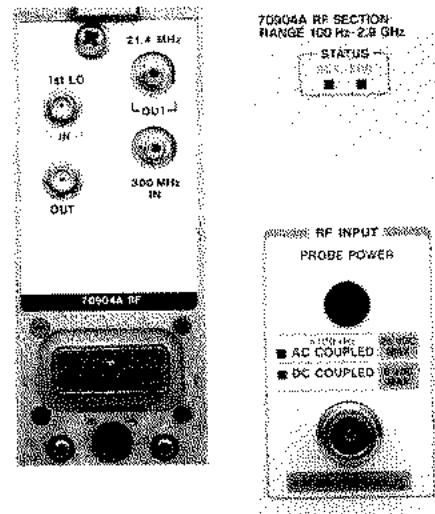

General Characteristics

Inputs/outputs

RF input (100 Hz to 2.9 GHz)	Type-N, 50 Ω (nominal), front panel
LO emissions	< -100 dBm (10 dB attn)
<input type="checkbox"/> VSWR (≥ 10 dB attn)	< 1.3:1 (nominal)
<input type="checkbox"/> VSWR (0 dB attn)	< 2.9:1 (nominal)
Probe power output	15 V, -12 V and ground, 150 mA max., front panel
First LO auxiliary output	SMA (m), rear panel, 50 Ω (nominal)
Frequency range	3.0–6.6 GHz
Power range	+1.5 dBm–12 dBm

Ordering Information

HP 70904A RF section

- Option 1BH** general export license
- Option 1BN** certificate of calibration
- Option 1BP** certificate of calibration and data
- Option 910** extra user's manual
- Option 915** service manual set

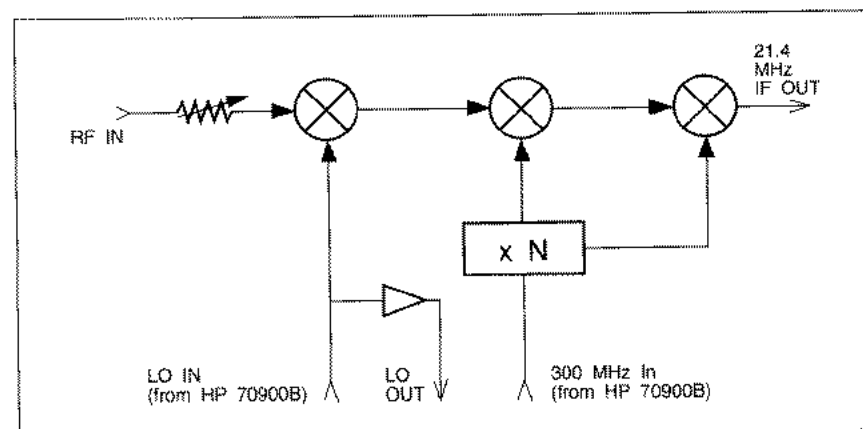

System Building Blocks

RF Sections

HP 70905A

Part of spectrum analyzers

50 kHz to 22 GHz RF section

Attenuator and mixer conversion stage

RF section for analyzers

The HP 70905A RF section provides the broadband inputs for the spectrum analyzers. The RF section converts the input signals to an intermediate frequency for further processing.

RF performance

This broadband, low noise mixer offers the performance needed to make high dynamic range measurements. The HP 70905A operates to 22 GHz.

Compatibility

The HP 70905A has a 0 to 70 dB input attenuator, variable in 10 dB steps. In manufacturing environments where signals are known, you can save money by using this module without a preselector.

Signal identification

For unpreselected microwave spectrum analyzers, an automatic signal identification routine returns the frequency of an unknown signal. Simply place a marker on a signal response. If you have several unknown frequencies simultaneously present at the analyzer input, a preselected spectrum analyzer, like the HP 71209A/P, is recommended.

Outputs

The 321.4 MHz output and input are available when the module is tuned above 2.7 GHz. This provides an unpreselected signal which can be demodulated or detected. The first LO auxiliary output allows operation with tracking generators and external mixer interface modules

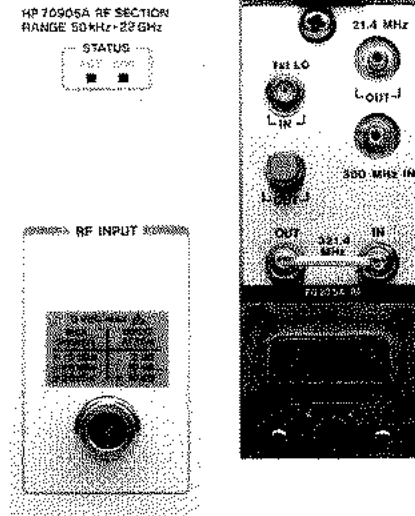

General Characteristics

Inputs/outputs

RF input	Type-N (f), 50 Ω (nominal), front panel
LO emissions	< -10 dBm with 10 dB attn, VSWR (\geq 10 dB attn)
	<i>Freq (GHz)</i> <i>VSWR (nominal)</i>
	0-12.7 < 1.7:1
	12.5-18.0 < 2.0:1
	18.0-22 < 2.5:1

321.4 MHz IF output	SMB (m), rear panel, 50 Ω (nominal)
Frequency range	100-700 MHz
Amplitude level	Tracks 21.4 MHz IF with -21 dBm \pm 3 dB offset in 321.4 MHz bands only)
First LO auxiliary output	SMA (f), rear panel, 50 Ω (nominal)
Frequency range	3.0-6.0 GHz
Power range	+1.5 dBm-12 dBm

Ordering Information

HP 70905A RF section

- Option 1BN certificate of calibration
- Option 1BP certificate of calibration and data
- Option 910 extra user's manual
- Option 915 service manual set

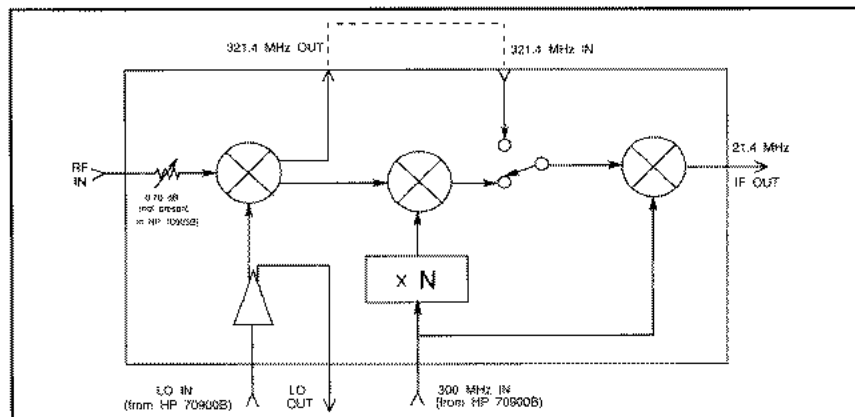

System Building Blocks

RF Sections

HP 70908A

RF section for analyzers

The HP 70908A RF section provides fundamentally mixed 100 Hz to 22 GHz broadband input conversion for the HP 71210C spectrum analyzer and the HP 71400C lightwave signal analyzer.

Fundamental mixing

Fundamental mixing provides a means of achieving unprecedented sensitivity for microwave measurements and for high speed lightwave modulation rates. This sensitivity allows you to reduce microwave spurious test times from days to hours.

Improved sensitivity also improves second and third order dynamic range. Excellent dynamic range is obtained with an analyzer that has both good sensitivity and good distortion performance (TOI and SOI). These principles apply to all analyzers and testers that contain this module.

Dynamically tracking preselector

The internal preselector dynamically tracks the analyzer's tuning. The preselector is therefore continuously peaked, which saves you time and provides excellent amplitude accuracy.

RF performance

The HP 70908A also contains a 70 dB step attenuator variable in 10 dB steps. Option H25 provides a 5 dB step attenuator.

Outputs

The 321.4 MHz IF output allows you to access the converted RF signal. You can then detect and display this signal on external equipment.

The first LO auxiliary output allows operation with tracking generators and external mixer interface modules.

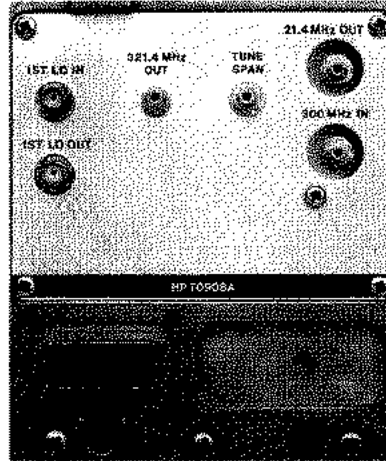

HP 70908A RF SECTION
RANGE 100 Hz - 22 GHz

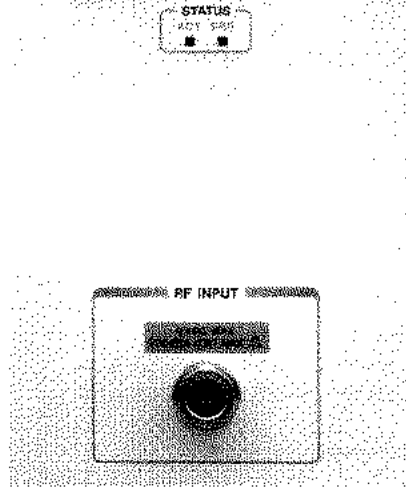

General Characteristics

Inputs/outputs

RF input	Type-N (f), front panel, 50 Ω (nominal)	
LO emissions	< -100 dBm low band (0 to 2.9 GHz) (10 dB attn) < -50 dBm high band (2.7 to 22 GHz)	
VSWR (≥ 10 dB attn)	<i>Freq (GHz)</i>	<i>VSWR (nominal)</i>
	0-12.8	<1.9:1
	12.8-18.0	<2.3:1
	18.0-22.0	<2.5:1
321.4 MHz IF out	SMB (m), rear panel, 50 Ω (nominal, switched), available for all input freq	
Bandwidth	>15 MHz	
Amplitude level	-15 dBm for -10 dBm input to mixer (nominal)	
First LO auxiliary out	SMA (f), rear panel, 50 Ω (nominal); VSWR (≥ 10 dB attn) < 3:1	
Frequency range	3.0 to 6.6 GHz	
Power range	+5 to 10 dBm	

Ordering Information

HP 70908A RF section

- Option 098 controller board upgrade kit (see HP 70860A)
- Option 099 RAM/ROM upgrade kit (see HP 70861A)
- Option 1BH general export license
- Option 1BN certificate of calibration
- Option 1BP certificate of calibration and data
- Option 910 extra user manual
- Option 915 service manual set

System Building Blocks

RF Sections

HP 70909A/70910A Including Z40

100 Hz to 26.5 GHz RF sections

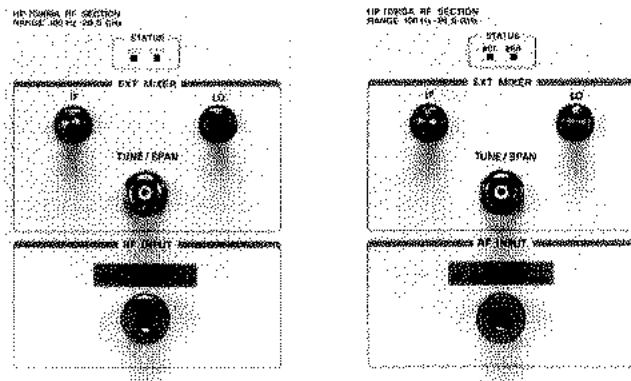

RF sections for analyzers

The HP 70909A and 70910A RF sections provide coverage from 100 Hz to 26.5 GHz. They are used in the HP 71209A/P spectrum analyzer.

Improved sensitivity

Diode-pair mixing provides lower conversion loss, allowing the spectrum analyzer to have sensitivities that compete with fundamentally mixed designs. The sensitivity is also improved by the use of a built-in preamplifier before the first mixer (in the microwave path).

HP 70910A features

The HP 70910A adds a switchable bypass path around the YIG tuned

filter (YTF) for making very sensitive measurements when extraneous signals are not a problem. Also, the HP 70910A ensures that the minimum bandwidth through the YTF is greater than 36 MHz and the minimum bandwidth through the low band path is greater than 45 MHz. The HP 70909A does not have the bypass switch, and the bandwidth through the YTF is commonly around 27 MHz.

External mixing

For millimeter measurements, these RF sections include the extra switching and signals necessary to connect external mixers, including HP 11974 series preselected mixers. The

HP 70909A Option Z40 makes use of this capability and integrates preselected mixing to 40 GHz. The switching scheme in the Option Z40 allows a continuous sweep from 100 Hz to 40 GHz.

Outputs

A switched LO is routed to the front panel for connection to an external mixer. Rear panel outputs include the 3 to 6.6 GHz LO, and IFs at both 321.4 and 21.4 MHz. The spectrum analyzer adjusts gain within the module to keep a constant relationship between the power out of the input attenuator and the IF outputs.

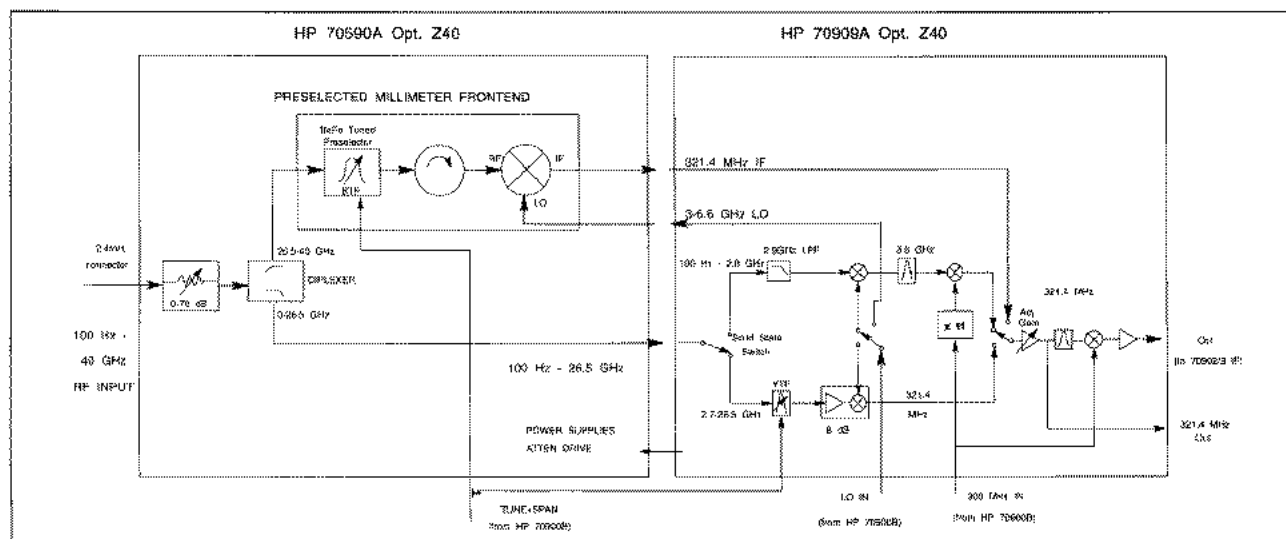

System Building Blocks

RF Sections

HP 70909A/70910A Including Z40

General Characteristics

HP 70909A and HP 70910A RF sections (100 Hz to 26.5 GHz)

RF Input	APC 3.5, 50 Ω (nominal)		
LO emissions (10 dB attn)	Total signal power		
	<i>Center frequency</i>	<i>Preselector on</i>	<i>Preselector off (HP 70910A)</i>
	0–2.9 GHz	<-100 dBm	<-80 dBm
	2.9–26.5 GHz	<-100 dBm	<-50 dBm
VSWR (≥ 10 dB attn)	<i>Freq (GHz)</i>	<i>VSWR (nominal)</i>	
	0–6.2	< 1.4:1	
	6.0–26.5	< 2.0:1	
321.4 MHz external IF input	SMA (f), 50 Ω (nominal)		
Return loss	≥ 14 dB from 271.4 to 371.4 MHz		
Maximum safe input level (spec)	ac, 0 dBm; dc, ± 3 V		
Noise figure	< 7.0 dB		
SHI	> (+ 30-CL) dBm		
TOI	> (+ 10-CL) dBm		
	(CL=external mixer conversion loss)		
Tune and span output	BNC (f), > 10 kΩ load impedance		
Voltage range	0 to -13.25 V		
Tuning sensitivity	RF input selected, 0.5 V/GHz RF freq		
	EM input selected, 1.5 V/GHz LO freq		
Preselector DAC	(8 bit DAC)		
Voltage range	RF input selected	N=1 +13.3 mV	
		N=2 +26.7 mV	
		N=4 +53.3 mV	
	Ext mixer input selected	+40.0 mV	
First LO output	SMB (f), 50 Ω, VSWR < 2.1:1		
Freq. range	3.0–6.6 GHz (spec)		
Output power (spec)	25° C ± 5° C		0°–55° C
	□ Minimum	14.5 dBm	14.0 dBm
□ Maximum	17.0 dBm	17.5 dBm	
321.4 MHz IF output	Rear panel SMB (m), 50 Ω (nominal)		
Bandwidth	-3 dB bandwidth		
	<i>RF frequency</i>	<i>HP 70909A</i>	<i>HP 70910A (spec)</i>
	0–2.9 GHz	> 48 MHz	> 48 MHz
	2.7–26.5 GHz (preselector ON)	> 27 MHz	> 36 MHz
	2.7–26.5 GHz (preselector OFF)	N/A	>200 MHz
	EM input	>200 MHz	>200 MHz
Level	-5 dBm; for 0 dBm RF input and 10 dB atten		
Return loss	14 dB, at 321.4 ± 50 MHz		

Ordering Information

HP 70909A RF section

Option Z40 configuration to work with HP 70590A Option Z40

Option 098 controller board upgrade kit (see HP 70860A)

Option 099 RAM/ROM upgrade kit (see HP 70861A)

Option 1BN certificate of calibration

Option 1BP certificate of calibration with data

Option 910 extra user manual

Option 915 service documentation and software

HP 70910A RF section

Option 098 controller board upgrade kit (see HP 70860A)

Option 099 RAM/ROM upgrade kit (see HP 70861A)

Option 1BN certificate of calibration

Option 1BP certificate of calibration with data

Option 910 extra user manual

System Building Blocks

External Mixer Interface Module

HP 70907B

Add external mixers to any HP MMS spectrum analyzer

Select multiple external mixers with softkeys

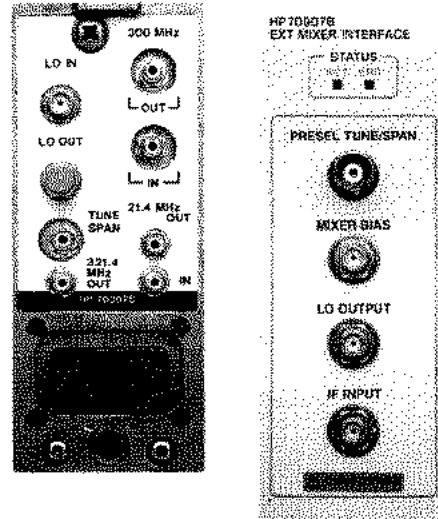

The HP 70907B external mixer interface module (EMIM) is the interface needed to use the HP 11974 series preselected millimeter mixers with HP 70000 modular spectrum analyzers.

The HP 70907B external mixer interface module is also compatible with the HP 11970 series millimeter mixers, which extend to 110 GHz, and with millimeter mixers from other manufacturers, which extend to 325 GHz. (Other mixer series are not preselected.)

System configuration

The HP 70907B provides the HP 11974 mixers with a swept LO signal and a tune and span signal. The HP 11974 mixers return an IF signal to the HP 70907B, where it is converted to 21.4 MHz and output to an IF module. See the figure below.

HP 70907A upgrade

An HP 70907A can be upgraded to the HP 70907B with the HP 70907A-K74 upgrade kit¹. The kit can be installed by the customer in about one hour. The HP 70000 series LO module (HP 70900A or B) must meet certain date code requirements. (See Ordering Information.)

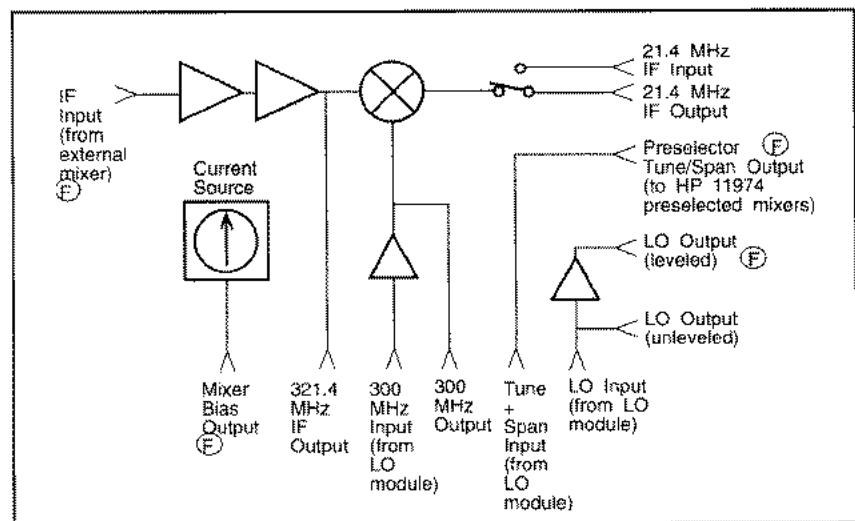

HP 70907B EMIM block diagram

System Building Blocks

External Mixer Interface Module

HP 70907B

Specifications

Internal 321.4 MHz calibrator accuracy ±0.6 dB at -35 dBm

Input/output characteristics²

Front panel only; see module characteristics for more detailed information.

Preselector tune/span

Voltage range (specification)	<4.5 to >9.9 V
Tuning sensitivity (specification)	1.5 V/GHz
Load impedance	>10 kΩ (nominal)

Mixer bias

Maximum voltage (characteristic)	3.3 V
Current range, -2 V < V out < 2 V	
Range (specification)	-10 to +10 GHz
Resolution (characteristic)	<20 μA
Accuracy (specification)	±30 μA
Source impedance	>1 MΩ (nominal)

LO output

Frequency range (specification)	3.0 to 6.6 GHz
Output power (specification)	6 dBm ±1.5 dB
VSWR (characteristic)	≤ 1.9:1
Impedance	50 Ω (nominal)

IF input

Frequency (characteristic)	321.4 MHz
Maximum safe input level (characteristic)	
<input type="checkbox"/> ac	≤ 30 dBm
<input type="checkbox"/> dc	±3 V
VSWR at 321.4 ±5 MHz (characteristic)	≤ 1.8:1
Impedance	50 Ω (nominal)

General specifications and characteristics

Temperature	0° to +55° C
Storage	-10° C to +75° C
Weight	2.8 kg (6.2 lb)
Dimensions	1 slot module

¹ Mixer bias is converted to preselector peak, resulting in activation of a preselector peaking with the BIAS PEAK function. Sweep times must be manually controlled in wide spans to avoid oversweeping the preselector.

² More detailed specifications are given in the HP 70900B Installation and Verification manual.

³ See HP 71209A microwave spectrum analyzer specifications.

Compatibility, HP 70907 external mixer interface module

Model	S/N	Compatibility kit
HP 70907A	all	HP 70907A-K74 upgrade kit required ³
HP 70907B	all	Fully compatible provided HP 70900A/B LO meets the following requirements:
	<i>Firmware date code (YYMMDD)</i>	<i>LO upgrade kit required</i>
	850730	HP 70907B-098
	860203	(RAM/ROM + CPU)
	861015	HP 70907B-099
	870501	(RAM/ROM only)
	880314	
	880901	
	890606	Fully compatible

Ordering Information

HP 70907B external mixer interface module

Option 098 CPU and RAM/ROM upgrade

Option 099 RAM/ROM upgrade

Option 910 extra user manual

Option 915 service manual set

Option W30 two additional years of return-to-HP warranty (3 years total)

Computers and Software

Visual Engineering Environment

HP VEE

Computers
and Software

*Cut test development time
by 20% to 80%*

*Modify programs quickly and
reduce time to market*

*Build systems quickly
and intuitively*

*Leverage existing measurement
programs*

Collect and analyze data quickly

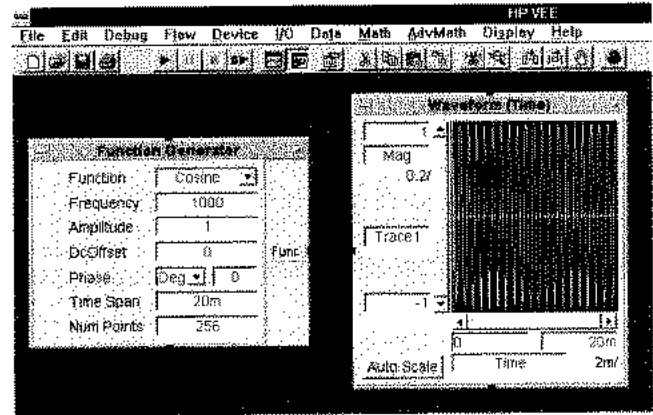

HP VEE increases your productivity

HP VEE is a powerful visual programming language that can be used with MMS. To develop programs in HP VEE, you connect graphical "objects" instead of writing lines of code. These programs resemble easy-to-understand block diagrams with lines.

HP VEE is designed to increase your productivity. One HP VEE object accomplishes an entire series of steps in a typical activity, while still allowing low level "peeks and pokes."

As a full language, HP VEE provides I/O and networking capabilities that iconic GUI (graphical user interface) builders can't handle. It also develops program logic flow that iconic C-code generators don't have.

HP VEE is a better software citizen

HP VEE allows you to leverage your current programming software, such as C/C++, BASIC, PASCAL, and FORTRAN, as well as popular database, word processing, and spreadsheet programs, such as MS Word or Excel.

If your main program is in C/C++, you can call HP VEE programs that would be difficult to write in C/C++ (such as instrument tie-ins), or you can create your main program in HP VEE and call C/C++ programs.

You will like the short learning curve of HP VEE. The language is easy to understand and maintain, so cross-training is enhanced and maintenance efforts are reduced.

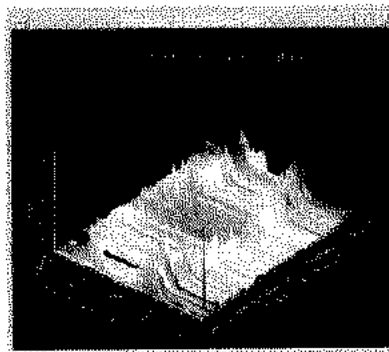

What's new in HP VEE 3.2

HP VEE is more open. It now supports Windows 95 and Windows NT, as well as Windows 3.1, HP-UX series 300 and Solaris platforms. It features easy-to-use VXI plug & play driver support for all Windows and HP-UX series 700 platforms to assure your productivity in multi-vendor environments. HP VEE also offers optional unlimited run time. And you can use HP VEE as either a client or a server.

HP VEE 3.2 now works even better on PC plug-in cards. Data Translation's Visual Programming Interface provides menu picks in HP VEE for seamless PC plug-in data acquisition to over 50 cards. Meilhaus Electronic's data acquisition boards, serial interface boards, and intelligent sensor modules deliver comprehensive PC data acquisition solutions through HP VEE.

You can now export HP VEE data to PV-WAVE, and use this powerful graphics analysis package to display HP VEE data files. Also, you can easily create and print key program parameters, including the information that is especially important for maintaining ISO 9000 documentation. With HP VEE, you can print complete transaction details, not just summaries.

Computers and Software

Visual Engineering Environment

HP VEE

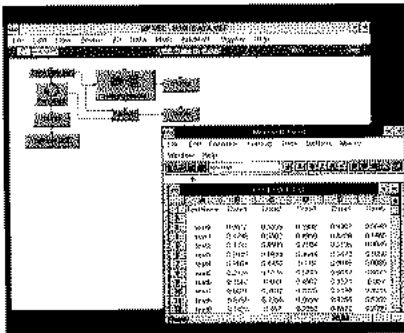

Porting across platforms

HP VEE provides forward compatibility across operating systems to assure maximum productivity among engineers, departments, and companies. These platforms include Windows 3.1, Windows 95, and Windows NT; HP-UX series 700 and series 300; and Solaris.

You can leverage other test programs for use within HP VEE. You can use popular textual languages such as C/C++, Visual Basic, HP BASIC, and FORTRAN. Use standard ties to languages such as Dynamic Link Libraries (DLLs) or Dynamic Data Exchange (DDE) in MS Windows, and Shared Libraries or Named Pipes in UNIX. HP VEE's capabilities can be extended to suit your own application by using off-the-shelf libraries in other languages, as well. You can launch virtually any application available on your operating system and share test data with applications such as spreadsheets and databases.

Support for open, standard computer systems

HP VEE supports the most popular computer platforms including external and HP VXI embedded PCs running MS Windows 3.1, Windows 95, and Windows NT. It also supports external and VXI embedded HP Workstations running HP-UX, and external Sun workstations running Solaris. Interface options include GPIB, VXI, Serial, GPIO, PC Plug-in, and LAN-GPIB.

Free start-up support

Hewlett-Packard's world-class support starts when you register your new HP VEE. At that time you'll receive, at no charge, access to

- HP VEE WEB site/BBS
- HP VEE Internet Users Group
- HP VEE Monthly Newsletter
- HP's 24 hour faxback service
- Other HP Support and Services

In addition to free factory support, HP also offers a complete range of support services to give you access to the latest and most complete world-wide technical support available.

HP training

Learn quickly at your own pace with on-line documentation, HP VEE manuals, or the Prentice-Hall books. All provide practical examples to get you up-and-running quickly. In addition, you can get classroom instruction at an HP VEE customer training center. To register, contact your nearest Hewlett-Packard sales office or call 1-800-HP CLASS in the U.S.

Ordering Information

HP VEE for Windows

HP E2120E HP VEE 4.0 for Windows 95 and Windows NT. (Includes the latest full development software on CD-ROM. English manuals and book, quantity discounts available.)

Opt AGE upgrade/crossgrade version

Opt AA8 additional 3.5 inch floppies

Opt RN1 run time version (one copy); CD-ROM and floppies, English only

Opt RUN run time version (unlimited copies); includes CD-ROM and floppies, English only

Opt 1AK license-to-use only; no manuals or media

Opt AB(x) localization options: ABD German, ABE Spanish, ABF French, ABJ Japanese, ABZ Italian, AB0 Taiwanese

Opt VIS graphics analysis package, PV-WAVE from Visual Numerics

HP E2120C HP VEE 3.1 for Windows 3.1 (Includes full development software on 3.5 inch disks, English manuals, and book)

Opt AGE upgrade/crossgrade version)

Opt RN1 run time version (one copy); CD-ROM and floppies, English only

Opt RUN run time version (unlimited copies); includes floppies, English only

Opt 1AK license-to-use only; no manuals or media

Opt AB(x) localization options: ABD German, ABE Spanish, ABF French, ABJ Japanese, ABZ Italian, AB0 Taiwanese

Controller requirements

HP E2120C Intel 486/33 with Intel 387 coprocessor.

HP E2120D Intel 486/90 or 90 MHz Pentium (486/33 minimum) with Intel 387 coprocessor

Note: HP VEE for Windows is supported on the HP RADEPC7B VXI embedded controller.

Graphics requirements

HP VEE requires a minimum of a 640x480 VGA display system. A 1024x768 SVGA display is highly recommended, particularly for development systems.

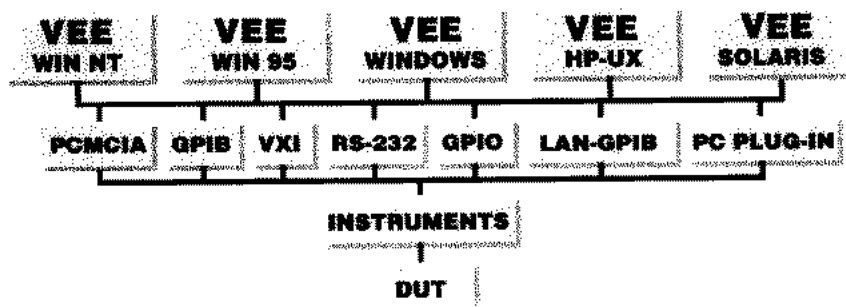

Computers and Software

Visual Engineering Environment

HP VEE

Operating system requirements

MS-DOS version 5.0 or later and MS Windows 3.1. For HP E2120D and 82345C, MS Windows 95 or Windows NT 3.51 is required.

Memory requirements

Windows 3.1 and Windows 95: 16 MB (8 MB min.); Windows NT: 24 MB

Hard disk requirements

25 MB of available disk space

I/O interfaces supported

HP E1483A/E1383A VXLink interface; HP 82340B HP-IB interface; HP 82341C HP-IB interface; HP 82335B HP-IB interface; National Instruments AT-GPIB,

MC-GPIB, GPIB-PCII/PIA, and PC cards; Intel iGPIB/PCMCIA interface; serial interface ports

Recommended peripherals

HP LaserJet, HP DeskJet, and HP PaintJet printers are supported as well as Postscript printers. Windows plotters are also supported.

HP VEE for HP-UX Systems

HP E2111E HP VEE 4.0 for series 700 / HP-UX 9.0 & 10.0. (Includes latest full development software on CD-ROM, English manuals and book, quantity discounts available.)

Opt AGE upgrade from other vendor or old version

Opt AAH additional DAT tape

Opt RUN run time version (unlimited copies); includes CD-ROM and DAT tape, English only

Opt RN1 run time version (one copy); includes CD-ROM and DAT tape, English only

Opt IAK license-to-use only; no manuals or media

Opt AB(x) localization options: ABD German, ABF French, ABJ Japanese, ABZ Italian

Opt VIS graphics analysis package, PV.WAVE from Visual Numerics

HP E2110C HP VEE 3.1 for series 300 and 400/HP-UX 9.0. (Includes full development software on DAT tape,

CD-ROM, and 1/4-inch cartridge, English manuals, and book.)

Opt IAK license-to-use only; no manuals or media

Opt RUN run time version (unlimited copies); includes DAT tape, English only

Opt RN1 run time version (one copy); includes DAT tape, English only

Opt AB(x) localization options: ABD German, ABF French, ABJ Japanese, ABZ Italian

Controller requirements

HP E2110D supports all models of HP series 300 HP-UX workstations and series 400 HP-UX workstations with DIO backplanes. HP E2111D supports HP series 700 HP-UX workstations that include an EISA port and V743 VXI embedded controller.

Graphics requirements

HP VEE runs on color or gray-scale display systems. Six-plane systems or greater are recommended. A variety of these systems are available with

VGA, 1024x768 and 1280x1024 resolution. Both 17-inch and 20-inch monitors are available.

Operating system requirements

HP-UX version 9.0 or greater. X Windows version 11.4 must be installed and running.

Note: X Windows is included in the HP-UX product.

Memory requirements

Minimum required RAM is 24 MB for HP series 300 and 32 MB for HP series 700. Recommended RAM is 32 MB for HP series 300 and 64 MB for HP series 700.

Hard disk requirements

45 MB disk space for HP series 300 and 55 MB for HP series 700. For a full HP-UX system, a 540 MB hard disk is recommended.

Recommended peripherals

HP LaserJet with minimum 2 MB RAM or HP PaintJet printers are recommended for screen printouts.

HP VEE for Solaris

HP E2112D HP VEE 3.2 for Solaris. (Includes full development software on CD-ROM, English manuals, and book.)

Opt IAK license to use only; no manuals or media

Opt AGE upgrade from other vendor or older version

Opt VIS Graphics Toolkit (PV-WAVE) from Visual Numerics

HP E2112C HP VEE 2.1 for Sun operating system. (Includes full development software on CD-ROM, English manuals, and book.)

Opt IAK delete media and manuals

Opt AGE current revision

Controller requirements

Sun SPARCStations® meeting the operating system and windowing system interface requirements listed below.

Graphics requirements

Any display supported by Open Windows 3.4 or later. Color is highly recommended.

Operating system

Solaris 2.4

Memory requirements

A minimum of 24 MB is required;

32 MB are recommended.

Hard disk requirements

45 MB of hard disk space are required.

I/O interfaces supported

IEEE-488.2 (HP-IB/GPIB),

IOtech, Inc. SB488™ SBus IEEE 488.2 Controller-Driver Rev 1.5 (1), IOtech, SCSI488/S™ SCSI to IEEE 488.2 Controller-Driver Rev 1.4, National Instruments NI-488.2™ SCSI to IEEE 488.2 Controller-Driver Rev 2.2 (1), Serial: Internal RS-232 serial ports A and B.

Note: Some newer SPARCStations may not be compatible with some SBus I/O interfaces. Please consult I/O vendor (IOtech or National Instruments) for the latest detailed information.

Recommended peripherals

HP LaserJet printers with Postscript only; Postscript printers; HP-GL plotters

HP VEE site licenses

HP E2117E HP VEE 4.0 Site License. (Includes license for 50 full development seats plus license for unlimited number of run-time copies, and 6 physical copies of the entire product: (1) E2110C, (1) E2111D, (1) E2112D and (3) E2120D. One year of phone support and software update service included.)

Opt AGE quantity of upgrade/credit for previous purchases (up to half of total seats)

Opt AB(x) localization options: ABD German, ABF French, ABJ Japanese, ABZ Italian

Note: Option VIS Graphics Analysis Package (PV.WAVE) from Visual Numerics is available with E2111E, E2112D and E2120E. It interprets HP VEE's TO FILE data container and enhances its rich data types by displaying 2D, 3D and 4D tables, graphs, plots, surfaces, and projections for visual analysis and presentation.

Accessories Round Out Your Systems

System Accessories

Accessories for the Modular Measurement System

Mainframe cosmetic panel

Used to occupy empty module slots in a mainframe. Mainframe control panels improve appearance only and are not needed for operation.
Part no. 5062-6448 one slot

Memory card

HP 85700A (part no. 0950-1964)
32K RAM blank memory card
HP 85702A (part no. 82215-80001)
128K RAM blank memory card

Hardkey panels for the HP 70004A display

Part no. 70004-60045 blank hardkey panel
Part no. 70820-60086 microwave transition analyzer panel
Part no. 70900-60208 spectrum analyzer panel
Part no. 70950-60033 optical spectrum analyzer panel

HIL keyboard

Part no. 46021A keyboard for the HP 70004A display
Part no. 46020-60001 keyboard cable

External RGB monitors

For the HP 70004A and 70205A displays (these will sync from 15 to 25 kHz horizontal sweep rates)
For information, call your Hewlett-Packard sales representative.

Multisynch color monitors

Use any multisynch monitor designed for PCs, available from PC dealerships. The HP 70004A synch rate falls between two standard PC synch rates and so requires a multisynch monitor.

For information, call your Hewlett-Packard sales representative.

400 Hz power line frequency option

Part no. 70001-60066 isolation-transformer assembly for the HP 70001A mainframe
(The HP 70004A display operates from 50 to 400 Hz standard.)

Rack mount flange kits and slide kits

For the kits listed below, the rack height required for the HP 70001A mainframe is 177 mm (7 inch); for the HP 70004A display, 222 mm (8.75 inch).

Rack mount flange kit

To mount instrument without handles, use
Part no. 5062-3978 for the HP 70001A mainframe;
Part no. 5062-3979 for the HP 70004A display.

Rack mount flange kit

To mount instrument with handles, use
Part no. 5062-4072 for the HP 70001A mainframe or the HP 70206A display;
Part no. 5062-4073 for the HP 70004A display.

Rack slide kits

Part no. 5062-0781 for the HP 70001A mainframe
Part no. 5062-7086 for the HP 70004A display

HP 70310A power pack

Part no. 70310-60016 power pack
external, attaches to the HP 70001A backplane for the HP 70310A ovenized oscillator (except module Option 002)

Tools

SMB cable puller, part no. 5021-6773
5/16 inch wrench for SMA cables, part no. 8720-0015
Module installation tool, part no. 8710-1307
8 mm hex-ball driver

System Accessories

Cables

HP-MSIB cables

Required to connect the HP 70004A and the HP 70206A displays to the HP 700001A mainframe, and to connect mainframes. Two HP 70800B HP-MSIB cables are included in standard systems as needed. For cables of other lengths up to 1.0 km, please contact your local sales representative.

- HP 70800A HP-MSIB cable (0.5 m)
- HP 70800B HP-MSIB cable (1 m)
- HP 70800C HP-MSIB cable (2 m)
- HP 70800D HP-MSIB cable (6 m)
- HP 70800E HP-MSIB cable (30 m)

Accessory cable kit

Accessory cable kit 71000-60003 includes the following:

- 12 SMB cables of assorted lengths (2 @ 190 mm, 2 @ 240 mm, 3 @ 290 mm, 3 @ 365 mm, 2 @ 390 mm)
- 1 flexible 520 mm SMA cable, part no. 5061-9038
- 2 SMB tees (mlin), part no. I250-1391
- 1 8-mm hex ball driver, part no. 8710-1307
- 1 5/16 inch wrench, part no. 8720-0015
- 1 cable puller, part no. 5021-6773

LO cables

Used to route the local oscillator signal between modules. Available in semi-rigid and flexible versions. Module-to-module semi-rigid LO cables are designed to accommodate three possible types of module orientation. Right out, left-in cables are used when, looking at the mainframe from the rear, the LO output post is on a module to the right of the LO input port. Left-out, right-in cables are used when the output port is to the left of the input port. Vertical, mainframe-to-mainframe cables are used to connect LO ports located at the same horizontal position in adjacent, stacked mainframes. Flexible LO cables are available in two lengths and can accommodate any orientation if the length is sufficient.

Right-out, left-in semi-rigid LO cable (SMA)

- Part no. 5021-5448 1-slot module spacing
- Part no. 5021-5449 2-slot module spacing
- Part no. 5021-5450 3-slot module spacing
- Part no. 5021-5451 4-slot module spacing
- Part no. 5021-5452 5-slot module spacing
- Part no. 5021-5453 6-slot module spacing
- Part no. 5021-5454 7-slot module spacing

Left-out, right-in semi-rigid LO cable (SMA)

- Part no. 5021-5491 1-slot module spacing
- Part no. 5021-5492 2-slot module spacing
- Part no. 5021-5493 3-slot module spacing
- Part no. 5021-5494 4-slot module spacing
- Part no. 5021-5495 5-slot module spacing
- Part no. 5021-5496 6-slot module spacing
- Part no. 5021-5497 7-slot module spacing

Vertical, mainframe-to-mainframe semi-rigid LO cable (SMA)

- Part no. 5021-6311

Flexible LO cables (SMA)

- Part no. 5061-9038 within mainframe, 520 mm
- Part no. 5061-9039 mainframe-to-mainframe, 745 mm

Semi-rigid cables for preselector modules

- Part no. 5021-7402 cable HP 70600A to HP 70905A
- Part no. 5021-7403 cable HP 70600A to HP 70905B

System cables (SMB, flexible)

Used to route all rear panel signals (except LO signals)—such as IF, video, and 300 MHz—between modules. The cables used are identical for each type of signal and can be used interchangeably.

	SIGS	E	CSL
Part no. 8120-5015 1-slot module spacing (100 mm)	✓		✗
Part no. 8120-5016 2-slot module spacing (160 mm)	✓		✓
Part no. 8120-5017 3-slot module spacing (205 mm)	✓		✓
Part no. 8120-5020 4-slot module spacing (260 mm)	✓		✓
Part no. 8120-5021 5-slot module spacing (310 mm)	✓		✓
Part no. 8120-5022 6-slot module spacing (365 mm)	✓		✓
Part no. 8120-5023 7-slot module spacing (410 mm)	✓		✓

Cables greater than 7-slot module spacing

Part no. 8120-5024 445 mm	✓	✓
Part no. 8120-5025 490 mm	✓	✓
Part no. 8120-5026 620 mm	✓	✓
Part no. 8120-5351 725 mm	✓	✗
Part no. 8120-5028 975 mm	✓	✗
Part no. 8120-5029 1080 mm	✓	✓

Preamplifier cables

Semi-rigid front panel cables connecting the modular preamplifiers to various RF sections. Looking at the front of the mainframe, the preamplifier appears to the right of the RF section.

	HP 70620B	HP 70621A
HP 70904A	5022-0003	5021-7402
HP 70905A	5022-0003	5021-7402
HP 70905B	5021-7401	5021-7403
HP 70906A	5021-9931	
HP 70908A	5021-9952	5021-8636
HP 70909A	5022-0137	5022-2825
HP 70910A	5022-0137	
HP 70600A	5022-0003	5021-7402
	5021-7401*	

*Choose this cable when the preselector is placed before the preamplifier in the RF path.

MSIB Y-Cable

One MSIB Y-cable is supplied with the HP 70207B PC Display for MMS. The MSIB Y-cable extension adapter is available for mechanical rigidity of MSIB cable extensions.

- HP 70207-60003 MSIB Y-cable (2 m)
- HP 70207-20003 MSIB Y-cable extension adapter

Customer Support

NOTE: The following information applies only to MMS products manufactured by Hewlett-Packard Company.

I. Service and support

Flexible service and support alternatives

The modular measurement system has many system support alternatives. Most HP 70000 systems offer additional tools for calibration and repair of modules and instruments. Some of these tools are system performance test software, diagnostic routines, and service software and documentation.

Choose from several different support alternatives for servicing HP 70000 modular measurement systems. The choices vary from sparing modules and having little or no down time, to using the documentation and software available for customer in-house repair and calibration, to returning an instrument to HP. HP has more than 40 Customer Service Centers worldwide and two part centers.

The design of the MMS gives you the ability to interchange modules and retain system calibration without recalibration adjustments. Retention of system calibration means you can add new modules, swap modules for repair, or modify capabilities. Simply swap modules and run a one-button internal calibration routine.

HP provides for return-to-factory repair and calibration of system configurations that cannot be calibrated in the field. In particular, the HP 71400C and 71401C lightwave signal analyzers must have the HP 70810A or the 70810B and the HP 70908A or 70904A modules returned to the factory for calibration and characterization of the RF path.

High uptime with module sparing

If your situation demands that you operate your modular system 100% of the time, HP can provide the best support alternatives available today. By choosing to keep spare modules on hand, you can have an operating, calibrated system with no down time. Spare modules can be calibrated in the system of choice ahead of time to insure system calibration integrity.

Spare modules can be stocked based on the mean time between failure (MTBF) of individual modules—not necessarily whole instruments. In a spectrum analyzer, for example, many modules have MTBFs of greater than 15,000 hours.

Diagnostics available

A broken module can be easily isolated and replaced via the self-diagnostic error reporting capability of the modular measurement system. Access to this reporting capability is available through any display by using the REPORT ERRORS softkey.

Many instruments have built-in or downloadable diagnostic routines. These routines analyze module fault detectors for inoperable system functions. Every HP modular spectrum analyzer is shipped with a downloadable diagnostic program that can be executed easily by a simple keystroke.

II. Calibration

Recommended calibration cycle

Many of the HP 70000 modular instruments now recommend a three year calibration cycle. Refer to the individual instrument for recommended calibration cycle.

MIL-standard 45662A direct from the factory

HP offers an option for certified calibration from the factory. When you order a standard MMS spectrum analyzer or HP 71600 series BERT with Option 1BN, you receive a certificate of calibration in full compliance with MIL-STD 45662A that is good for a period of two years. Option 1BP is also available if you require documented data to support the system calibration.

Single and multi-module instrument calibration

Single-module instruments and complete multi-module instruments must be calibrated as a complete unit¹. Single module instruments, such as the HP 70100A power meter, have their own set of specifications on which to base the calibration. A single module instrument either has manual performance test procedure or it has performance test software included with Option 915.

Modules contained in a multi-module instrument, such as an IF section in a spectrum analyzer, cannot be calibrated independent of a complete HP 70000 spectrum analyzer system configuration. A module from one calibrated HP 70000 spectrum analyzer system (system A) can be transferred and reconfigured in another calibrated HP 70000 spectrum analyzer system (system B). System B will remain calibrated, provided that the internal self-correction routine (CAL ALL) has been performed after the module is transferred. This takes about two to three minutes to run.

¹ The HP 71600 series BERT consists of up to three modules. Each module has its own set of specifications and can be calibrated individually.

Customer Support

III. Module and system test process for spectrum analyzers

System diagnostics

System diagnostics software is a standard software package that is downloaded into, and included with, every HP 70000 series spectrum analyzer.

This program consists of troubleshooting routines that detect a suspected defective module. The most recent version requires approximately 12 KB of RAM in the HP 70900A/B LO module and takes approximately 10 minutes to run. First pass testing is performed in uncorrected mode. If no problems are detected, CAL ALL is invoked and the test is run again in corrected mode.

An HP 9000 series 200 or 300 computer is required to download the system diagnostic software. Once downloaded, the computer is not required to run the diagnostic program.

Module repair

To ensure module interchangeability, various test processes in the standard module documentation must be followed after module repair. These processes include module adjustment, module verification, and system verification as given below.

Module adjustment

After a module has been repaired, it must receive all adjustments listed in the Adjustment Procedures section or specific repair-related adjustments called out in the Troubleshooting section of the module's service manual. (Adjustments are never made at the system level.)

Modularity

Whenever a module has been repaired and adjusted, it must pass all Module Verification final tests. Additional tests, listed under Related Verification Tests in the Troubleshooting section of the module's service manual, must also be performed. These tests ensure modularity in any HP 70000 system.

System verification

After a module has been repaired and has passed all required adjustment and verification tests, the module must be configured into, and its performance verified in, a calibrated spectrum analyzer system using at least the Limited CAL mode of the HP 11990A system performance tests.

The HP 70000 modular measurement system was designed to provide you with the flexibility to interchange modules and retain system calibration without recalibration adjustments. This means you can transfer a module from one calibrated system to another.

IV. Test software descriptions for spectrum analyzers

There are three levels of software available for the MMS products. They are individual module verification, HP 70900B system operation verification, and HP 11990A system performance tests.

Module verification

Module verification test software is included with Option 915. It encompasses the lowest level of the MMS module test process. This software includes specific adjustment procedures and verification tests, each of which is designed for individual modules. Module verification tests exist to ensure that a module will perform to specifications within HP 70000 systems. However, the test does NOT assure that an individual module is calibrated. (The terms "calibrated" and "calibration" are defined here as verification of specified performance.) A module that is an integral part of an MMS spectrum analyzer, for example, does not have its own documented specifications. Only the complete spectrum analyzer system, which has documented specifications, can be calibrated.

System operation verification

System operation verification software is a standard software package that is included with every HP 70000 spectrum analyzer. This package consists of approximately 30% of the HP 11990A system performance test software. The software is used to verify specified system performance of the HP 70000 spectrum analyzer to approximately an 80% confidence level. The intent is NOT for complete verification of specified system performance. Recommended test equipment for system operation verification test software is denoted with ² in Table 1 on the following page.

Additional instrument drivers that provide test equipment substitution are included with this software package. For information regarding test equipment substitution, refer to the verification section.

HP 11990A system performance test software

HP 11990A system performance test software verifies the performance to specifications of HP 70000 spectrum analyzers. The software is used at HP Customer Service Centers to perform Commercial and Military Standard 45662A calibrations.

The HP 11990A ensures traceability of those specifications to the U.S. National Institute of Standards and Technology (NIST) or equivalent government standards agencies elsewhere. The HP 11990A system performance test software produces documented data to support calibration.

No adjustments are performed while using this software. HP 11990A Option 033 is available to verify specified performance of the HP 70300A and 70301A tracking generators with an HP 70000 spectrum analyzer.

The HP 11990A system performance test software prints out test data and includes all serial numbers of the modules in the new system.

Customer Support

HP 11990A system performance test software *continued*

The HP 11990A system performance test software provides complete measurement uncertainty on the test printout. The uncertainty for each measurement is calculated at the time of the measurement, and reflects the choice of test equipment and the length of time since the test equipment was last calibrated.

This software must be ordered as an individual product. If you wish to order it, the HP 11990A user interface Option 001 must be ordered along with the appropriate system option (Option 210 for an HP 71210C/P, for example).

Recommended test equipment for HP 11990A system performance test software is denoted with ²; additional recommended test equipment for the HP 11990A is denoted with ³ in Table 1.

Included with this software package are additional instrument drivers that provide for some test equipment substitution. For information regarding test equipment substitution, refer to the optional system software package for the HP 11990A system performance test software.

V. Warranty

The HP 70000 instruments come with a standard 1 year warranty. This warranty covers all charges for parts and labor. There is also an Option W30 available that provides you with an additional 2 years of return repair service coverage.

VI. Support life

The support life for all MMS products is a minimum of 5 years and may extend 10 years beyond obsolescence. This means that there will be hardware, firmware, software, and documentation to support the HP 70000 spectrum analyzers for a period of at least 5 years after the module has been discontinued.

If you wish to order replacement parts and software for HP 70000 series products, please contact the HP Support Materials Organization at 1-800-227-8164 (U.S. only).

For HOTLINES in the U.S., dial 1-916-785-8HOT.

Ordering Information

- HP 11990A** spectrum analyzer system performance test software
- Option 001** performance test user interface
 - Option 033** tracking generator test software
 - Option 100** performance tests for the HP 71100A/C/P
 - Option 200** performance tests for the HP 71200A/C/P
 - Option 209** performance test for the HP 71209A/P and partial test for the HP 71910A/P
 - Option 210** performance tests for the HP 71210A/C/P
 - Option 300** performance tests for the HP 70907A/B/71300A

VII. Equipment Requirements

Table 1 lists the test equipment necessary to support all HP 70000 spectrum analyzers and the power meter modules. It includes most of the standard HP RF and microwave test instrumentation.

Table 1. Test equipment requirements to support HP 70000 modules¹

- ¹ Lightwave signal analyzers and BERTs are return-to-HP repair.
- ² Recommended test equipment for system operation verification test software and HP 11990A system performance test software
- ³ Additional recommended test equipment for the HP 11990A

Instruments (HP model number)	Accessories (HP model number)
Series 200/300 controller ²	8721A directional bridge ²
3335A frequency synthesizer ²	10008B 1:1 probe
3456A digital voltmeter ²	10100C 50 W feedthrough
3478A digital multimeter ²	0955-0204 isolator 3.0-6.6 GHz
5343A microwave counter ²	8493C #010 10 dB pad
8340A/B synthesized sweeper ²	8493C #006 6 dB pad
8566B spectrum analyzer ³	1667B power splitter ²
71200C Option 003 spectrum analyzer	11534A RF mixer
8902A measurement receiver ²	85027B directional bridge
11722A sensor module ²	85027-60002 connector savers
8662A/3A synthesizer ²	85027-60004 open/short
8757A network analyzer	909D Option 040 50 W load
5316B universal counter ³	101664E detectors (2)
8970B noise figure meter	346C noise source
8116A Option 010 function generator ²	8482A power sensor ²
436A power meter ²	8485A power sensor ²
1741A oscilloscope	11990A K12 12 MHz LP filter ³
8447A RF amplifier	71000-60002 MMS service kit
70001A mainframe (modified,opt'l)	70900-60102 LO service kit
8496G Option 001 10 dB step attn	70206-60058 display service kit
11713A attenuator driver	70902A K01 21.4 MHz N filter
11970K external mixer ²	70900A K01 sniffer loop
ZFSC-2-5 MCL hybrid combiner ²	70900A K02 resistive divider
K752C directional coupler ²	70900A K03 300 MHz upconverter
Additional cables and adapters	0955-0306 50 MHz LP filter ³
For HP 70100A power meter add:	
5328A/Option 031 (10 Hz-50 MHz frequency counter, 1 Hz res)	
432A power meter	
478A/H76 thermistor mount	
11683A range calibrator	

Customer Support

VIII. Documentation

A full series of documentation and software is available for the HP 70000 systems. If you would like service support documentation for your HP 70000 system, include Option 915 with your order (if available). Option 915 may include software that is necessary for individual module support. Option 910 provides an additional set of user manuals for your modular measurement system.

Replacement documentation can be ordered from HP DIRECT at 1-800-538-8787 (U.S. only). The following list includes the documentation that are available through HP DIRECT.

Model number	Part number	Description	Model number	Part number	Description
11990A	11990-90051	User's Guide	70422A	70422-90002	User's Guide
70001A	70001-90021	Installation/Verification Guide		70422-90003	Service Guide
	70001-90060	Service Guide		70422-90004	Component Level Information
	70001-90061	Component Level Information	70427A	70427-90059	Operation/User's Guide
70004A	70004-90005	Installation/Verification Guide		70427-90060	Service Guide
	70004-90031	Operation/User's Guide	70427A	70427-90061	Component Level Information
	70004-90046	Service Guide	70590A	70590-90023	Installation/Verification Guide
	70004-90047	Component Level Information	Opt. H69/H72		
70100A	70100-90001	Installation/Verification Guide	70590A	70590-90004	Installation/Verification Guide
	70100-90002	Service Guide	Opt. H05		
	70100-90012	Manual Supplement	70597A	70597-90006	Component Level Information
70110A	70110-90012	Operation/User's Guide	70611A	70611-90011	Operating/Service Manual
	5964-9795E	Technical Specification	70612A	70611-90011	Operating/Service Manual
70120A	70120-90007	Operation/User's Guide	70612C	70611-90011	Operating/Service Manual
70205A/	70206-90022	Installation/Verification Guide	70613A	70611-90011	Operating/Service Manual
70206A	70206-90030	User's Guide	70613C	70611-90011	Operating/Service Manual
	70206-90025	Service Guide	70620B	70620-90036	Installation/Verification Guide
	70206-90027	Component Level Information		70620-90024	Service Guide
70207A	70207-90001	User's Guide		70620-90026	Component Level Information
70207B	70207-90008	User's Guide	70621A	70620-90036	Installation/Verification Guide
70300A	70300-90107	Installation/Verification Guide		70620-90024	Service Guide
	5958-7011	Operation/User's Guide		70620-90026	Component Level Information
	70300-90090	Service Guide	70700A	70700-90001	Installation/Verification Guide
	70300-90092	Component Level Information		70700-90047	Manual Supplement
70301A	70301-90039	Installation/Verification Guide		70700-90003	Operation/User's Guide
	5958-7011	Operation/User's Guide		70700-90021	Programming Manual
	70301-90033	Service Guide		70700-90005	Service Guide
	70301-90014	Component Level Information	70703A	70703-90028	User's Guide
70310A	70310-90059	Installation/Verification Guide		70703-90029	Programming Manual
	70310-90061	Service Guide	70810B	70810-90067	Operation/User's Guide
	70310-90075	Component Level Information		5954-9137	Application Note
70330A	70330-90011	Installation/Verification Guide	70820A	70820-90047	Quick Start Guide
	70330-90001	Service Guide		70820-90070	Installation/Verification Guide
70332A	70332-90011	Installation/Verification Guide		70820-90049	User's Guide
	70332-90001	Service Guide		70820-90051	Reference Guide
70340A	5960-7095	Quick Start Guide		70820-90053	Programming Manual
	5960-7096	Operation/User's Guide		70820-90005	Service Guide
	70340-90007	Service Guide		70820-90016	Component Level Information
	70340-90010	Component Level Information		70820-90033	Tutorial
	5960-7083	Calibration Kit Manual	70874A	70874-90002	Operation/User's Guide
70341A	5960-7095	Quick Start Guide	70875A	70875-90001	Operation/User's Guide
	70341-90003	Installation Guide	70900A	70900-90045	Installation/Verification Guide
	5960-7096	Operation/User's Guide		70900-90212	Manual Supplement
	70341-90002	Service Guide		5958-4233	Operation/User's Guide
	70341-90004	Component Level Information		70900-90141	Manual Supplement
70420A	70420-90004	User's Guide		5958-6467	Programming Manual
	70420-90005	Service Guide		70900-90142	Manual Supplement
	70420-90006	Component Level Information		70900-90116	Service Guide
				70900-90270	Component Level Information

Numerical Index

HP 71608	13	HP 8662A	18, 35
HP 71603B, 71604B	108, 112, 113	HP 8721A	166
HP 71612A series	112, 113	HP 85700A	164
HP 71707A	35, 36	HP 8590	130
HP 71708A	18, 19	HP 89410A	10, 43
HP 71910A/P	37-43	HP 9122C	139
HP 773D, 774D, 775D, 776D, 777D, 778D	166	HP 9153C	139
HP 81600 series	103	HP E4543A	113
HP 8168x	103	HP E4544A	113
HP 82215A	164	HP E5500	18, 35
HP 8340B	12	HP VEE	132, 137, 161-163
HP 83437A	103	HP-MSIB	165
HP 83480A	113	I	
HP 83810B	99	iPanels	130, 131
HP 8480	21, 22	T	
HP 8481	21	TTI Model 890225A	125
HP 84940A	117, 121	TTI Model 9286	127
HP 85024A	166	TTI Model 930219-101	126
HP 85044A	166	TTI Model 9302-M1	126
HP 85044A/B	166	TTI Model 9302-M2	128
HP 85044B	166	TTI Model 9403A	128
HP 8566B	3, 12, 56		

Alphabetical Index

A

accessories	164
accessory cable kit	165
active probe	166
adapter	166
aerospace/defense ATE systems	9
ARGOSystems, Inc.	11
attenuator/switch driver	117-121

B

bit error rate tester (BERT)	112, 113
------------------------------------	----------

C

cables	165
calibration	23, 168
CASS	9
channel measurements	37
chirp and frequency hopping	37
color display	138, 139
compatibility	70, 72-74
component test system	141
computers and software	161-163
Condor Systems, Inc.	91
configuration example	9-12
controller board upgrade kit	69
custom engineering	90, 91, 124, 130, 131
custom microwave switching	133
custom switch matrix	116
custom test system services	132
customer support	167-172

D

diagnostic self test	23
digital multimeter	23, 24
digital persistence display	69
digital radio	37
digital radio analyzer	92
digitizer	26-28
digitizing oscilloscope	29, 30
direction-finding receiver	11
directional bridge	166
documentation	171
downloadable program (DLP)	20, 45, 46, 69
downsized Automatic Test Equipment	5
dual directional couplers	166

E

equipment requirements	170
erbium-doped fiber amplifier	103
external mixer interface module	159, 160
external RGB monitors	164

F

Fast Fourier Transform (FFT)	45
fiber-optic interferometer	99
functional test software	113
fundamentally mixed microwave spectrum analyzer	65-68

G

general accessories	166
gigabit error performance analyzers and pattern generators	112, 113

H

Hamilton Software	130, 131
hardkey panels for the HP 70004 display	164
Hewlett-Packard	124
Hewlett-Packard Channel Partner	132, 133
high impedance probe	166
HIL keyboard	164
Honeywell, Inc.	9
HP 70000 series	44-55
HP 70900A firmware history	72
HP engineering and integration services	124
HP-MSIB cables	165

I

IBASIC	31
I/Q signal identification	37
IF sections	151-153
IFTE	9
instruments	13, 14
integrated family of test equipment	9
interface modules	122, 123
iPanels	130, 131
isolator	166

J

jitter and eye-diagram analyzer	108-111
---------------------------------------	---------

L

lightwave and communications	90-113
lightwave section	97, 98
lightwave signal analyzers	93-96
lightwave signal analyzers & accessories	93
LO cables	165
LO section	39
local oscillator	148-150
Lockheed Martin Information Systems Company	9
LANTIRN	9

Alphabetical Index

M

mainframe cosmetic panel	164
Martin Communications Pty Ltd.	92
mass storage	46
MATE module	145
McDonnell-Douglas	9
memory card	164
microwave downconverter	35, 36
microwave input module	128
microwave interface unit	126
microwave output module	126
microwave source	18, 19
microwave spectrum analyzer	56-64
microwave synthesizer	15, 16
microwave transition analyzer	31-34, 146, 147
millimeter spectrum analysis	87-89
minimum loss pad	166
mixer test system	12
MMS consortium	8
modular measurement system	3
modular measurement system components	129
modular measurement system displays	138
module and system test process for spectrum analyzers	169
multiple- instrument workstations	14
multisynch color monitors	164

N

noise-figure measurement personality	80, 81
Northrop Grumman Corporation	9

O

optical spectrum analyzers	100-107
----------------------------------	---------

P

PC display for MMS	137
phase measurements in multi-channel systems	37
phase noise	18, 35, 127
power meter	20-22
power splitter	166
preamplifiers	75-79
precision frequency reference	143, 144
probe divider	166
pulse shape characterization	37

Q

Q-factor measurements	113
-----------------------------	-----

R

rack mount flange kits	164
rack slide kits	164
radar	37, 45
radio frequency mobile electronics test set	5
RAM/ROM board upgrade kit	69

remote operation software	130, 131
resources and tools	115
RF cable kit	166
RF receiver module	125
RF sections	154-158
RF spectrum analyzer	47-50

S

satellite test system	10
scalar-network-analysis personality	45
SCPI programming	16, 23, 25
service and support	168
signal analyzers	20-43
signal monitoring	37
single-module instruments	14
sources	15, 16, 18, 19
spectrum analyzer systems	44
spectrum analyzers	44-89
spurious tests	46
support life	170
surveillance	37, 46, 56
Symtx	132, 133
system accessories	164-166
system building blocks	134-160
system displays	138-140
system integration	114-133
system mainframe	136

T

TCXO	25
Tern Technology, Inc.	9, 124-129
TEWS.....	9
TISS	9
tools	164
tracking generator systems	82-86
tracking generators	141, 142
transmission/reflection test sets	166

U

ultra-wide bandwidth IF section	39
universal counter	25
upgrade kits	69-74

V

Vector Signal Analyzer	43
Visual Engineering Environment (HP VEE)	137, 161-163
VXIbus	5

W

warranty	170
wide bandwidth RF section	39
wide bandwidth receiver	37-43

X

x-band linear amplifier	128
-------------------------------	-----



modular measurement system

--	--	--	--

**Copyright © 1998
MMS Consortium**

**Data subject to change
All rights reserved
Printed in U.S.A.
5965-2818E**



modular measurement system

MMS